



MS HYDRAULIC

AXIAL PISTON MOTORS AND PUMPS

HEAVY DUTY FIXED DISPLACEMENT

In cooperation with  **HES**
HYDRAULIC ELEMENTS & SYSTEMS

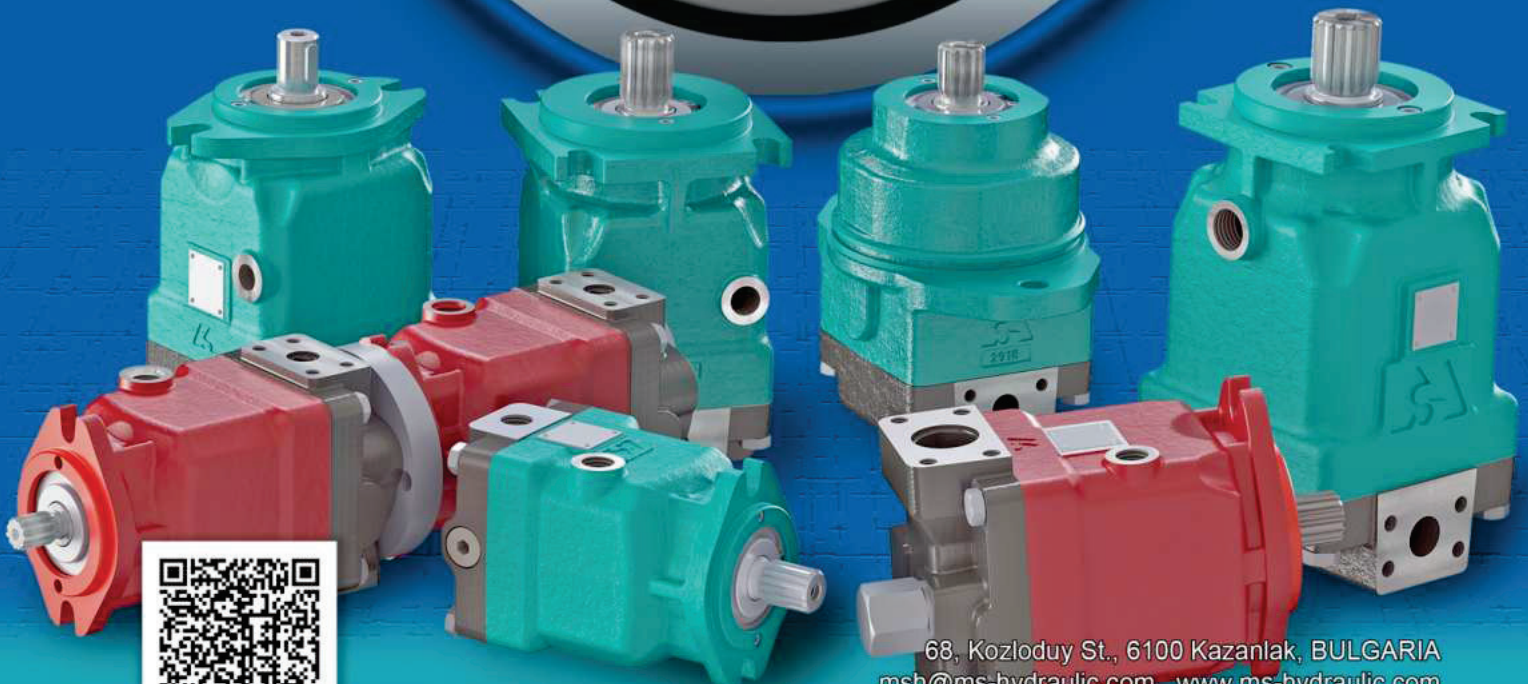

68, Kozloduy St., 6100 Kazanlak, BULGARIA
msh@ms-hydraulic.com www.ms-hydraulic.com
tel.: + 359 431 65167, + 359 431 64271, fax: + 359 431 64114

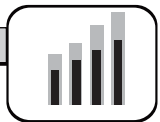

CONTENT

Axial Piston Motors and Pumps

Heavy Duty Fixed Displacement Swash Plate

[Technical Specification Guide.....3](#)

[Hydraulic motor MAP288](#)

[Hydraulic motor MAP6220](#)

[Hydraulic motor MAP10032](#)

[Hydraulic motor MAPW62.....44](#)

[Hydraulic pump PAP28.....52](#)

[Hydraulic pump PAP6262](#)

[Shaft dimensions69](#)

[Valves, Special Features, Application, Installation information, Diagrams and Formulas.....74](#)

Version history

Date	Page	Changed	Ver.
January 2021		Added option flange type 4L into series MAP62 and MAP100, Minor fixes	3.2
January 2020		Added series: PAP28, series MAP50 and MAP62 are combined into MAP62, Minor fixes	3.1
February 2019	38	Added: Note shaft type SP is available only for Pos.1 option flange type 4C	2.1
October 2018		Added series: MAP62 and MAPW62. Added displacements: 52, 58 and 62 PAP. Castings update	2
April 2018		Minor fixes	1.4g
February 2017	4;8;10;11;12;13;14;15;16;18;19;20;23;25;27;29;30;35;39;43;45;50;55;56;60;61;63;64;65;68;69	Additional options: Twin Side option for MAP28 and MAP100; Shaft types DR and DO for MAP50 and PAP50; Improved Bearing option for MAP28; Shaft type CM for MAP28; speed sensor option for MAP28, MAP50, MAP100 and PAP50; addition valves for MAP28; port type 6 for MAP28; port type 9 for MAP28, MAP50 and MAP100. Correction of MAP50 ports. Change of the Specification Data of MAP28, MAP50, MAP100 and PAP50. Minor fixes.	1.4
July 2016		First official edition	1.3

"M+S HYDRAULIC" takes no responsibility for possible errors in catalogues, brochures and other printed material. "M+S HYDRAULIC" reserves the right to alter its products without notice. This also applies to products already on order provided that such alterations can be made without subsequential changes being necessary in specifications already agreed.

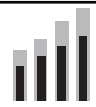

SPECIFICATION DATA MOTORS TYPE MAP

Intermittent values

Continuous values

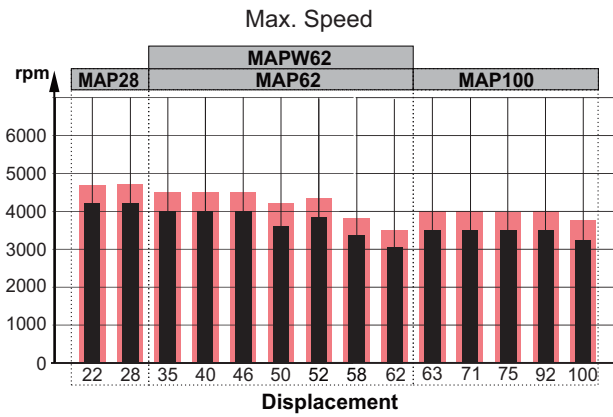
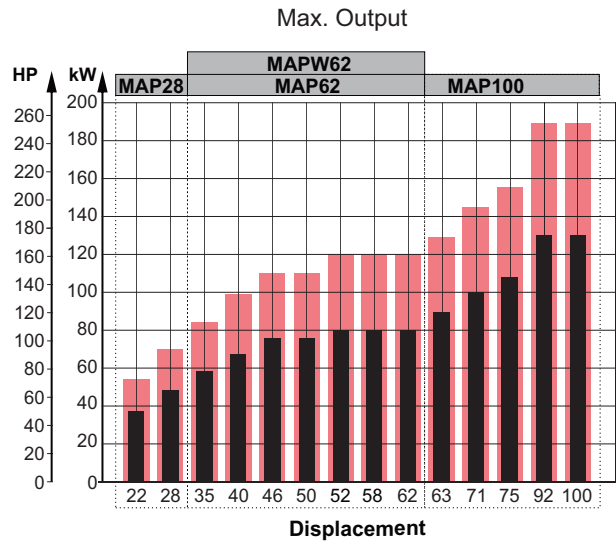
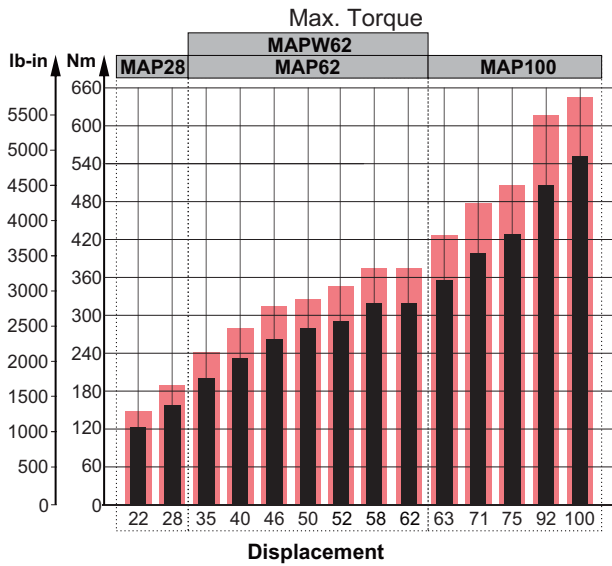

Specification Data Pumps Type PAP

Intermittent values

Continuous values

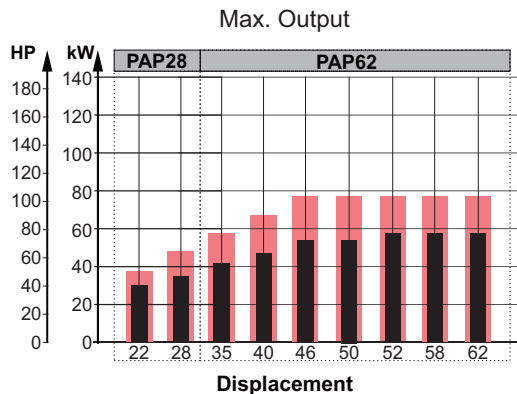
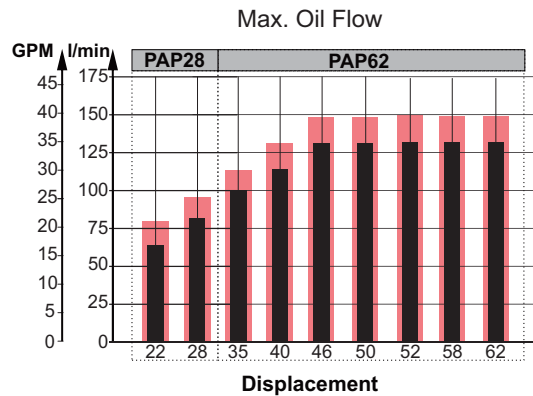
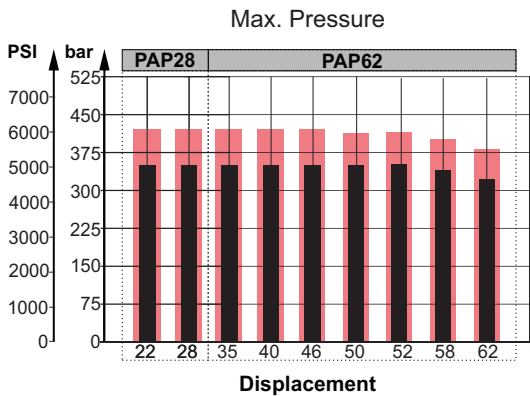

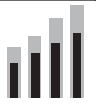

MOTOR DIMENSIONS

The below dimensions are for **comparison only**. The motors can obtain different flanges, shafts and end covers.

MAP28

Flange	D mm[in]
SAE A	82.5 [3.25]
SAE B	101.6 [4]

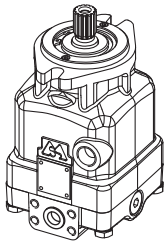
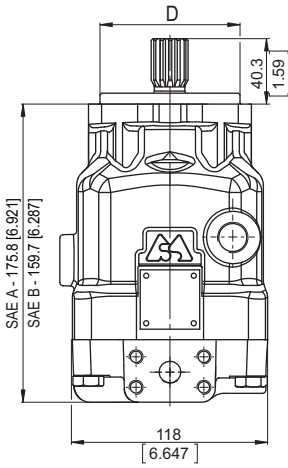

MAP62

Flange	D mm[in]
SAE B	101.6 [4]
ISO 4L	125 [4.92]
SAE 4C	127 [5]

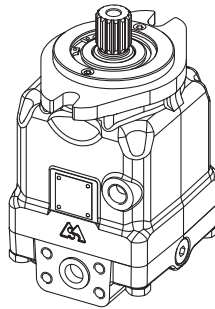
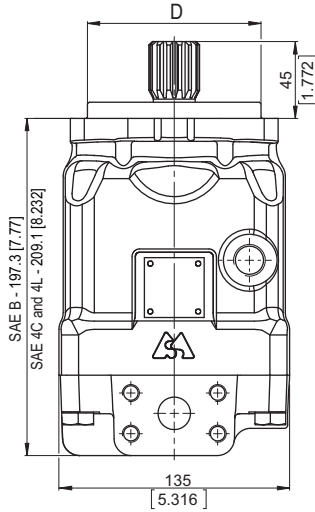

MAP100

Flange	D mm[in]
ISO 4L	125 [4.92]
SAE 4C	127 [5]
ISO 4M	140 [5.51]

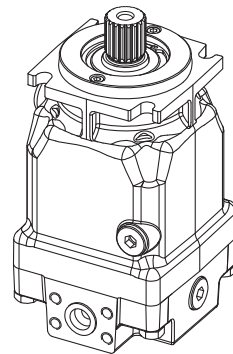
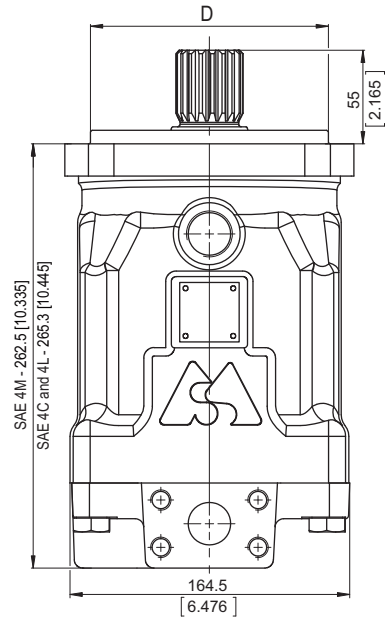

MAPW62

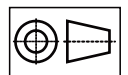
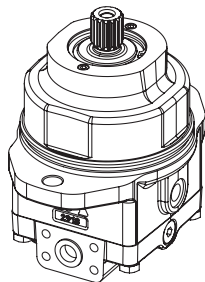
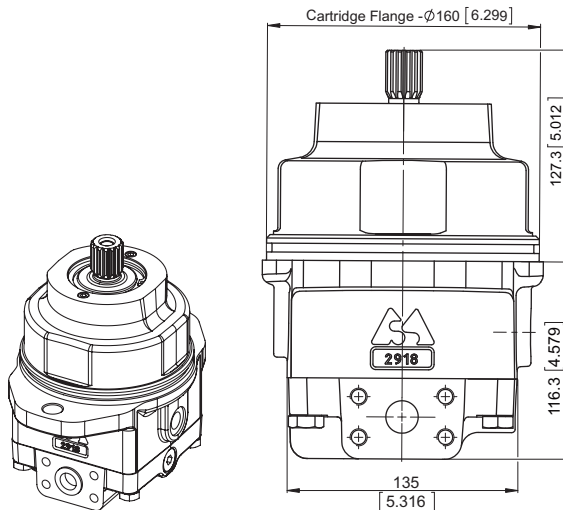

mm [in]

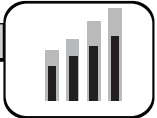

PUMP DIMENSIONS

The below dimensions are for **comparison only**. The motors can obtain different flanges, shafts and end covers.

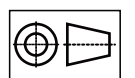
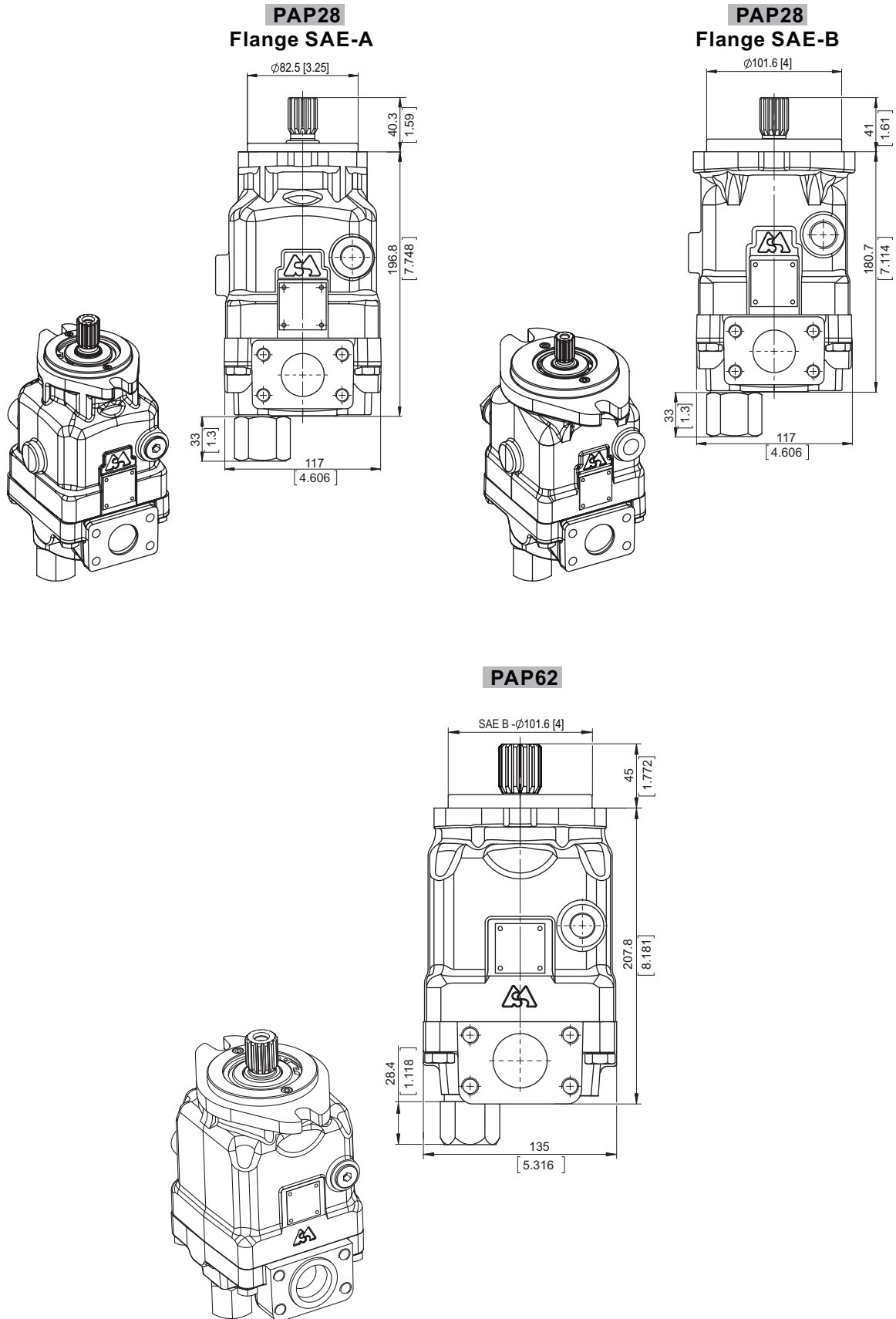

mm [in]

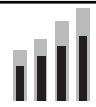

PORT, SHAFT AND FLANGE TYPES

Cross Table - Flange Types For Motors and Pumps

MAP28	MAP62	MAP100	MAPW62	PAP28	PAP62	Type of flanges
x				x		A - 2-Bolt, SAE A; SD-82.5[3.25"];BC-106.35 [4.19"]; BD-13.5 [0.53"]
x	x			x	x	B - 2-Bolt, SAE B; SD-101.6[4"];BC-146 [5.748"]; BD-14.3 [0.563"]
	x	x				4L - 4-Bolt flange; SD-125 [4.92"];BC-160 [6.3"]; BD-14.3 [0.563"]
	x	x				4C - 4-Bolt flange; SAE C; SD-127 [5"];BC-161.92 [6.375"]; BD-14.3 [0.563"]
		x				4M - 4-Bolt flange; ISO 3019-2; SD-140 [5.51"];BC-180 [7.09"]; BD-15 [0.59"]
			x			Cartage - 2-Bolt flange; Wheel flange cartage; SD-160[6.299"]; BC 200[7.874"]

Legend

BC (Bolt Circle) - Center point of bolt holes
 BD (Bolt Diameter) - Diameter of bolt holes
 SD (Spigot Diameter) - Center Diameter

Cross Table - Shaft Types For Motors and Pumps

MAP28	MAP62	MAP100	MAPW62	PAP28	PAP62	Type of shafts
x	x			x	x	SD \varnothing 21.72 [0.855"] Spline SAE 13T 16/32 DP, M8 thread
x	x			x	x	GD \varnothing 21.72 [0.855"] Spline SAE 13T 16/32 DP, 5/16-18 UNC thread
x	x			x	x	SF \varnothing 24.9 [0.98"] Spline SAE 15T 16/32, M8 thread
x	x			x	x	GF \varnothing 24.9 [0.98"] Spline SAE 15T 16/32, 3/8-16 UNC thread
	x		x	x		SH \varnothing 29.6 [1.165"] Spline W30x2x30x14x9g DIN, M10 thread
	x			x		SK \varnothing 31.75 [1.25"] Spline SAE 14T 12/24 DP, M10 thread
	x			x		GK \varnothing 31.75 [1.25"] Spline SAE 14T 12/24 DP, 7/16-14UNC thread
	x			x		SP \varnothing 34.5 [1.358"] Spline SAE 21T 16/32 DP, M12 thread
			x			QH \varnothing 34.6 [1.36"] Spline W35x2x30x16x9g DIN, M12 thread
		x				SR \varnothing 37.6 [1.48"] Spline SAE 23T 16/32 DP, M12 thread
		x				ST \varnothing 39.6 [1.559"] Spline W40x2x30x18x9g DIN 5480, M12 thread
		x				GU \varnothing 44.43 [1.749"] Spline SAE 13T 8/16 DP, 3/8-16 UNC thread
x	x			x	x	CK \varnothing 22.2 [7/8"] Straight , M8 thread, Parallel key 1/4"x1/4"x1" BS46
x	x			x	x	MK \varnothing 22.2 [7/8"] Straight , M8 thread, Parallel key 1/4"x1/4"x1 1/2" BS46
x	x			x	x	ML \varnothing 25 [0.984"] Straight , M8 thread, Parallel key A8x7x25 DIN6885
x	x			x	x	CM \varnothing 25.4 [1"] Straight , M8 thread, Parallel key 1/4"x1/4"x1" BS46
	x			x		DO \varnothing 28.75 [1.125"] Straight , key 7.95[5/16"] , L31.7[1 1/4"] , 3/8-16 UNC thread
	x			x		CQ \varnothing 30 [1.181"] Straight , M8 thread, Parallel key A8x7x32 DIN6885
	x			x		DR \varnothing 31.75 [1.25"] Straight , key 7.95[5/16"] , L31.7[1 1/4"] , 3/8-16 UNC thread
	x			x		CS \varnothing 32 [1.26"] Straight , M8 thread, Parallel key A10x8x45 DIN6885
		x				DU \varnothing 38.1[1.5"] Straight , key 9.528[0.375"] , L38.1[1.5"] , 3/8-16 UNC thread
		x				CV \varnothing 40 [1.575"] Straight , M12 thread, Parallel key A12x8x63 DIN6885
x	x			x		TD \varnothing 22.22 [7/8"] Tapered 1:8 [125:1000], Parallel key 1/4"x1/4"x1", 5/8-18 UNF
	x			x		TH \varnothing 25.4 [1"] Tapered 1:8 [125:1000], Parallel key 1/4"x 1/4"x1", 3/4-16 UNF
	x			x		KH \varnothing 25.4 [1"] Tapered 1:8 [125:1000], Parallel key 1/4"x1/4"x1", M16x1.5 thread
		x				TN \varnothing 31.75 [1.25"] Tapered 125:1000, key 5/16x5/16 L1 1/8, 1-12 UNF thread

PORTS SIZE - THREAD OPTION

MAP28	MAP62	MAP100	MAPW62
default			
	default		default
		default	
5			
	5		5
		5	
9			
	9		9
		9	
2	6		
6	2		2
		2	
3	7		
	3		3
4	8		
	4		4
		4	

Cross Table - Port Types For Motors

PORTS SIZE - THREAD OPTION				Type of threads
MAP28	MAP62	MAP100	MAPW62	
default				2xISO 6162-2 DN13, metric, drain ports M18x1.5
	default		default	2xISO 6162-2 DN19, metric, drain ports M18x1.5
		default		2xISO 6162-2 DN25, metric, drain ports M27x2, rear drain ports M22x1.5
5				2xSAE 1/2" PSI6000, drain ports 3/4-16 UNF
	5		5	2xSAE 3/4" PSI6000, SAE, drain ports 7/8-14 UNF
		5		2xSAE 1", PSI6000, drain ports 1 1/16 UNF, rear drain port 7/8-14 UNF
9				2xISO 6162-2 DN13, drain ports G1/2
	9		9	2xISO 6162-2 DN19, drain ports G1/2
		9		2xISO 6162-2 DN25, drain ports G3/4, rear drain port G1/2
2	6			2xG1/2, drain ports G1/2
6	2		2	2xG3/4, drain ports G1/2
		2		2xG1, drain ports G3/4, for rear drain port G1/2
3	7			2xM22x2, drain ports M22x2
	3		3	2xM27x2, drain ports M18x1.5
4	8			2x7/8-14 UNF Ports, drain ports 3/4-16 UNF
	4		4	2x1 1/16 -12 UN, drain ports 7/8-14 UNF
		4		2x1 1/16 -12 UN Ports, drain ports 1 1/16 -12 UN , rear drain port 7/8-14 UNF

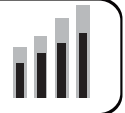

PORT, SHAFT AND FLANGE TYPES

PORTS SIZE - THREAD OPTION		Type of threads
PAP28	PAP62	
default		Inlet ISO 6162-1 DN32, Outlet ISO 6162-2 DN19, drain ports M18x1.5
5		Inlet SAE J518 1 1/2 PSI3000, Outlet SAE J518 3/4 PSI6000, drain ports 7/8-14 UNF
9		Inlet ISO 6162-1 DN32, Outlet ISO 6162-2 DN19, drain ports G1/2
	default	Inlet ISO 6162-1 DN32, Outlet ISO 6162-2 DN19, drain ports M18x1.5
	5	Inlet SAE J518 1 1/2 PSI3000, Outlet SAE J518 3/4 PSI6000, drain ports 7/8-14 UNF
	9	Inlet ISO 6162-1 DN32, Outlet ISO 6162-2 DN19, drain ports G1/2

VALVE OPTIONS FOR MOTORS

Anti-Cavitation Valve

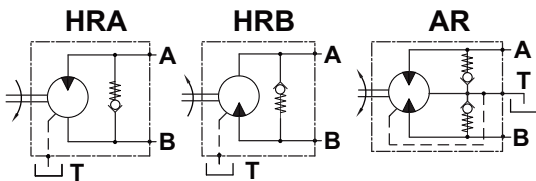

Combined Anti-Cavitation and Relief Valve

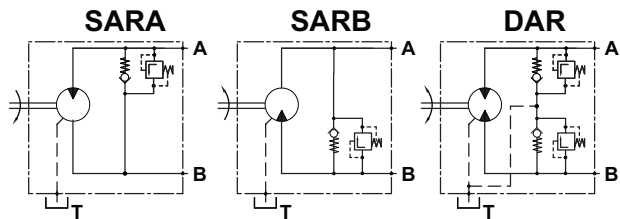

Purge Valve

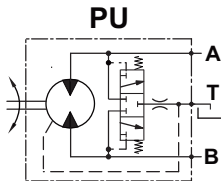

Flush Valve

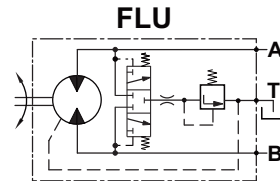

Dual Anti-Cavitation, Relief and Purge Valve

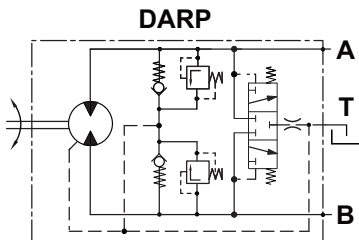

Dual Anti-Cavitation, Relief and Flush Valve

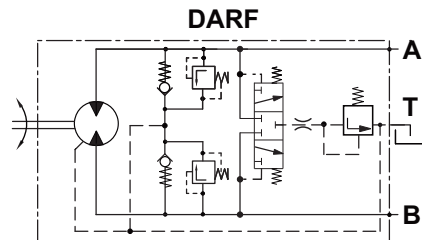

Cross Table - Valve Types

Type of valves	MAP28			MAP62			MAP100			MAPW62		
	omit	T	E	omit	T	E	omit	T	E	omit	T	E
HRA	x	x	x	x	x	x	x	x	x	x	x	x
HRB	x	x	x	x	x	x	x	x	x	x	x	x
AR	x	x		x	x	x	x	x	x	x	x	x
SARA	x	x		x	x	x	x	x	x	x	x	x
SARB	x	x		x	x	x	x	x	x	x	x	x
DAR	x	x		x	x	x	x	x	x	x	x	x
PU	x	x	x	x	x	x	x	x	x	x	x	x
FLU	x	x	x	x	x	x	x	x	x	x	x	x
DARP		x		x	x		x	x	x	x	x	
DARF		x		x	x		x	x	x	x	x	

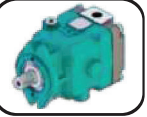

Hydraulic Motors Type MAP28

Heavy Duty Axial Piston Motors Fixed Displacement

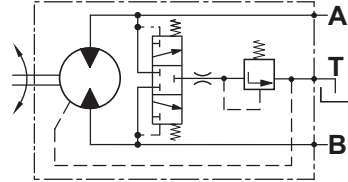
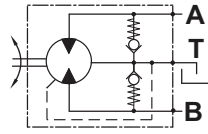
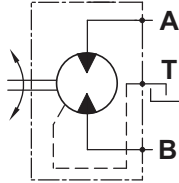

open drain line is always required

APPLICATION

- » Agricultural machines
- » Road building machines
- » Mining machinery
- » Food industry machines
- » Swing drives
- » Hydraulic transmissions
- » Vibration machines
- » Fan drives
- » Special vehicles

OPTIONS

- » Flange options
- » Port options
- » Shaft options
- » High pressure ports
- » Integrated valves

ADVANTAGES

- » High starting torque
- » Smooth operation
- » Long service life
- » High power density

GENERAL

Displacement,	cm ³ /rev [in ³ /rev]	22.15÷28.47 [1.35÷1.74]
Max. Speed,	RPM	4200
Max. Torque,	Nm [lb-in]	159 [1407]
Max. Output,	kW [HP]	48 [64]
Max. Pressure Drop,	bar [PSI]	350 [5080]
Max. Oil Flow,	l/min [GPM]	120 [31.7]
Min. Speed,	RPM	500
Fluid	Mineral based- HLP(DIN 51524) or HM(ISO 6743/4)	
Temperature Range,	°C [°F]	-40÷82 [-40÷180]
Optimal Viscosity Range,	mm ² /s [SUS]	12÷68 [66÷311]
Filtration	ISO code 18/16/13 (Min. recommended fluid filtration of 10 micron)	

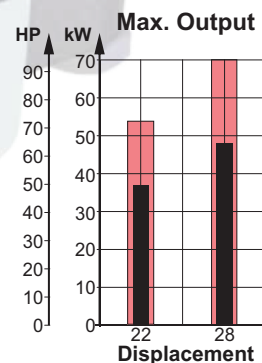
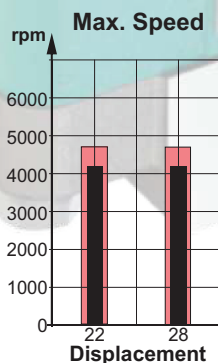
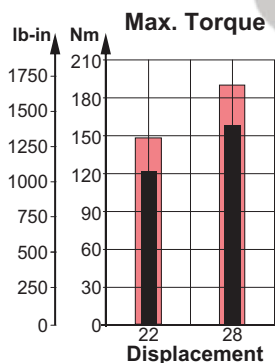

Intermittent values

Continuous values

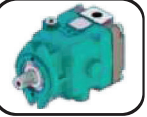

SECTION VIEW

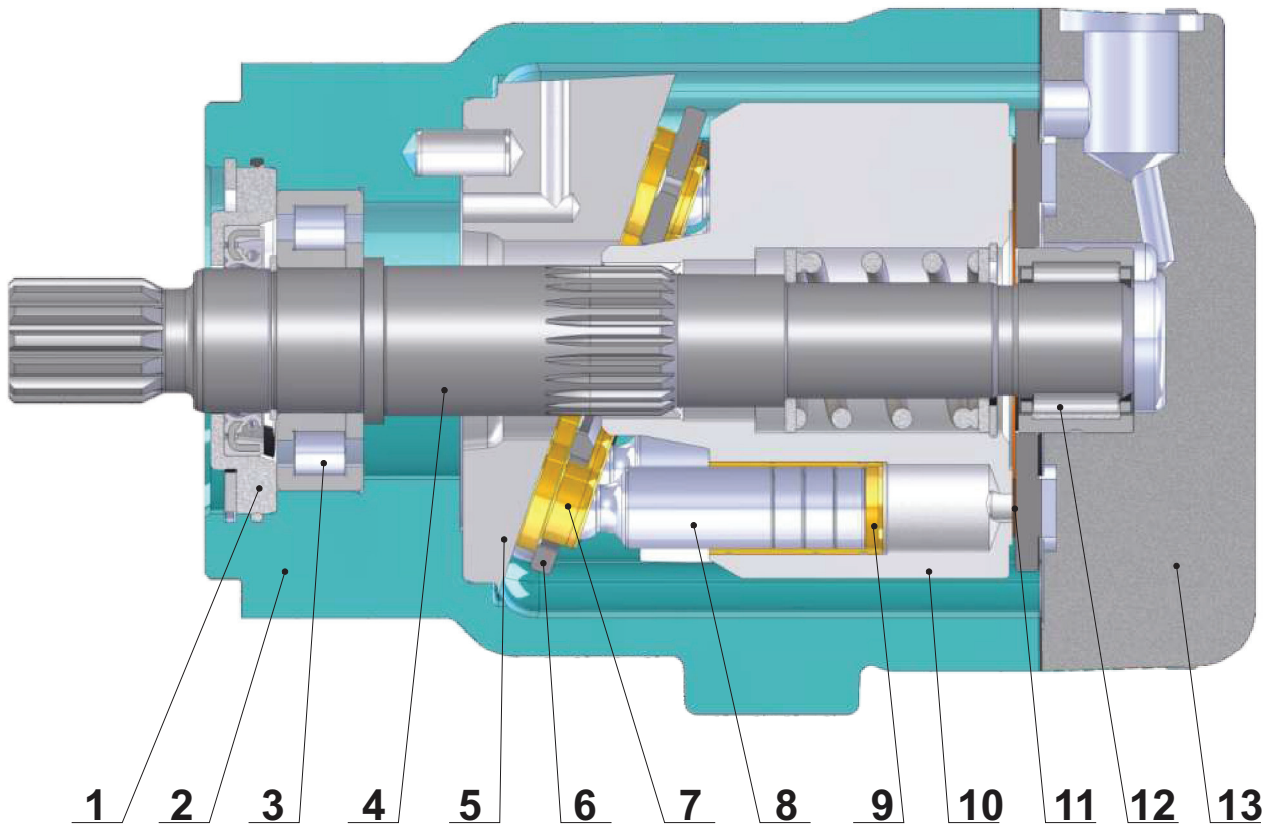

1. Front cover
2. Cast iron body
3. Robust radial - axial roller bearing
4. Hardened shaft
5. Solid swash plate
6. Retainer plate
7. Improved piston shoes
8. Improved pistons
9. Brass bushings
10. Hardened steel cylinder block
11. Bimetal distributor
12. Needle bearing
13. Solid end cover

The main advantages of the heavy duty design of the MAP motors over the typical swash plate motors are the higher starting torque and the higher total efficiency. In regards to these two parameters, under normal working mode, the MAP is comparable to the bent axis motors. The advantages of the MAP over the bent axis motors are the higher reliability and the lower degree of pulsation and vibration during operation.

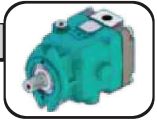

SPECIFICATION DATA

Type		MAP 22	MAP 28
Displacement, cm ³ /rev [in ³ /rev]		22.15 [1.35]	28.47 [1.74]
Max. Speed, [RPM]	Cont.	4200	4200
	Int.*	4700	4700
Max. Torque,*** Nm [lb-in]	Cont.	123 [1088]	159 [1407]
	Int.**	148 [1310]	190 [1682]
Output, kW [HP]	Cont.	37 [50]	48 [64]
	Int.**	54 [72]	70 [94]
Max. Pressure, bar [PSI]	Cont.	350 [5080]	350 [5080]
	Int.**	420 [6100]	420 [6100]
	Peak	450 [6527]	450 [6527]
Max. Oil Flow, l/min[GPM]	Cont.	93 [24.6]	120 [31.7]
	Int.*	104 [27.5]	134 [35.4]
Torque Constant ***** Nm/bar [lb-in/PSI]		0.32 [0.194]	0.41 [0.25]
	Speed Constant ***** RPM/(l/min) [RPM/GPM]	42.9 [162.4]	33.4 [126.3]
Permissible Shaft Load	max Axial**** N[lb]	Fa=1300 [292]	
	max Radial**** N[lb]	Fr=2200 [495]	
Min. Speed, [RPM]		500	
Max. Pressure in Drain Line, bar [PSI]		5 [70] open drain line is always required	
Weight, kg [lb]		10.79 [23.79] for SAE-A flange	
		11.50 [25.35] for SAE-B flange	

Peak pressure is the highest allowable pressure, may occur for max. 1% of every minute;

* Intermittent speed (flow): for pressure up to 150[2200] bar[PSI];

** Intermittent load: the permissible values may occur for max. 10% of motor lifetime;

*** Theoretical torque;

**** The calculated max values are based on the optimal direction of the forces Fr, Fa and optimal position of the shaft.

***** The constant values are used for calculation of torque and speed with motor efficiencies $\eta_v=0.95$ and $\eta_{mh}=0.9$.

1. The recommended output power for continuous operations should not be exceeded.
2. Recommended filtration as per ISO 4406 cleanliness code 18/16/13 or better. This filtration corresponds to SAE AS 4059 8A/7B/7C. Nominal filtration - 10 micron or better.
3. Recommended a premium quality, anti-wear type mineral based hydraulic oil, HLP(DIN51524) or HM(ISO6743/4).
4. Recommended oil viscosity - 12...68 cSt or see page 84.
5. Recommended maximum system operating temperature - 82°[180°] C[F].
6. To ensure optimum life of the motor, fill it up with fluid prior to load it and run with moderate load and speed for about 10-15 minutes.

Hint: Motor Torque = Torque Constant * Pressure Drop

Rotation Speed = Speed Constant * Oil Flow

The constant values are approximate. Motor torque and rotation speed for a particular project are depending on the real operating conditions. For more detailed calculations please see efficiencies on page 74 and formulas on page 85.

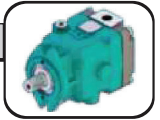

OVERALL DIMENSIONS AND PORTS

Side Ports - Default Mounting Flange - Type SAE-A

Standard Rotation
Viewed from shaft end
Port A Pressurized - CW
Port B Pressurized - CCW
see page 81

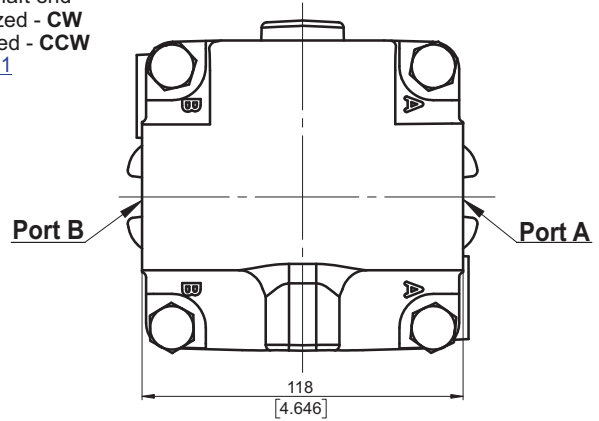
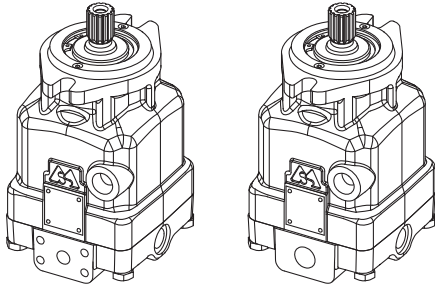

Side ports, port size default, 5 and 9

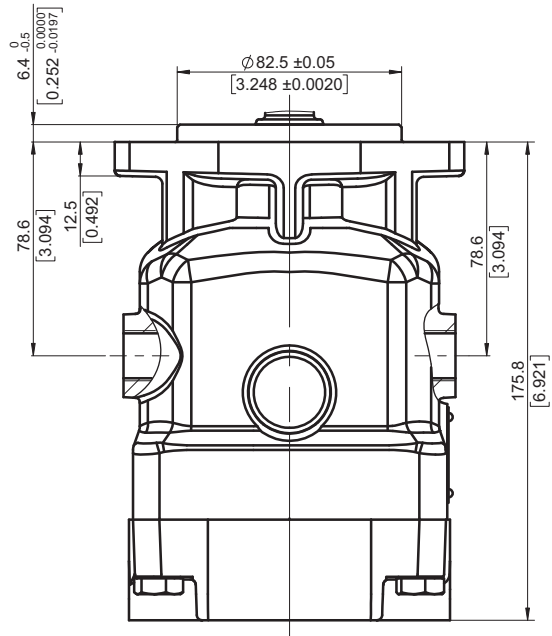
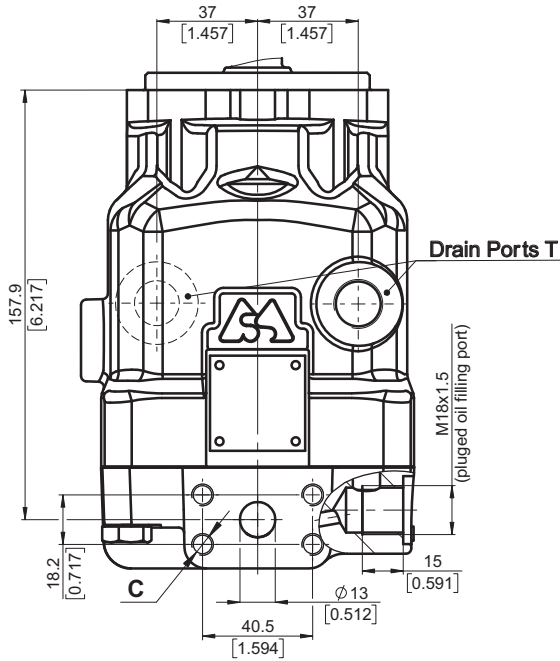

	Port Size		
	default	5	9
P _{A,B}	2xISO 6162-2 DN13	2xSAE J518 1/2" PSI6000	2xISO 6162-2 DN13
T	M18x1.5	3/4-16 UNF	G1/2
C	8xM8	8x5/16-18 UNC	8xM8

Side ports, port size 2, 3, 4 and 6

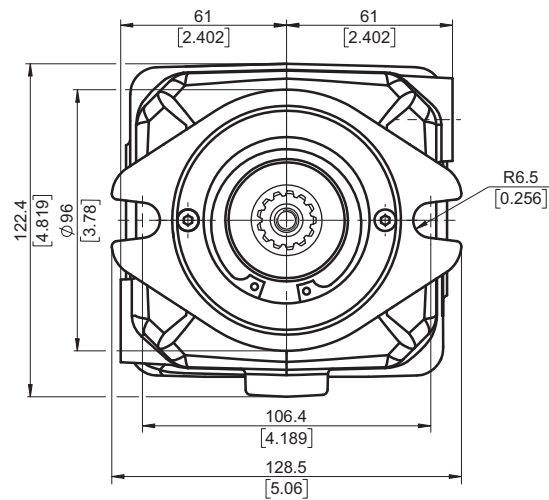
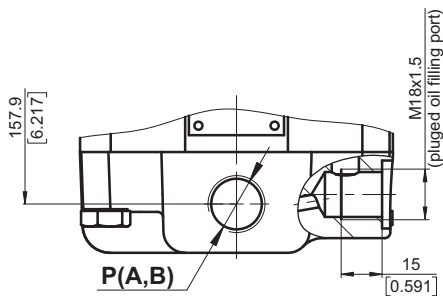

	Port Size			
	2	3	4	6
P _{A,B}	2xG 1/2	2xM22x1.5	2x7/8-14UNF	2xG 3/4
T	G 1/2	M18x1.5	3/4-16UNF	G 1/2

Shaft Mounting
see page 14

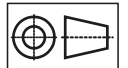

mm [in]

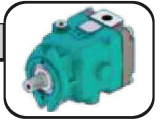

OVERALL DIMENSIONS AND PORTS

Rear Ports - Type E Mounting Flange - Type SAE-A

Standard Rotation
Viewed from shaft end
Port A Pressurized - CW
Port B Pressurized - CCW
see page 81

Rear ports E, port size default, 5 and 9

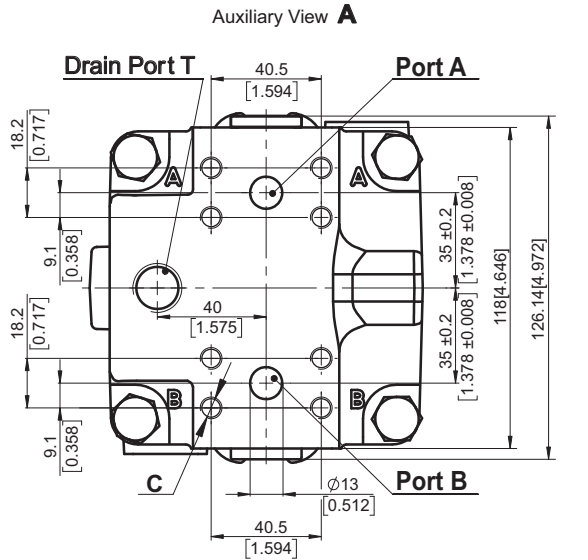

	Port Size		
	default	5	9
P _(A,B)	2xISO 6162-2 DN13	2xSAE J518 1/2" PSI6000	2xISO 6162-2 DN13
T	M18x1.5	3/4-16 UNF	G1/2
C	8xM8	8x5/16-18 UNC	8xM8

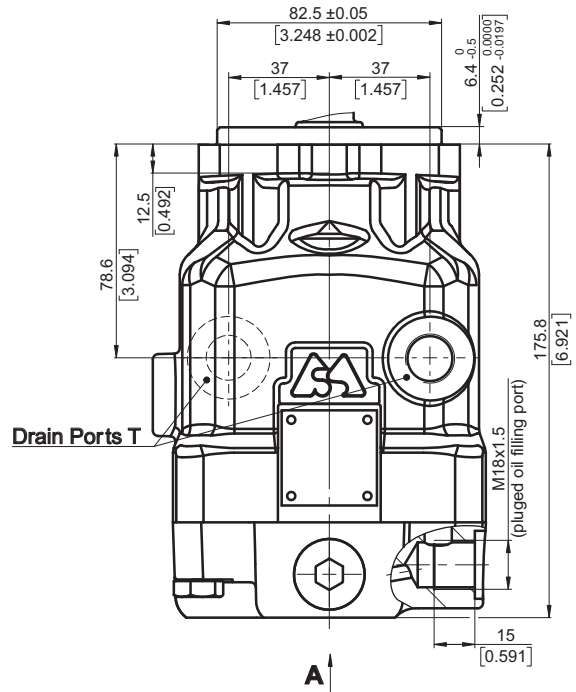
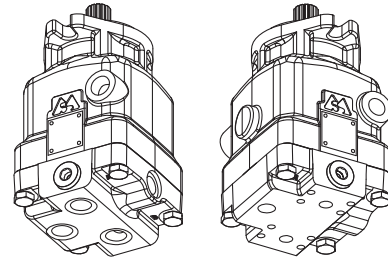

Rear ports E, port size 2, 3, 4 and 6

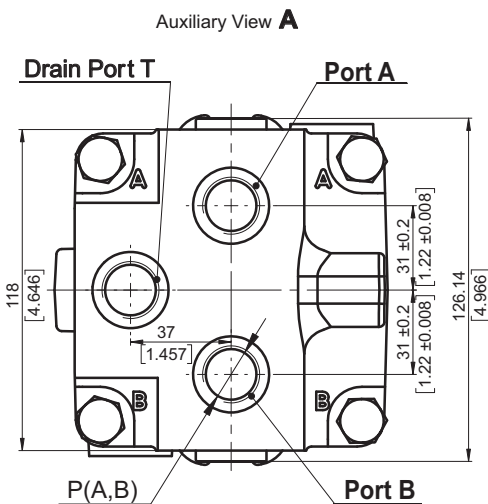

	Port Size			
	2	3	4	6
P _(A,B)	2xG 1/2	2xM22x1.5	2x7/8-14 UNF	2xG 3/4
T	G 1/2	M18x1.5	3/4-16 UNF	G 1/2

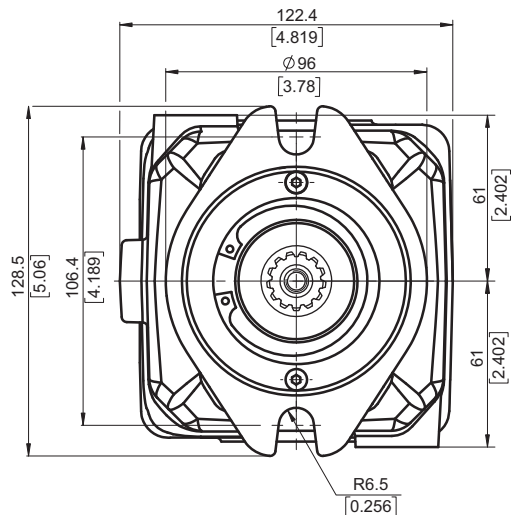

Shaft Mounting
see page 14

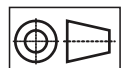

mm [in]

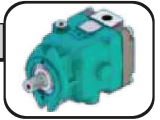

OVERALL DIMENSIONS AND PORTS

Twin Side Ports - Type T Mounting Flange - Type SAE-A

Twin side ports T, port size 2,3,4 and 6

See the port sizes at the bottom of this page

Standard Rotation
Viewed from shaft end
Port A Pressurized - CW
Port B Pressurized - CCW
see page 81

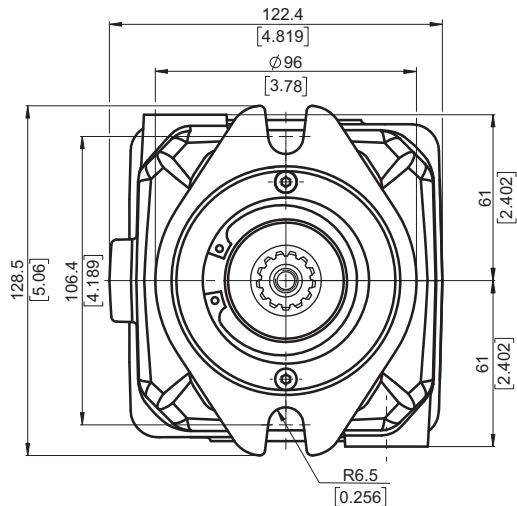
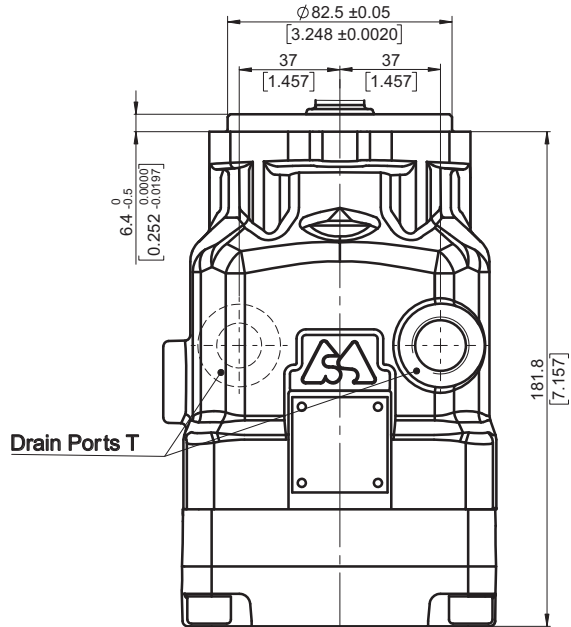
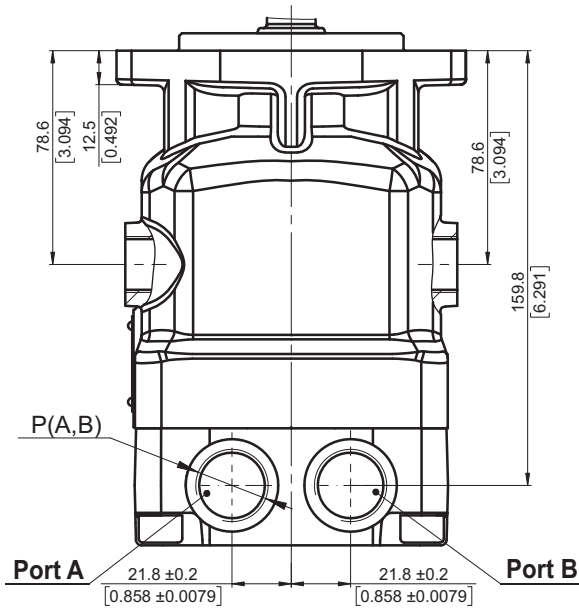
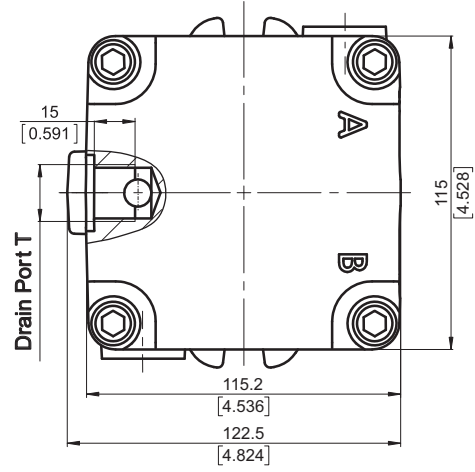
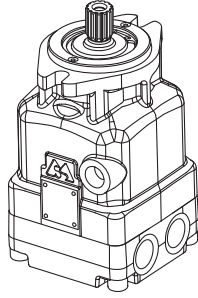

		Port Size			
		2	3	4	6
P _(A,B)		2xG 1/2	2xM22x1.5	2x7/8-14UNF	2xG 3/4
T		G 1/2	M18x1.5	3/4-16UNF	G 1/2

Shaft Mounting
see the next page

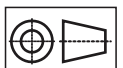

mm [in]

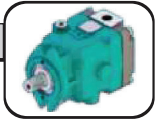

SHAFTS MOUNTING

Mounting Flange - Type SAE-A

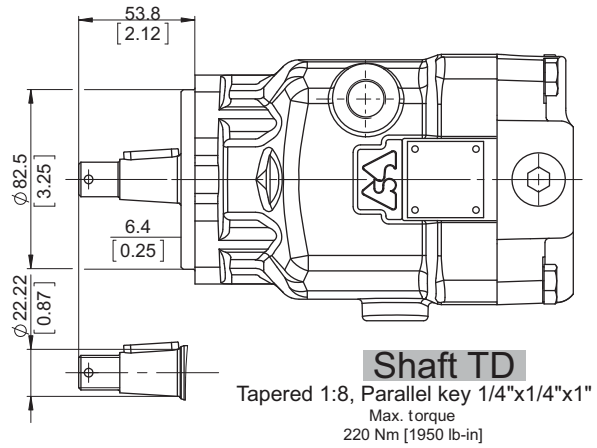
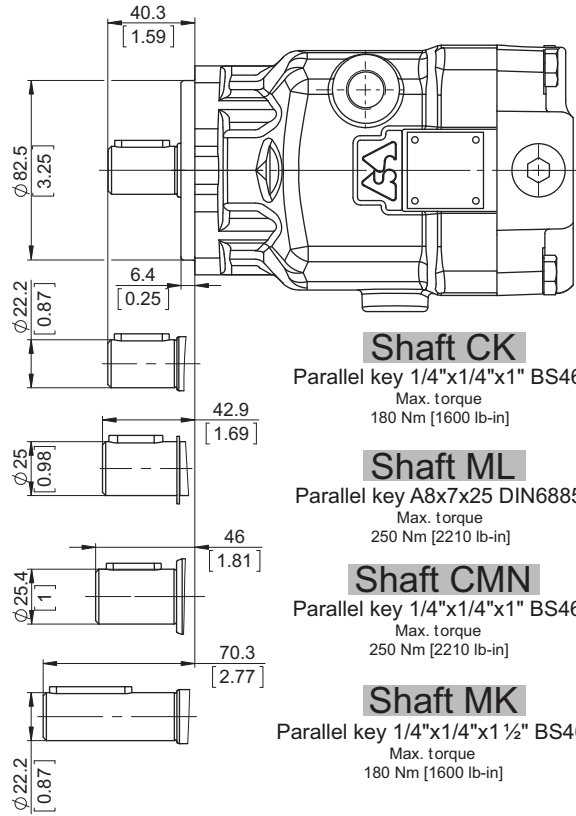
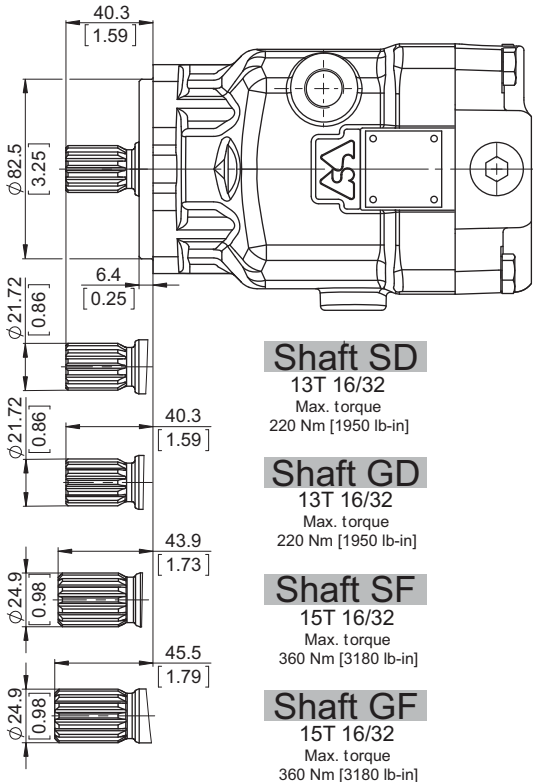

Shaft Dimensions
See Page 69+73

PERMISSIBLE SHAFT LOAD

Permissible shaft load		Standard bearing	CMN bearing
max Axial	N[lb]	Fa=1300 [292]	Fa=1600 [360]
max Radial	N[lb]	Fr=2200 [495]	Fr=3000 [674]

The calculated max values are based on the optimal direction of the forces Fr, Fa and optimal position of the shaft (see page 81).

For more information, please, feel free to contact us.

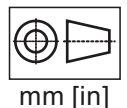

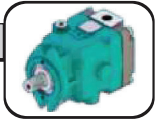

OVERALL DIMENSIONS AND PORTS

Side Ports - Default Mounting Flange - Type SAE-B

Standard Rotation
Viewed from shaft end
Port A Pressurized - CW
Port B Pressurized - CCW
see page 81

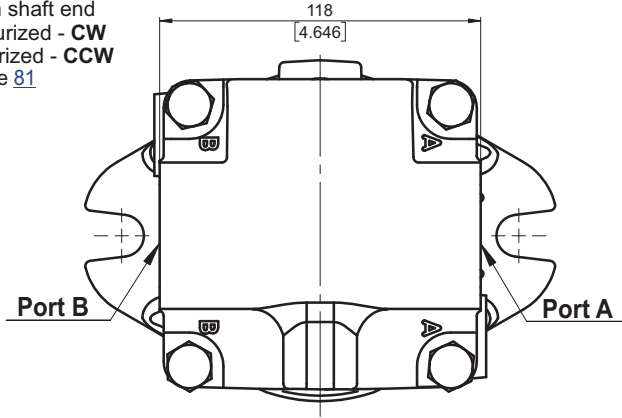
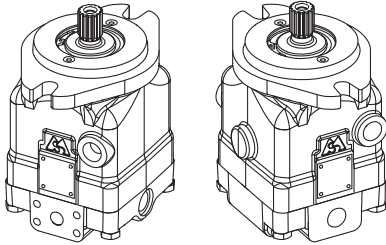

Side ports, port size default ,5 and 9

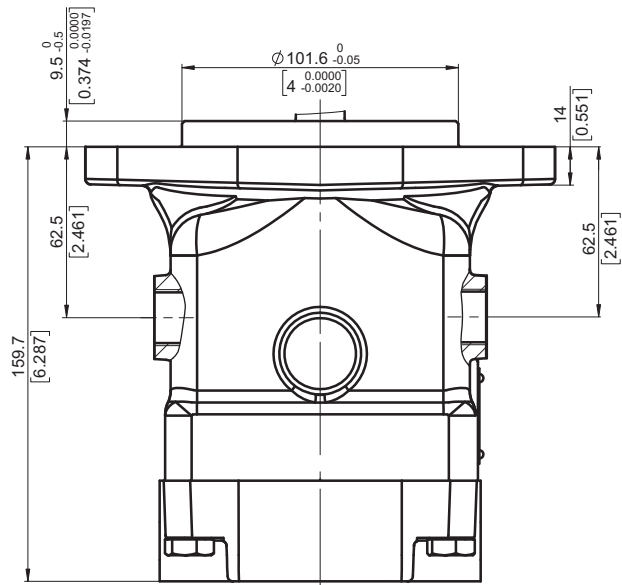
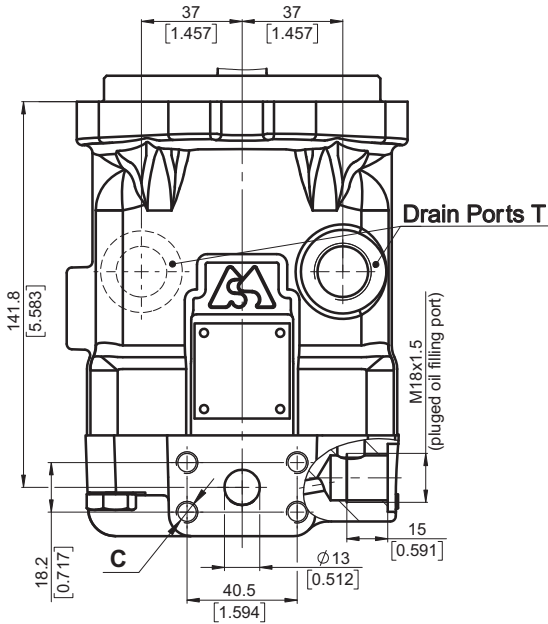

	Port Size		
	default	5	9
P _(A,B)	2xISO 6162-2 DN13	2xSAE J518 1/2" PSI6000	2xISO 6162-2 DN13
T	M18x1.5	3/4-16 UNF	G1/2
C	8xM8	8x5/16-18 UNC	8xM8

Side ports, port size 2, 3, 4 and 6

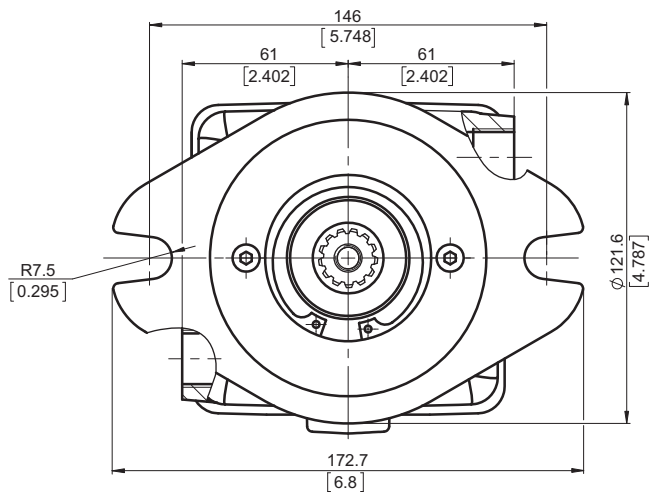
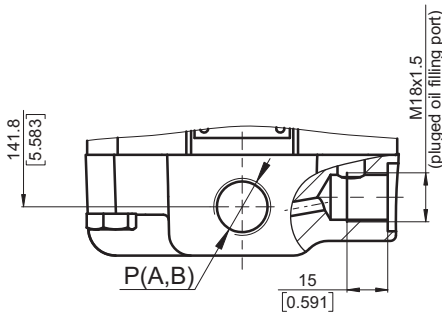

	Port Size			
	2	3	4	6
P _(A,B)	2xG 1/2	2xM22x1.5	2x7/8-14UNF	2xG 3/4
T	G 1/2	M18x1.5	3/4-16UNF	G 1/2

Shaft Mounting
see page 18

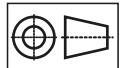

mm [in]

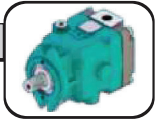

OVERALL DIMENSIONS AND PORTS

Rear Ports - Type E Mounting Flange - Type SAE-B

Standard Rotation
Viewed from shaft end
Port A Pressurized - CW
Port B Pressurized - CCW
see page 81

Rear ports E, port size default, 5 and 9

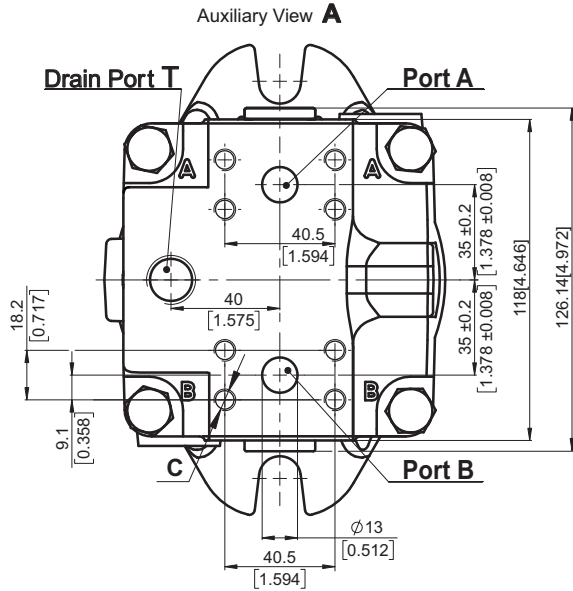

	Port Size		
	default	5	9
P _(A,B)	2xISO 6162-2 DN13	2xSAE J518 1/2" PSI6000	2xISO 6162-2 DN13
T	M18x1.5	3/4-16 UNF	G1/2
C	8xM8	8x5/16-18 UNC	8xM8

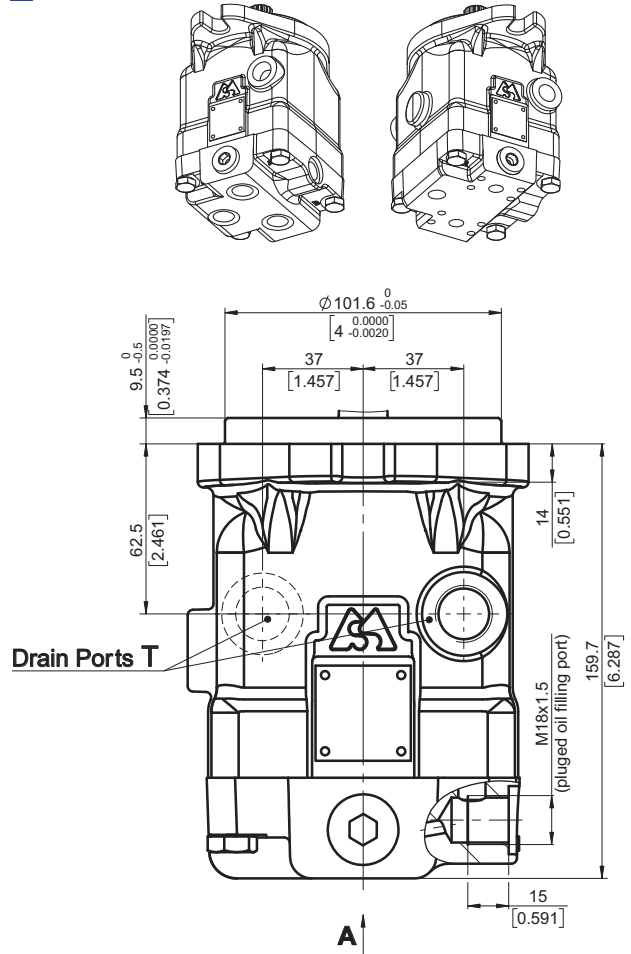

Rear ports E, port size 2, 3, 4 and 6

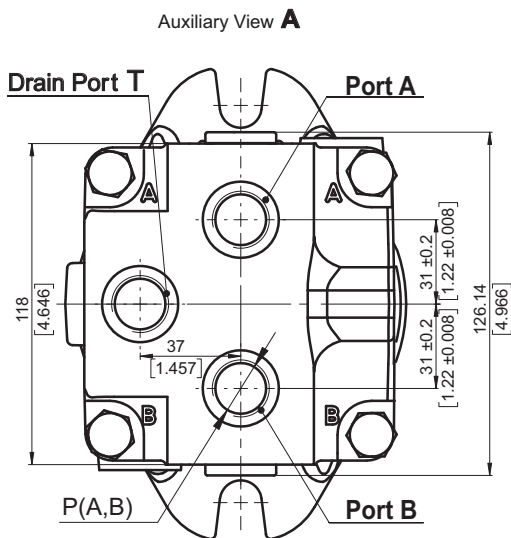

	Port Size			
	2	3	4	6
P _(A,B)	2xG 1/2	2xM22x1.5	2x7/8-14UNF	2xG 3/4
T	G 1/2	M18x1.5	3/4-16UNF	G 1/2

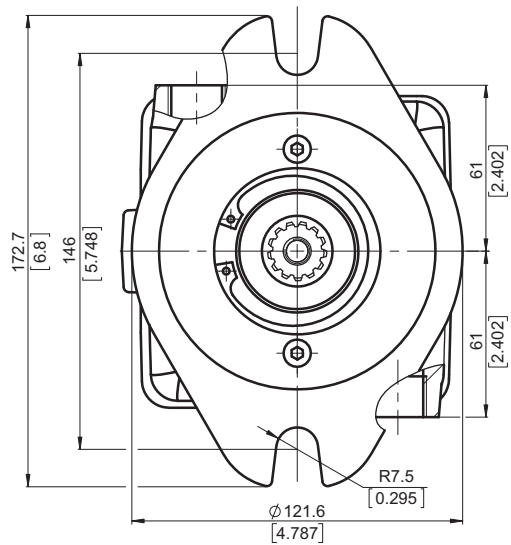

Shaft Mounting
see page 18

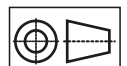

mm [in]

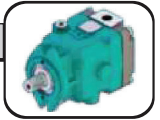

OVERALL DIMENSIONS AND PORTS

Twin Side Ports - Type T Mounting Flange - Type SAE-B

Twin side ports T, port size 2,3,4 and 6

See the port sizes at the bottom of this page

Standard Rotation
Viewed from shaft end
Port A Pressurized - CW
Port B Pressurized - CCW
see page 81

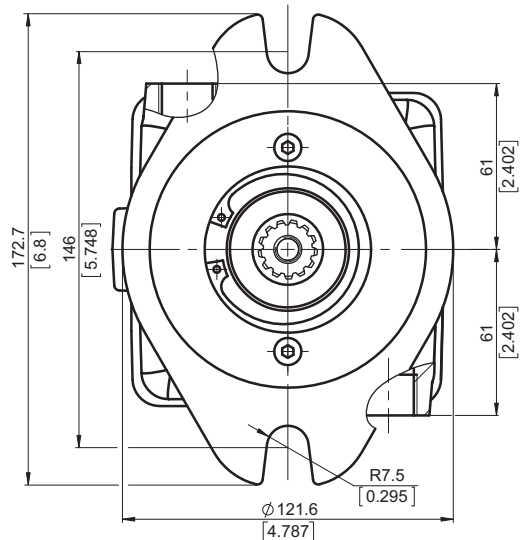
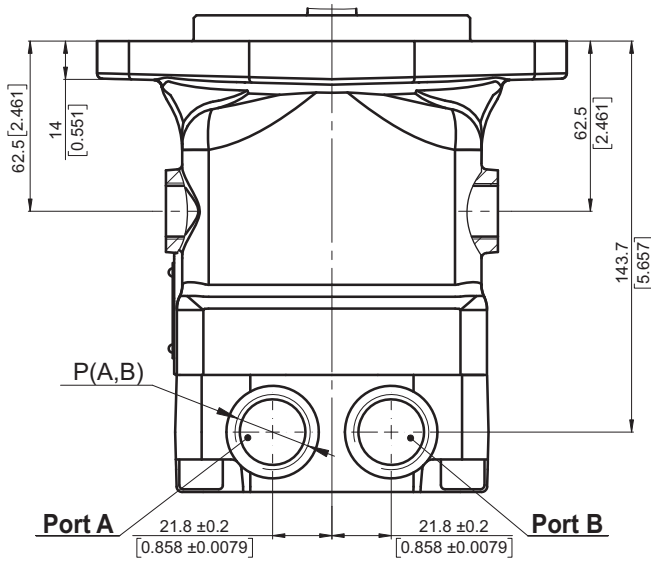
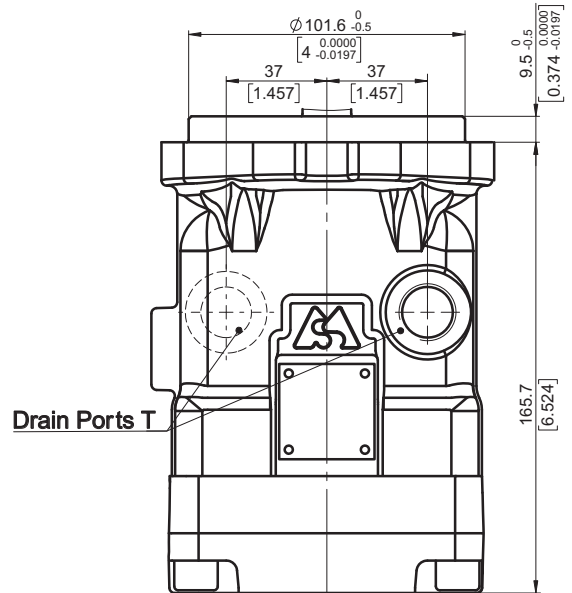
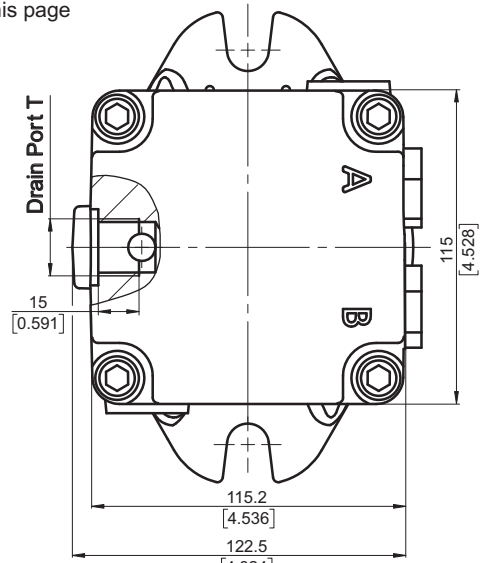
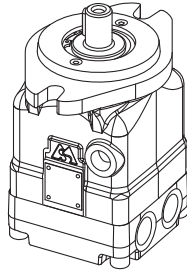

	Port Size			
	2	3	4	6
P _(A,B)	2xG 1/2	2xM22x1.5	2x7/8-14UNF	2xG 3/4
T	G 1/2	M18x1.5	3/4-16UNF	G 1/2

Shaft Mounting
see the next page

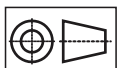

mm [in]

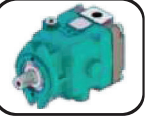

SHAFTS MOUNTING

Mounting Flange - Type SAE-B

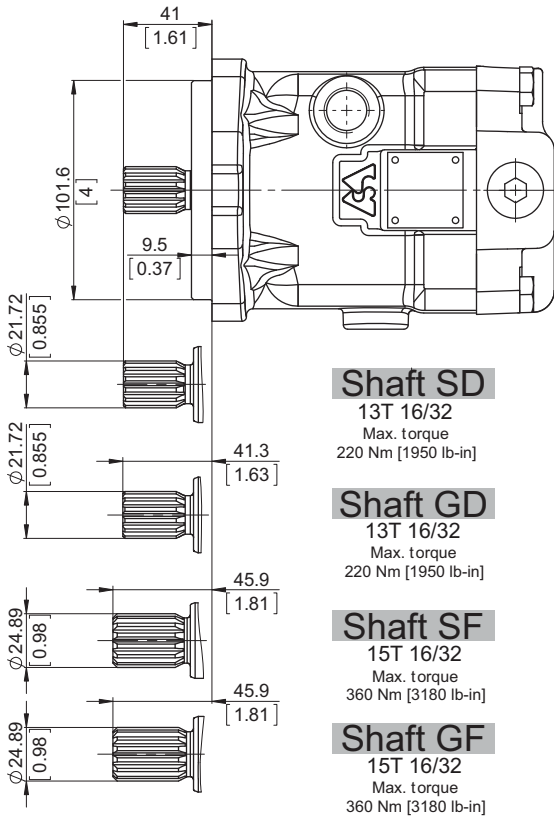

Shaft SD

13T 16/32
Max. torque
220 Nm [1950 lb-in]

Shaft GD

13T 16/32
Max. torque
220 Nm [1950 lb-in]

Shaft SF

15T 16/32
Max. torque
360 Nm [3180 lb-in]

Shaft GF

15T 16/32
Max. torque
360 Nm [3180 lb-in]

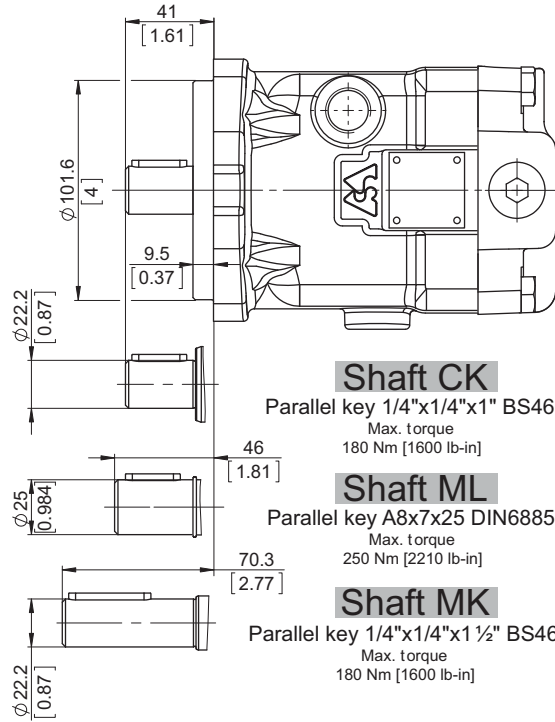

Shaft CK

Parallel key 1/4"x1/4"x1" BS46
Max. torque
180 Nm [1600 lb-in]

Shaft ML

Parallel key A8x7x25 DIN6885
Max. torque
250 Nm [2210 lb-in]

Shaft MK

Parallel key 1/4"x1/4"x1 1/2" BS46
Max. torque
180 Nm [1600 lb-in]

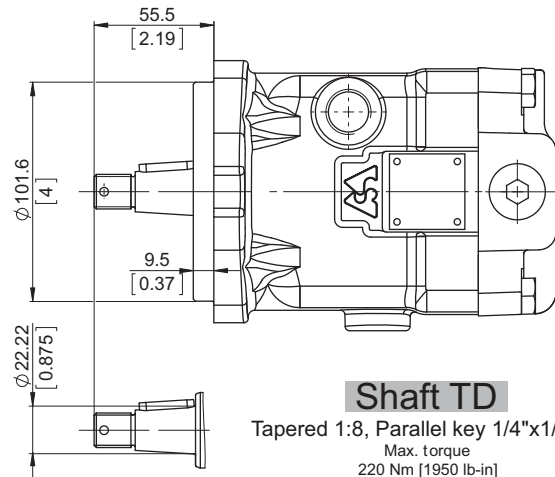

Shaft TD

Tapered 1:8, Parallel key 1/4"x1/4"x1"
Max. torque
220 Nm [1950 lb-in]

Shaft Dimensions
See Page 69+73

PERMISSIBLE SHAFT LOAD

Permissible shaft load		Standard bearing
max Axial	N[lb]	Fa=1300 [292]
max Radial	N[lb]	Fr=2200 [495]

The calculated max values are based on the optimal direction of the forces Fr, Fa and optimal position of the shaft (see page 81).

For more information, please, feel free to contact us.

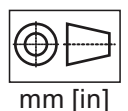

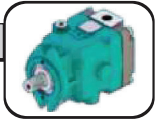

ORDERING CODE

	1	2	3	4	5	6	7	8	9	10	11	12	13	13	13
M	A	P											[]

Pos.1 - Mounting Flange

- A** - 2-Bolt flange, SAE A, spigot dia. 82.5 [3.25"], BC 106.35 [4.19"], Bolt Dia. 13.5 [0.53"]
- B** - 2-Bolt flange, SAE B, spigot dia. 101.6 [4"], BC 146 [5.748"], Bolt Dia. 14.3 [0.563"]

Pos.2 - Port Type

- omit - Side ports on opposite sides
- T** - Twin (Two) side ports on one side
- E** - Rear ports

Pos.3 - Displacement Code

- 22** - 22.15 cm³/rev [1.35 in³/rev]
- 28** - 28.47 cm³/rev [1.74 in³/rev]

Pos.4 - Shaft Extensions**

- SD** - ø21.72 [0.855"] Spline SAE 13T 16/32 DP, M8 thread
- GD** - ø21.72 [0.855"] Spline SAE 13T 16/32 DP, 5/16-18 UNC thread
- SF** - ø24.9 [0.98"] Spline SAE 15T 16/32, M8 thread
- GF** - ø24.9 [0.98"] Spline SAE 15T 16/32, 3/8-16UNC thread
- CK** - ø22.2 [7/8"] Straight, M8 thread Parallel key 1/4"x1/4"x1" BS46
- MK** - ø22.2 [7/8"] Straight, M8 thread Parallel key 1/4"x1/4"x1 1/2" BS46
- ML** - ø25 [0.984"] Straight, M8 thread Parallel key A8x7x25 DIN6885
- CMN** - ø25.4 [1"] Straight, M8 thread Parallel key 1/4"x1/4"x1" BS46
- TD** - ø22.22 [7/8"] Tapered 1:8 [125:1000], Parallel key 1/4"x1/4"x1", 5/8-18 UNF-2A

Shaft type CMN is available only for Pos.1 option A

Pos.5 - Port Size

- omit - 2xISO 6162-2 DN13, drain port M18x1.5
- 2** - 2xG1/2, drain ports G1/2
- 3** - 2xM22x2, drain ports M18x1.5
- 4** - 2x7/8-14 UNF Ports, drain ports 3/4-16 UNF
- 5** - 2xSAE 1/2" PSI6000, drain ports 3/4-16 UNF
- 6** - 2xG3/4, drain ports G1/2
- 9** - 2xISO 6162-2 DN13, drain port G1/2

Option omit;5 and 9 are not available for Pos.2 option T

Pos.6 - Seal, Corrosion Resistant Seal Surface

- omit - NBR seal type material
- V** - FKM seal type material

Pos.7 - Integrated Valves

See page 77+78 for information about valves

- omit - None
- HR** - Single anti-cavitation valve
- AR** - Dual anti-cavitation valve
- PU** - Purge valve - default - 5±2 l/min
- FLU** - Flush valve - default - 5±2 l/min at 20 bar
- SAR** - Single anti-cavitation and relief valve
- DAR** - Dual anti-cavitation and relief valve
- DARP** - Dual anti-cavitation, relief and purge valve, default flow - 5±2 l/min
- DARF** - Dual anti-cavitation, relief and flush valve, default flow - 5±2 l/min at 20 bar

Option DAR, SAR, AR and HR are not available for Pos.2 option E
Option FLU are not available for Pos.2 option E combine with Pos.5 option 1 and 5
Option DARF and DARP are available only for Pos.2 option T

Pos.8 - Valve Ports for Single Valves

- omit - None
- A** - Port A
- B** - Port B

Pos.9 - Pressure Setting of Integrated Valves

- omit - None
- x** -

250	300	350*
-----	-----	------

* 350 bar option are available only for Pos.2 option T. for more information see page 77+78

Pos.10 - Flow Setting of Integrated Valves

- omit - None
- Lx** - For value - see page 77+78

Pos.11 - Special Features*

- omit - None
- R2S** - Speed Sensor Two Directional (see page 79)
- R** - Reverse Rotation (see page 81)

Pos.12 - Paint and Coating

- omit - No paint or coating
- P** - Painted
- PC** - Corrosion protected paint

If a painting option is required, the standard color is black-Alkyd-Styrenated Enamel, Black RAL 9005. Other colors - on customer's request.

Pos.13 - Design Series

- omit - Factory specified

**The permissible output torque for shafts must not be exceeded!

EXAMPLE

MAPB28SD2

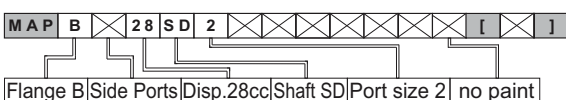

MAPAE22SD4P

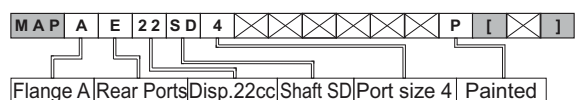

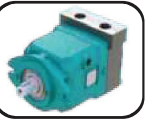

Hydraulic Motors Type MAP62

Heavy Duty Axial Piston Motors Fixed Displacement

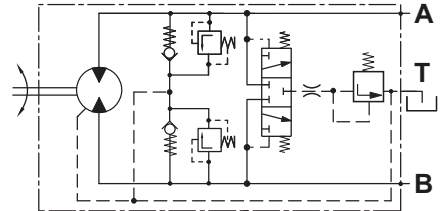
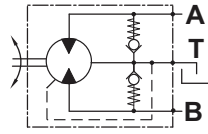
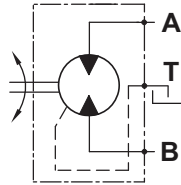

open drain line is always required

APPLICATION

- » Agricultural machines
- » Road building machines
- » Mining machinery
- » Food industry machines
- » Swing drives
- » Hydraulic transmissions
- » Vibration machines
- » Fan drives
- » Special vehicles

OPTIONS

- » Port options
- » Shaft options
- » High pressure ports
- » Integrated valves

ADVANTAGES

- » High starting torque
- » Smooth operation
- » Long service life
- » High power density

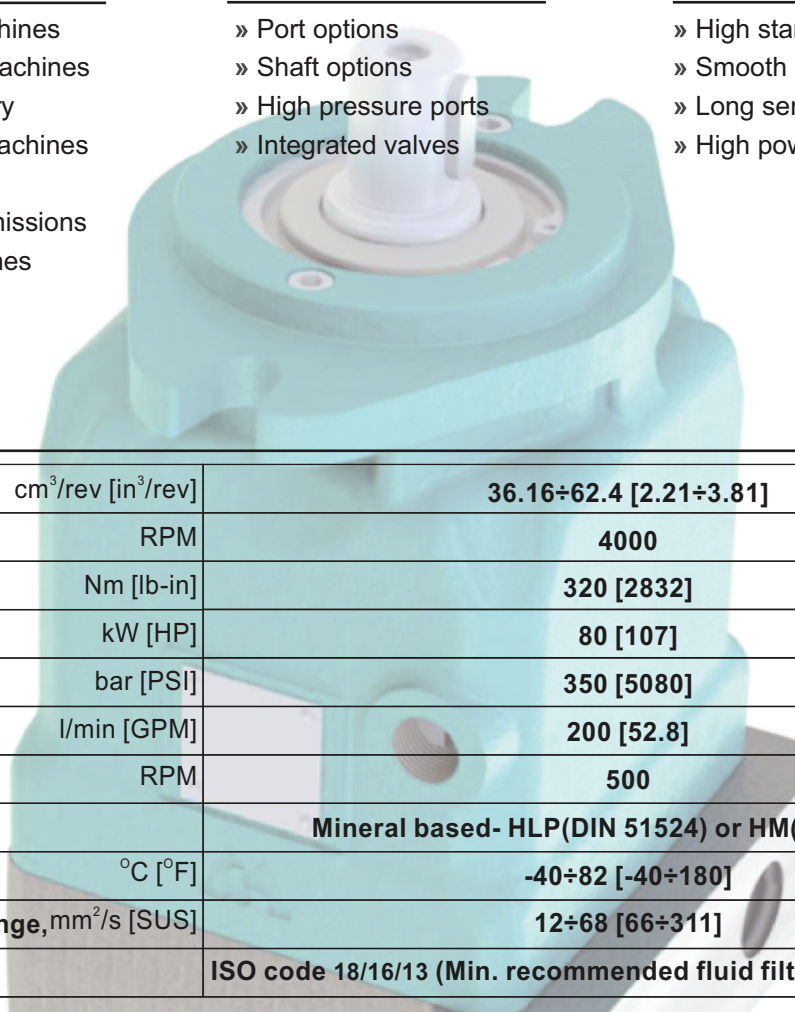

GENERAL

Displacement,	cm ³ /rev [in ³ /rev]	36.16÷62.4 [2.21÷3.81]
Max. Speed,	RPM	4000
Max. Torque,	Nm [lb-in]	320 [2832]
Max. Output,	kW [HP]	80 [107]
Max. Pressure Drop,	bar [PSI]	350 [5080]
Max. Oil Flow,	l/min [GPM]	200 [52.8]
Min. Speed,	RPM	500
Fluid	Mineral based- HLP(DIN 51524) or HM(ISO 6743/4)	
Temperature Range,	°C [°F]	-40÷82 [-40÷180]
Optimal Viscosity Range,	mm ² /s [SUS]	12÷68 [66÷311]
Filtration	ISO code 18/16/13 (Min. recommended fluid filtration of 10 micron)	

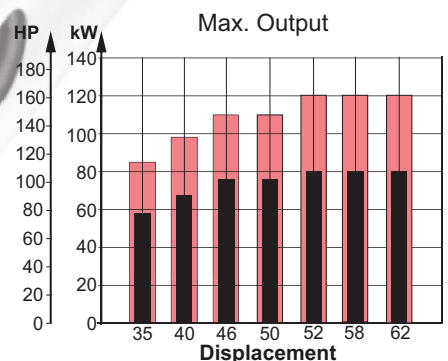
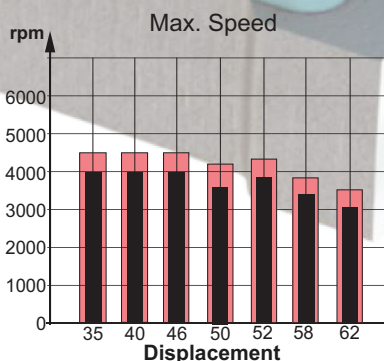
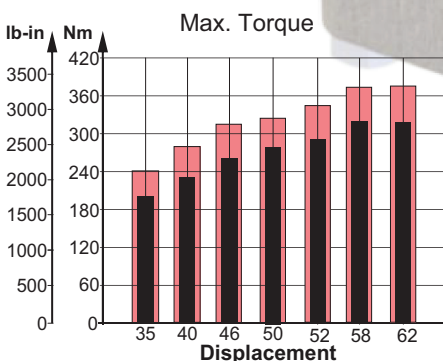

Intermittent values

Continuous values

SECTION VIEW

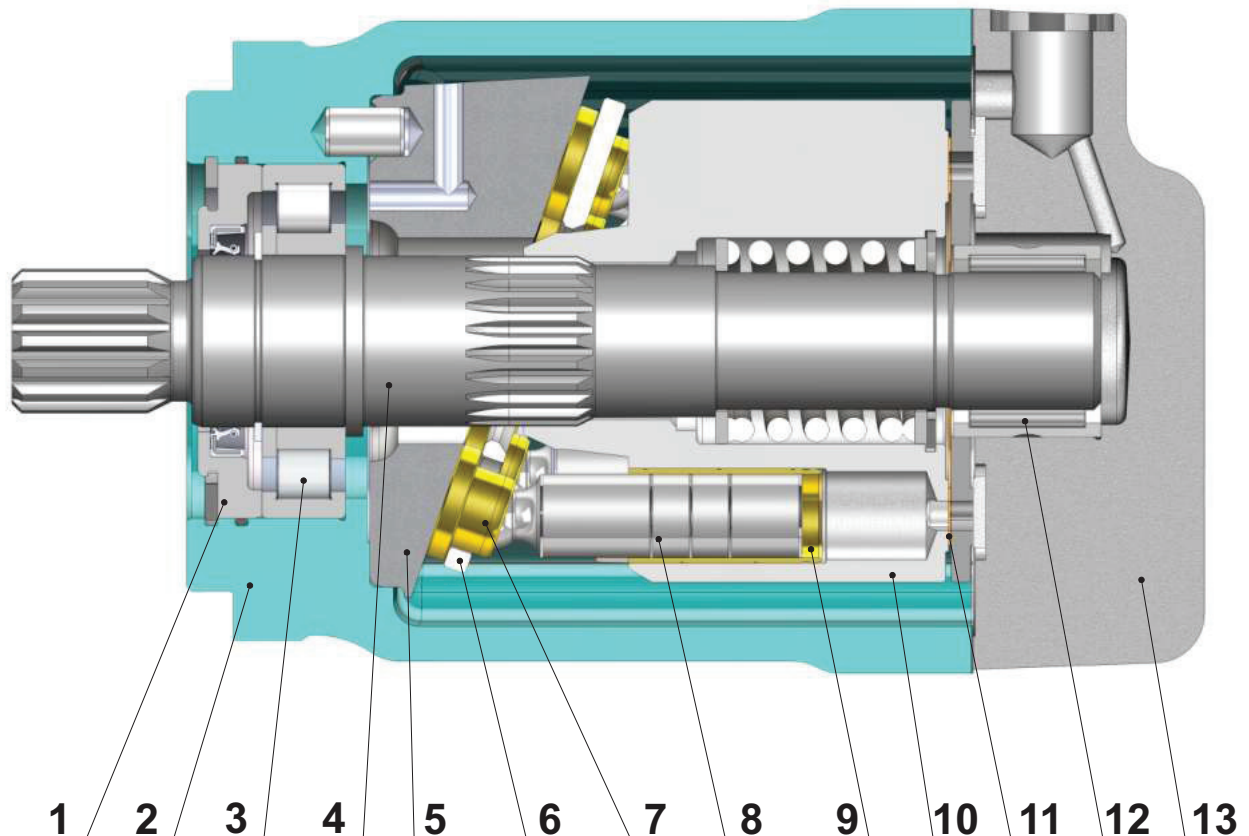

1. Front cover
2. Cast iron body
3. Robust radial - axial roller bearing
4. Hardened shaft
5. Solid swash plate
6. Retainer plate
7. Improved piston shoes
8. Improved pistons
9. Brass bushings
10. Hardened steel cylinder block
11. Bimetal distributor
12. Needle bearing
13. Solid end cover

The main advantages of the heavy duty design of the MAP motors over the typical swash plate motors are the higher starting torque and the higher total efficiency. In regards to these two parameters, under normal working mode, the MAP is comparable to the bent axis motors. The advantages of the MAP over the bent axis motors are the higher reliability and the lower degree of pulsation and vibration during operation.

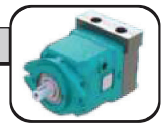

SPECIFICATION DATA

Type		MAP 35	MAP 40	MAP 46	MAP 50	MAP 52	MAP 58	MAP 62
Displacement, cm³/rev [in³/rev]		36.16 [2.21]	41.59 [2.54]	47.13 [2.88]	49.94 [3.05]	51.95 [3.17]	58.8 [3.59]	62.4 [3.81]
Max. Speed, [RPM]	Cont.	4000	4000	4000	3600	3850	3398	3050
	Int.*	4500	4500	4500	4200	4330	3823	3500
Max. Torque,** Nm [lb-in]	Cont.	202 [1789]	232 [2053]	263 [2328]	278 [2460]	290 [2566]	320 [2832]	318 [2814]
	Int.**	242 [2142]	278 [2460]	315 [2788]	326 [2885]	347 [3071]	375 [3320]	377 [3337]
Output, kW [HP]	Cont.	58 [78]	67 [90]	76 [102]	76 [102]	80 [107]	80 [107]	80 [107]
	Int.**	84 [113]	97 [130]	110 [148]	110 [148]	120 [161]	120 [161]	120 [161]
Max. Pressure, bar [PSI]	Cont.	350 [5080]	350 [5080]	350 [5080]	350 [5080]	350 [5080]	340 [4930]	320 [4640]
	Int.**	420 [6100]	420 [6100]	420 [6100]	410 [5950]	420 [6100]	400 [5800]	380 [5510]
	Peak	450 [6527]	450 [6527]	450 [6527]	450 [6527]	450 [6527]	440 [6381]	410 [5950]
Max. Oil Flow, l/min [GPM]	Cont.	145 [38.3]	167 [44.1]	189 [50]	180 [47.5]	200 [52.8]	200 [52.8]	190 [50]
	Int.*	163 [43.1]	187 [49.4]	212 [56]	210 [55.5]	225 [59.4]	225 [59.4]	215 [56.8]
Torque Constant *****		0.52	0.6	0.68	0.72	0.75	0.85	0.9
Nm/bar [lb-in/PSI]		[0.32]	[0.364]	[0.41]	[0.437]	[0.454]	[0.515]	[0.546]
Speed Constant *****		26.3	22.84	20.2	19.02	18.28	16.13	15.23
RPM/(l/min) [RPM/GPM]		[99.4]	[86.5]	[76.3]	[72]	[70.2]	[61.1]	[57.6]
Permissible Shaft Load		Fa=2000 [450]						
max Axial**** N[lb]		Fr=3600 [810]						
max Radial**** N[lb]		Fr=3600 [810]				Fr=3200 [720]		
Min. Speed, [RPM]		500						
Max. Pressure in Drain Line, bar [PSI]		5 [70] open drain line is always required						
Weight, kg [lb]		17.65 [38.9] for SAE-B flange; 19.8 [43.7] for SAE-4C flange						

Peak pressure is the highest allowable pressure, may occur for max. 1% of every minute;

* Intermittent speed (flow): for pressure up to 150[2200] bar[PSI];

** Intermittent load: the permissible values may occur for max. 10% of motor lifetime;

*** Theoretical torque;

**** The calculated max values are based on the optimal direction of the forces Fr, Fa and optimal position of the shaft.

***** The constant values are used for calculation of torque and speed with motor efficiencies $\eta_v=0.95$ and $\eta_{mh}=0.9$.

1. The recommended output power for continuous operations should not be exceeded.
2. Recommended filtration as per ISO 4406 cleanliness code 18/16/13 or better. This filtration corresponds to SAE AS 4059 8A/7B/7C. Nominal filtration - 10 micron or better.
3. Recommended a premium quality, anti-wear type mineral based hydraulic oil, HLP(DIN51524) or HM(ISO6743/4).
4. Recommended oil viscosity - 12...68 cSt or see page 84.
5. Recommended maximum system operating temperature - 82°[180°] C[F].
6. To ensure optimum life of the motor, fill it up with fluid prior to load it and run with moderate load and speed for about 10-15 minutes.

Hint: Motor Torque = Torque Constant * Pressure Drop

Rotation Speed = Speed Constant * Oil Flow

The constant values are approximate. Motor torque and rotation speed for a particular project are depending on the real operating conditions. For more detailed calculations please see efficiencies on page 74 and formulas on page 85.

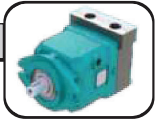

OVERALL DIMENSIONS AND PORTS

Side Ports - Default Mounting Flange - Type SAE-B

Standard Rotation
Viewed from shaft end
Port A Pressurized - CW
Port B Pressurized - CCW
see page 81

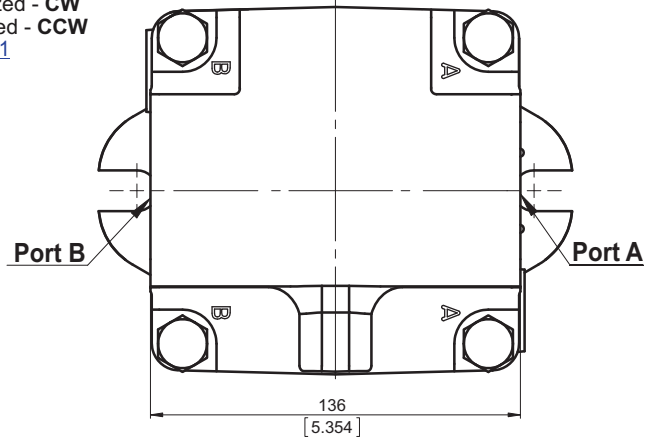
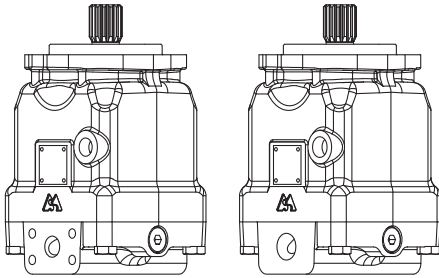

Side ports, port size default, 5 and 9

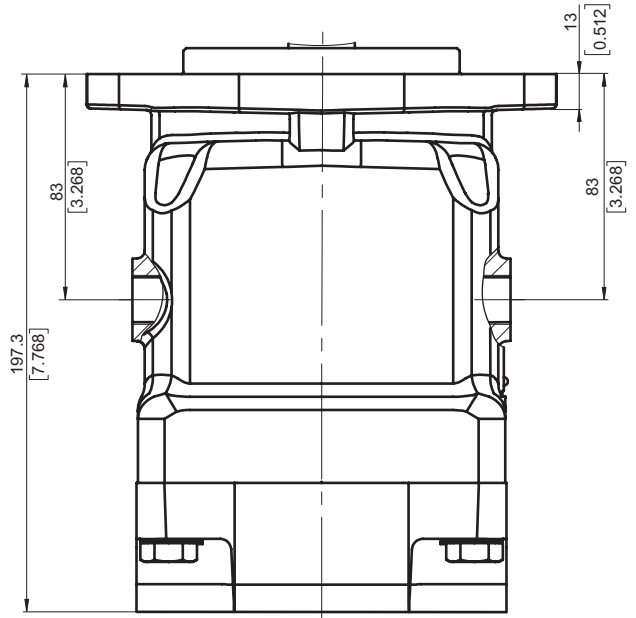
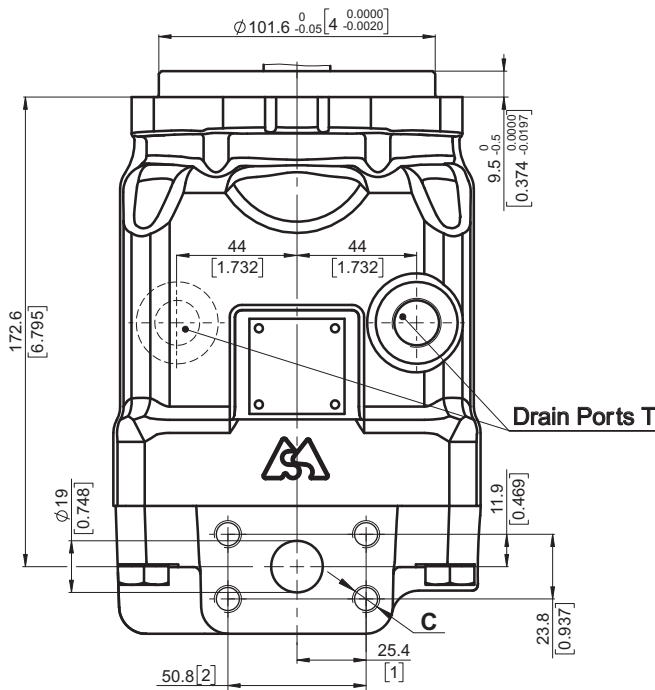

	Port Size		
	default	5	9
P _(A,B)	2xISO 6162-2 DN19	2xSAE J518 3/4" PSI6000	2xISO 6162-2 DN19
T	M18x1.5	7/8-14 UNF	G1/2
C	8xM10	8x3/8-16 UNC	8xM10

Side ports, port size 2,3 and 4

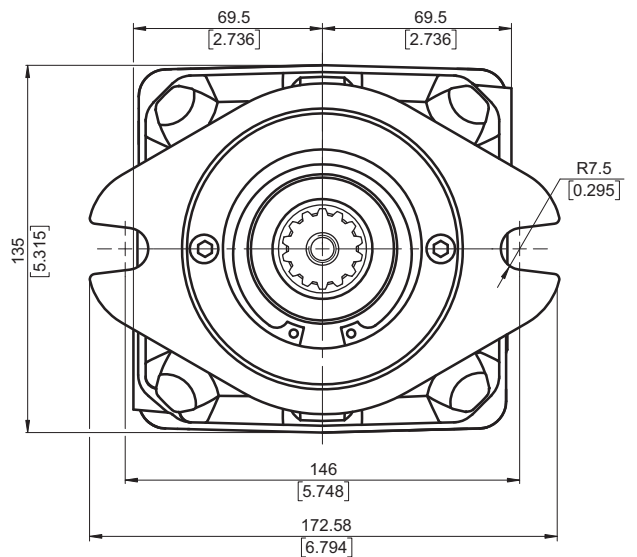
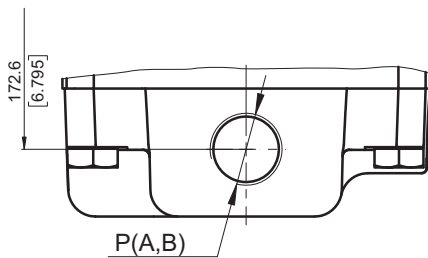

	Port Size		
	2	3	4
P _(A,B)	2xG 3/4	2xM27x2	2x1 1/16-12UN
T	G 1/2	M18x1.5	7/8-14UNF

Shaft Mounting see page 26

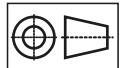

mm [in]

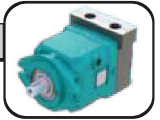

OVERALL DIMENSIONS AND PORTS

Rear Ports - Type E Mounting Flange - Type SAE-B

Standard Rotation
Viewed from shaft end
Port A Pressurized - CW
Port B Pressurized - CCW
see page 81

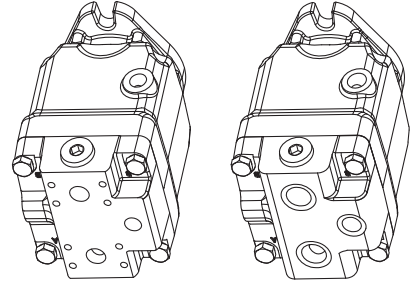

Rear ports E, port size default, 5 and 9

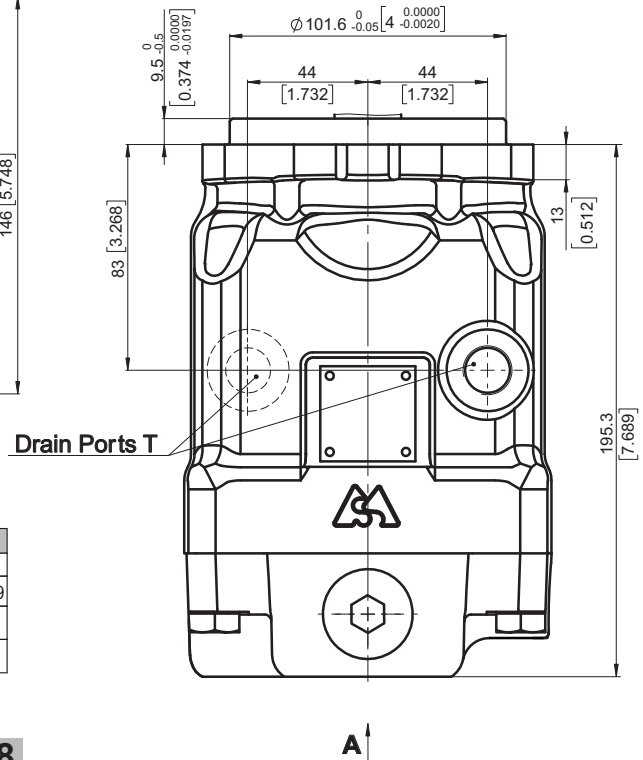
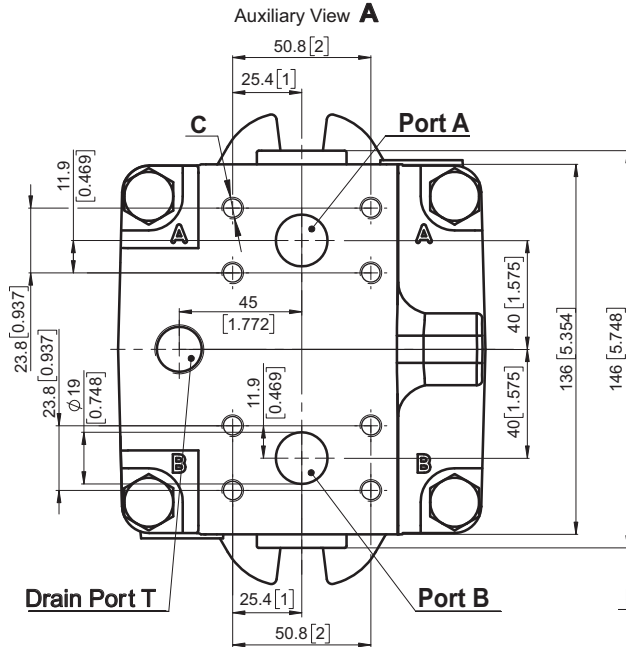

	Port Size		
	default	5	9
P _(A,B)	2xISO 6162-2 DN19	2xSAE J518 3/4" PSI6000	2xISO 6162-2 DN19
T	M18x1.5	7/8-14 UNF	G1/2
C	8xM10	8x3/8-16 UNC	8xM10

Rear ports E, port size 2,3,4,6,7 and 8

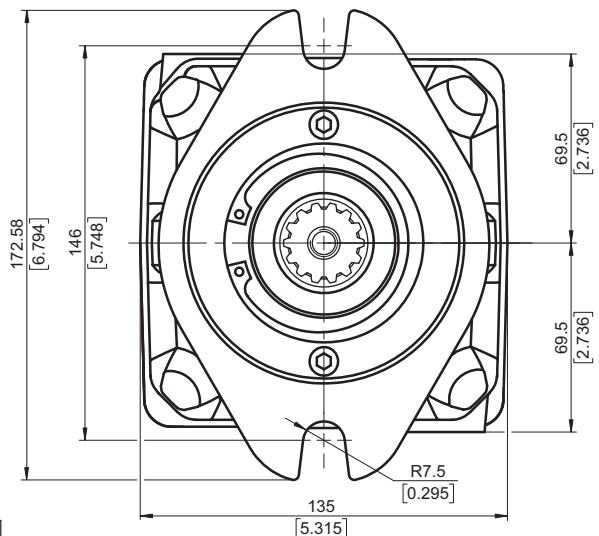
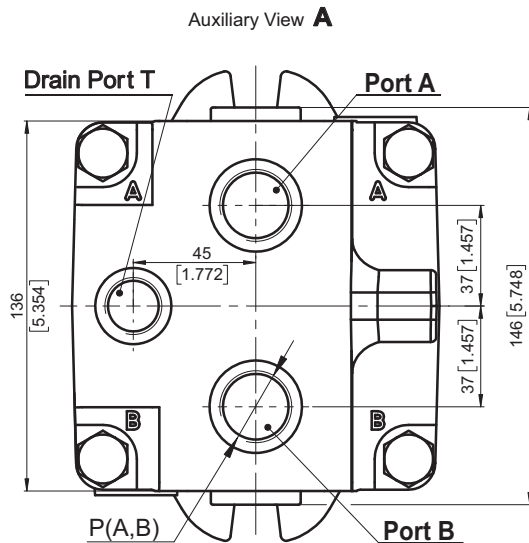

	Port Size					
	2	3	4	6	7	8
P _(A,B)	2xG 3/4	2xM27x2	2x1 1/16-12UN	2xG 1/2	2xM22x1.5	2x7/8-14UNF
T	G 1/2	M18x1.5	7/8-14UNF	G 1/2	M18x1.5	3/4-16UNF

Shaft Mounting
see page 26

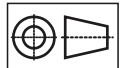

mm [in]

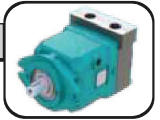

OVERALL DIMENSIONS AND PORTS

Standard Rotation
Viewed from shaft end
Port A Pressurized - CW
Port B Pressurized - CCW
see page 81

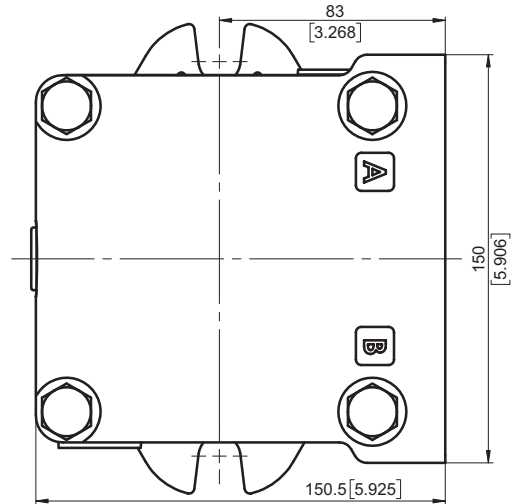
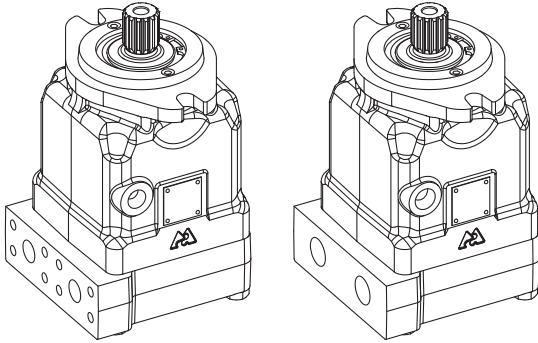

Twin side ports, port size default, 5 and 9

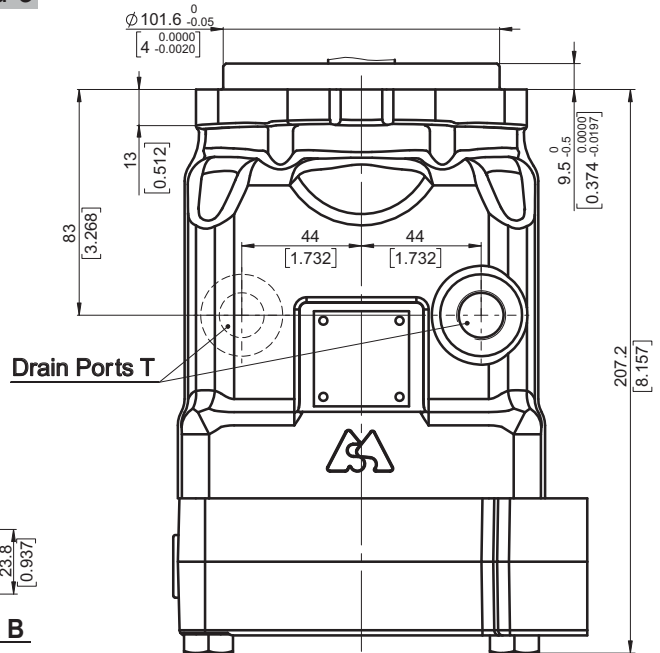
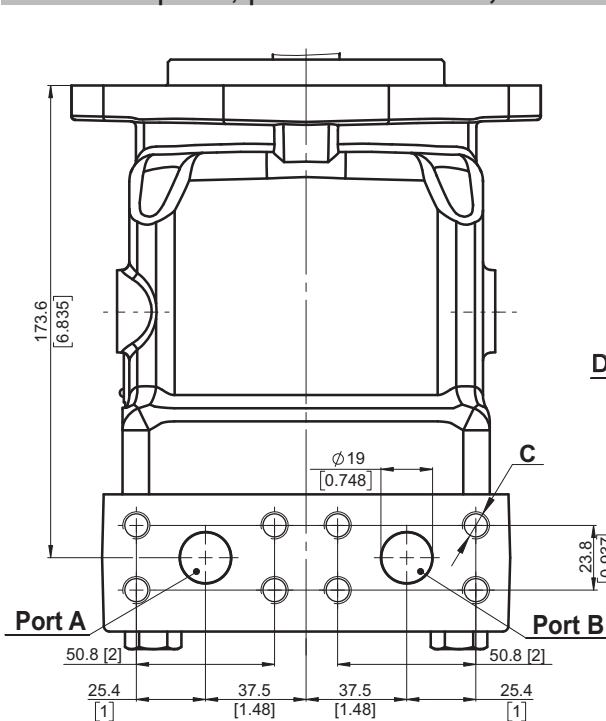

	Port Size		
	default	5	9
P _{A,B}	2xISO 6162-2 DN19	2xSAE J518 3/4" PSI6000	2xISO 6162-2 DN19
T	M18x1.5	7/8-14 UNF	G1/2
C	8xM10	8x3/8-16 UNC	8xM10

Twin side ports, port size 2,3,4,6,7 and 8

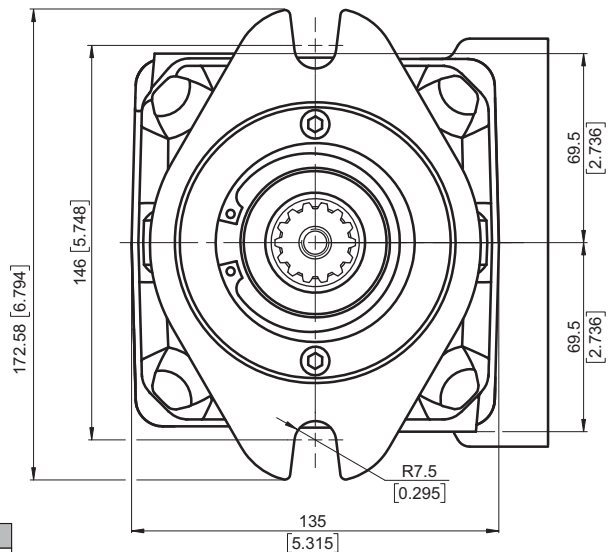
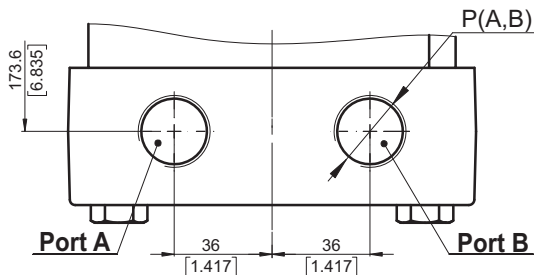

	Port Size					
	2	3	4	6	7	8
P _{A,B}	2xG 3/4	2xM27x2	2x1 1/16-12UN	2xG 1/2	2xM22x1.5	2x7/8-14UNF
T	G 1/2	M18x1.5	7/8-14UNF	G 1/2	M18x1.5	3/4-16UNF

Shaft Mounting
see next page

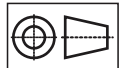

mm [in]

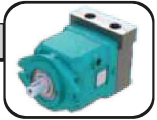

SHAFTS MOUNTING

Mounting Flange - Type SAE-B

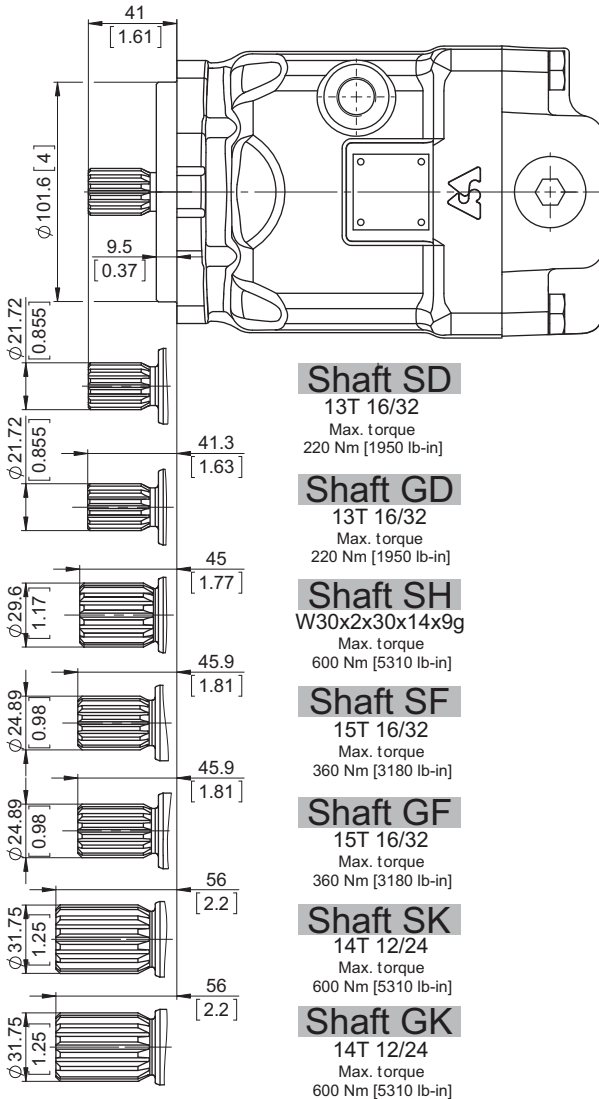

Shaft SD

13T 16/32
Max. torque
220 Nm [1950 lb-in]

Shaft GD

13T 16/32
Max. torque
220 Nm [1950 lb-in]

Shaft SH

W30x2x30x14x9g
Max. torque
600 Nm [5310 lb-in]

Shaft SF

15T 16/32
Max. torque
360 Nm [3180 lb-in]

Shaft GF

15T 16/32
Max. torque
360 Nm [3180 lb-in]

Shaft SK

14T 12/24
Max. torque
600 Nm [5310 lb-in]

Shaft GK

14T 12/24
Max. torque
600 Nm [5310 lb-in]

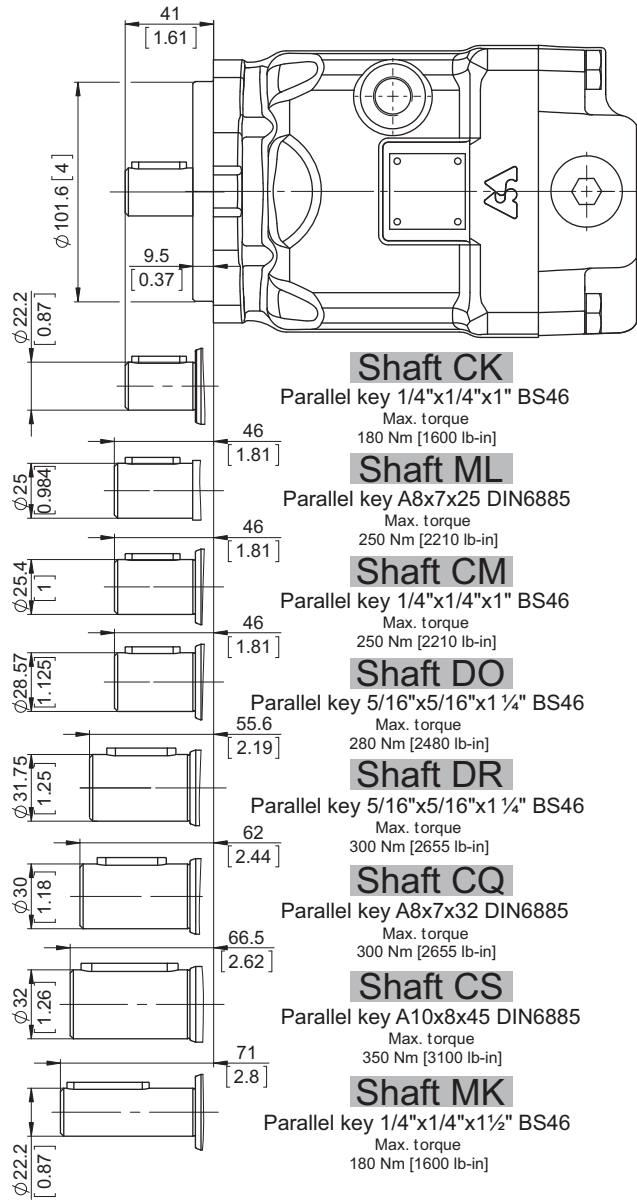

Shaft CK

Parallel key 1/4"x1/4"x1" BS46
Max. torque
180 Nm [1600 lb-in]

Shaft ML

Parallel key A8x7x25 DIN6885
Max. torque
250 Nm [2210 lb-in]

Shaft CM

Parallel key 1/4"x1/4"x1" BS46
Max. torque
250 Nm [2210 lb-in]

Shaft DO

Parallel key 5/16"x5/16"x1 1/4" BS46
Max. torque
280 Nm [2480 lb-in]

Shaft DR

Parallel key 5/16"x5/16"x1 1/4" BS46
Max. torque
300 Nm [2655 lb-in]

Shaft CQ

Parallel key A8x7x32 DIN6885
Max. torque
300 Nm [2655 lb-in]

Shaft CS

Parallel key A10x8x45 DIN6885
Max. torque
350 Nm [3100 lb-in]

Shaft MK

Parallel key 1/4"x1/4"x1 1/2" BS46
Max. torque
180 Nm [1600 lb-in]

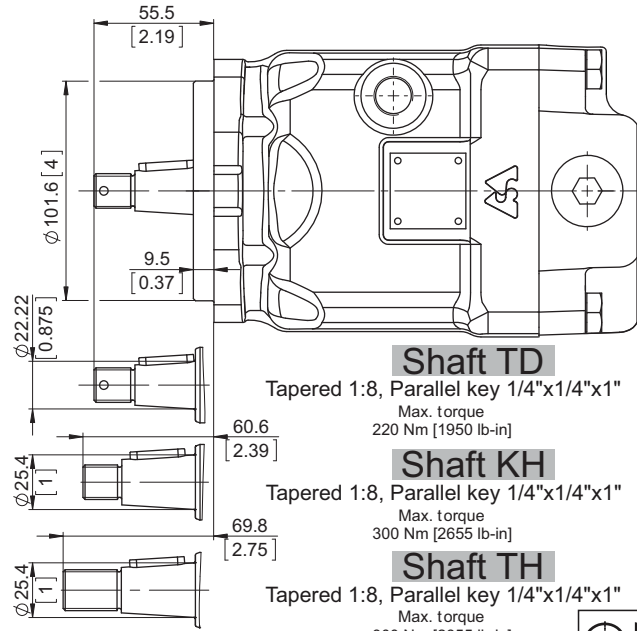

Shaft TD

Tapered 1:8, Parallel key 1/4"x1/4"x1"
Max. torque
220 Nm [1950 lb-in]

Shaft KH

Tapered 1:8, Parallel key 1/4"x1/4"x1"
Max. torque
300 Nm [2655 lb-in]

Shaft TH

Tapered 1:8, Parallel key 1/4"x1/4"x1"
Max. torque
300 Nm [2655 lb-in]

Shaft Dimensions
See Page 69+73

PERMISSIBLE SHAFT LOAD

Permissible shaft load		
max Axial	N[lb]	Fa=2000 [450]
max Radial	N[lb]	Fr=3600 [810]

The calculated max values are based on the optimal direction of the forces Fr, Fa and optimal position of the shaft (see page 81).

For more information, please, feel free to contact us.

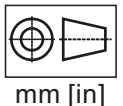

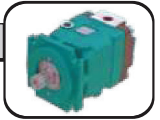

OVERALL DIMENSIONS AND PORTS

Side Ports - Default Mounting Flange Type - SAE 4C and 4L

Standard Rotation
Viewed from shaft end
Port A Pressurized - CW
Port B Pressurized - CCW
see page 81

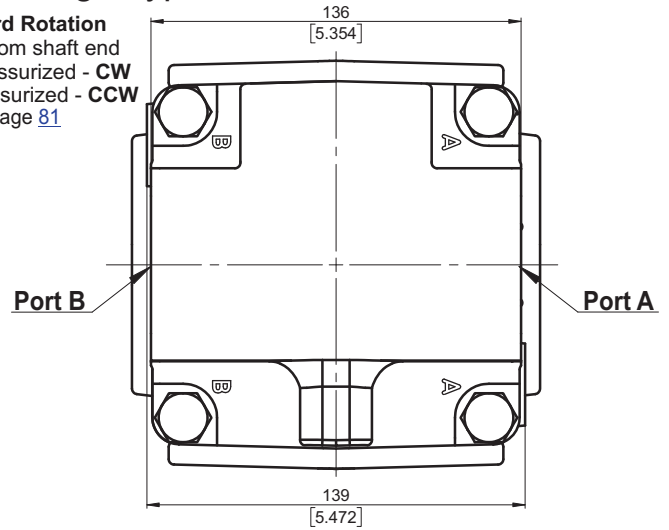
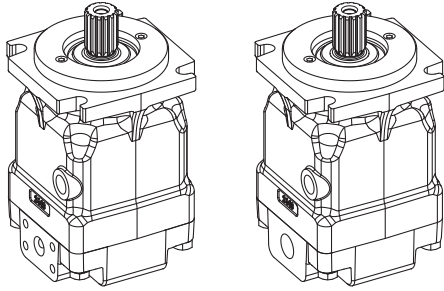

Side ports, port size default, 5 and 9

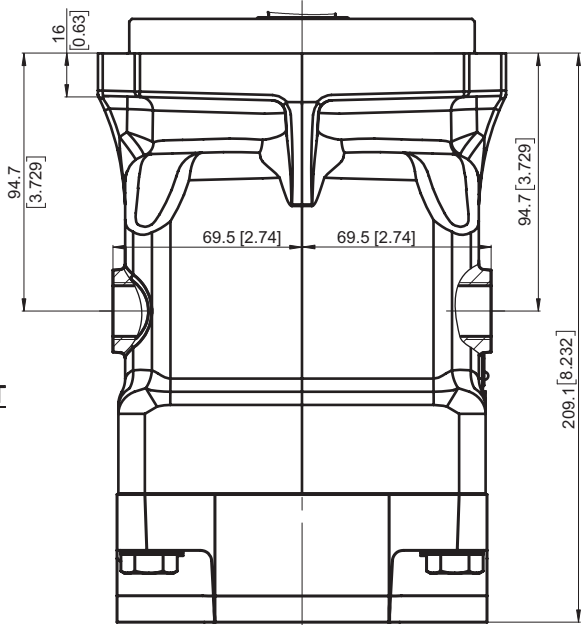
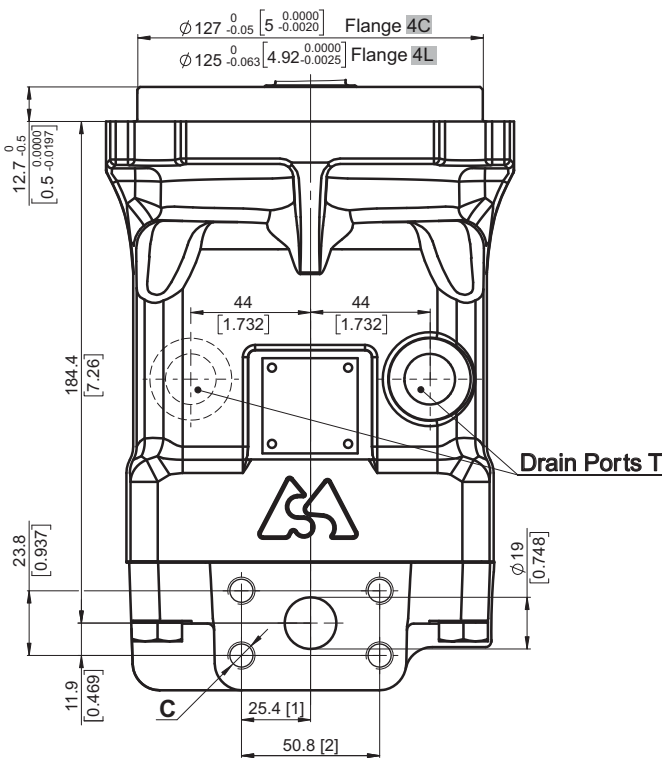

	Port Size		
	default	5	9
P _(A,B)	2xISO 6162-2 DN19	2xSAE J518 3/4" PSI6000	2xISO 6162-2 DN19
T	M18x1.5	7/8-14 UNF	G1/2
C	8xM10	8x3/8-16 UNC	8xM10

Side ports, port size 2,3 and 4

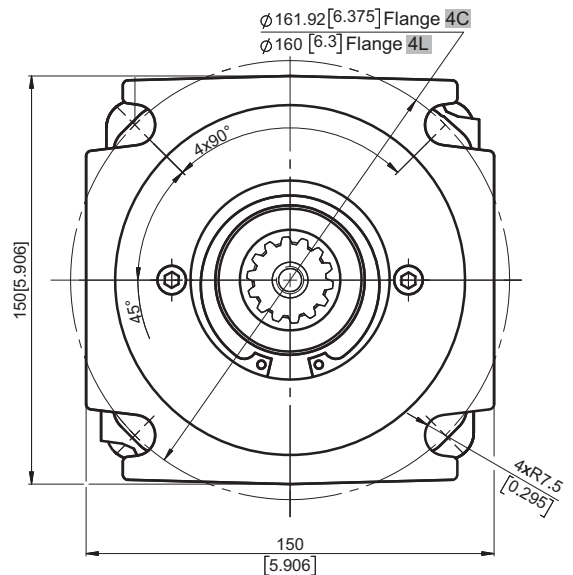
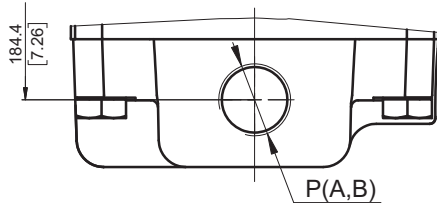

	Port Size		
	2	3	4
P _(A,B)	2xG 3/4	2xM27x2	2x1 1/16-12UN
T	G 1/2	M18x1.5	7/8-14UNF

Shaft Mounting
see page 30

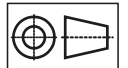

mm [in]

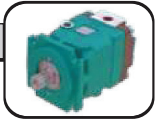

OVERALL DIMENSIONS AND PORTS

Rear Ports - Type E Mounting Flange Type - SAE 4C and 4L

Standard Rotation
Viewed from shaft end
Port A Pressurized - CW
Port B Pressurized - CCW
see page 81

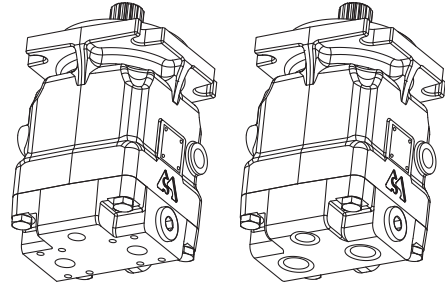

Rear ports, port size default, 5 and 9

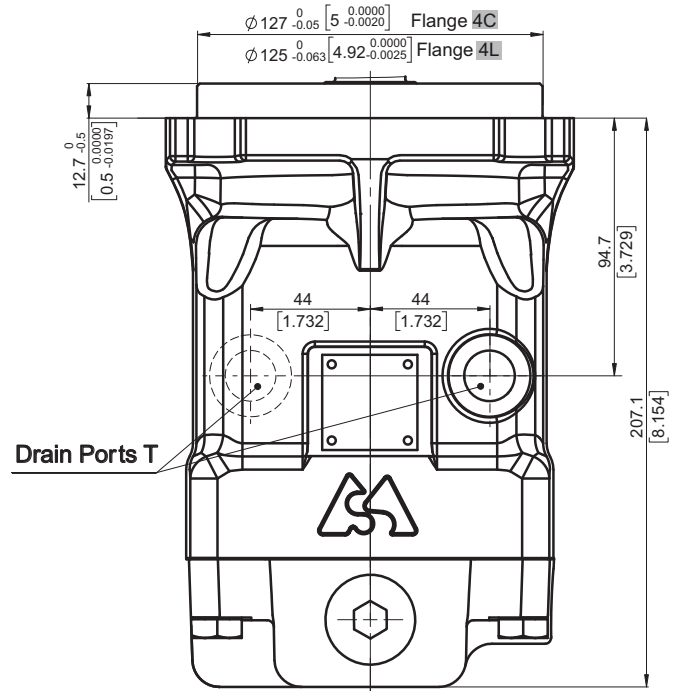
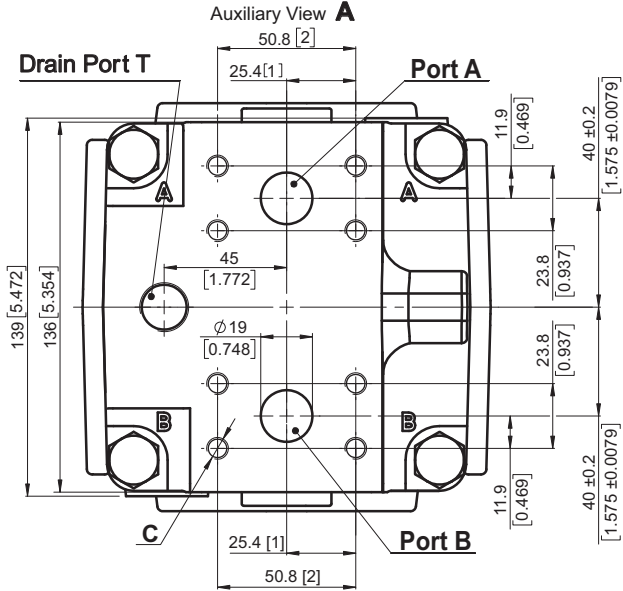

	Port Size		
	default	5	9
P _(A,B)	2xISO 6162-2 DN19	2xSAE J518 3/4" PSI6000	2xISO 6162-2 DN19
T	M18x1.5	7/8-14 UNF	G1/2
C	8xM10	8x3/8-16 UNC	8xM10

Rear ports, port size 2,3,4,6,7 and 8

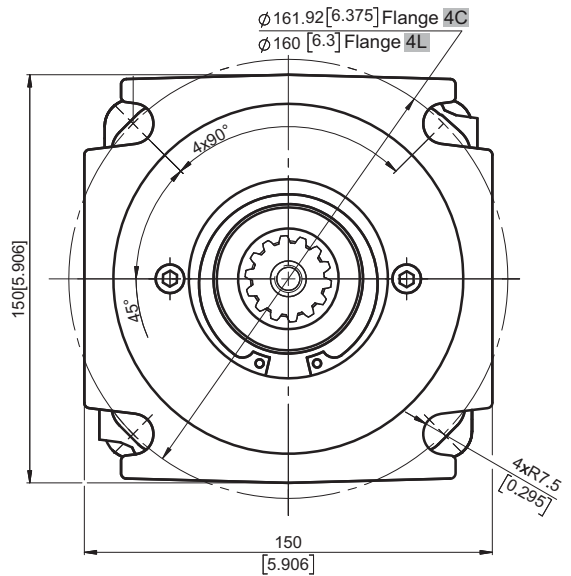
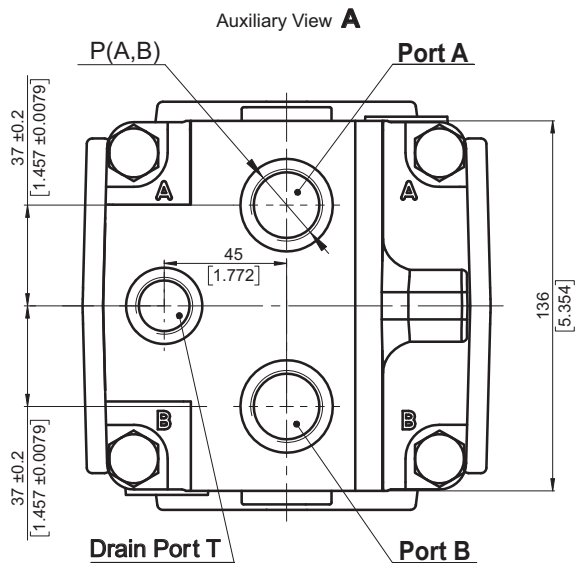

	Port Size						
	2	3	4	6	7	8	
P _(A,B)	2xG 3/4	2xM27x2	2x1 1/16-12UN	2xG 1/2	2xM22x1.5	2x7/8-14UNF	
T	G 1/2	M18x1.5	7/8-14UNF	G 1/2	M18x1.5	3/4-16UNF	

Shaft Mounting
see page 30

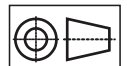

mm [in]

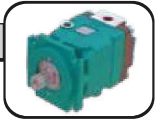

OVERALL DIMENSIONS AND PORTS

Twin Ports - Type T Mounting Flange Type - SAE 4C and 4L

Standard Rotation
Viewed from shaft end
Port A Pressurized - CW
Port B Pressurized - CCW
see page 81

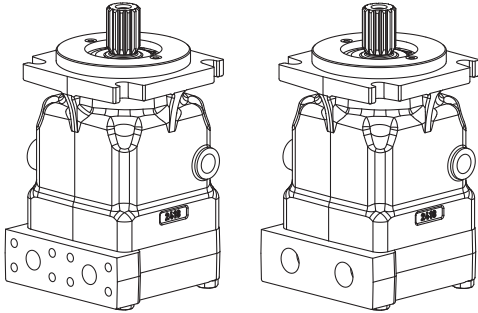

Twin ports, port size default, 5 and 9

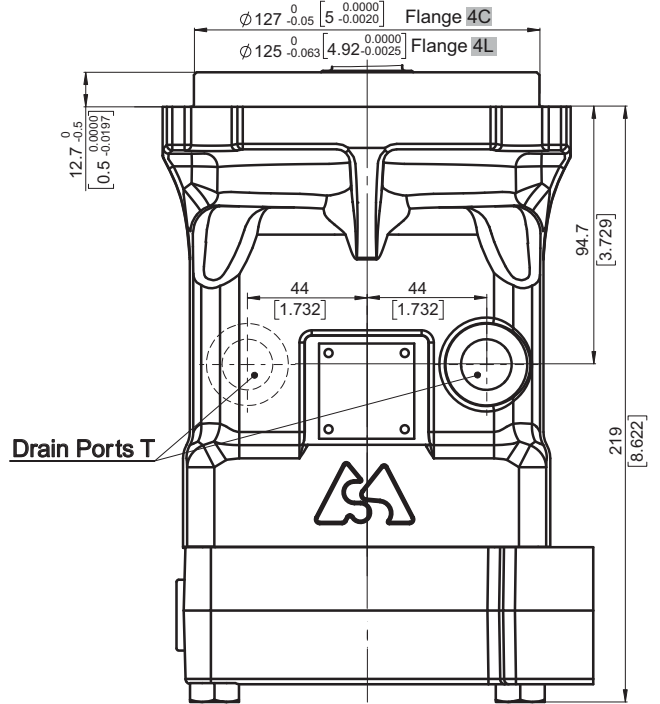
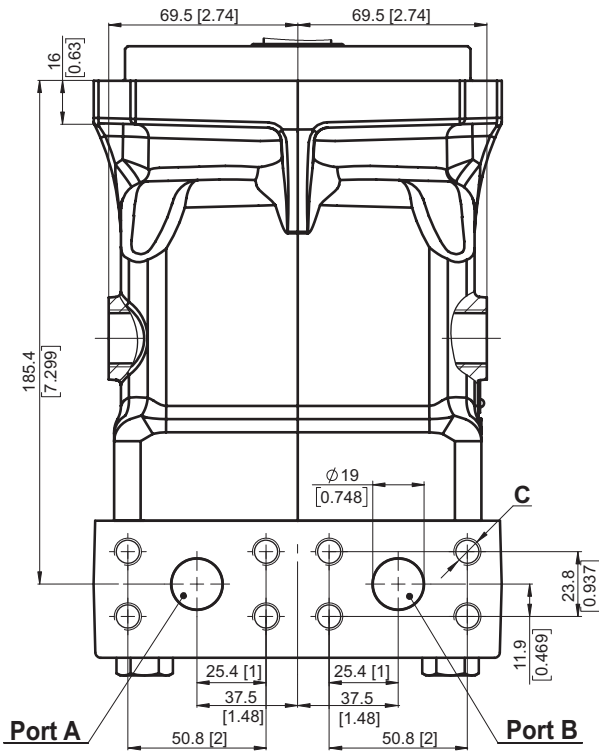
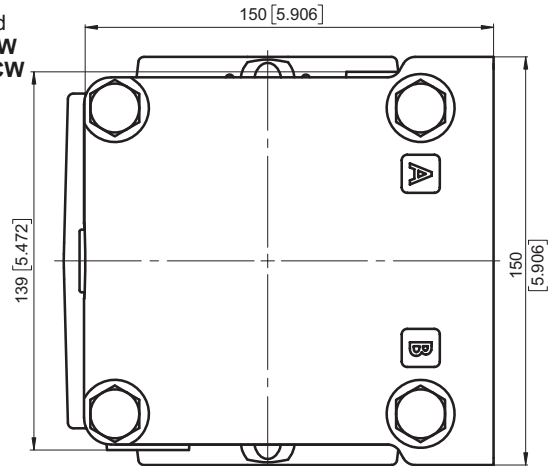

	Port Size		
	default	5	9
P _(A,B)	2xISO 6162-2 DN19	2xSAE J518 3/4" PSI6000	2xISO 6162-2 DN19
T	M18x1.5	7/8-14 UNF	G1/2
C	8xM10	8x3/8-16 UNC	8xM10

Twin ports, port size 2,3,4,6,7 and 8

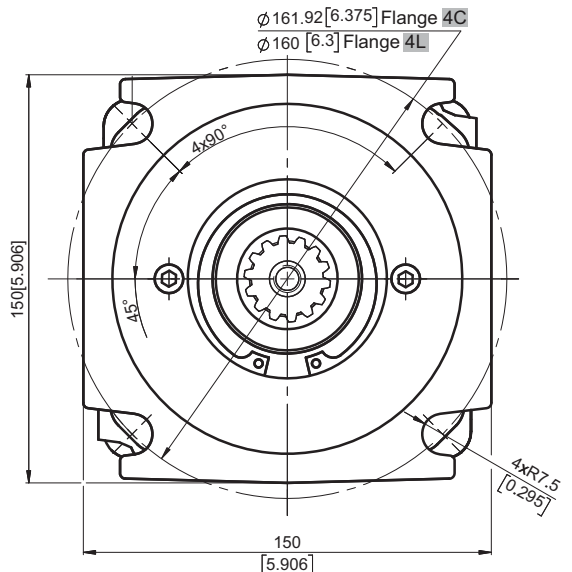
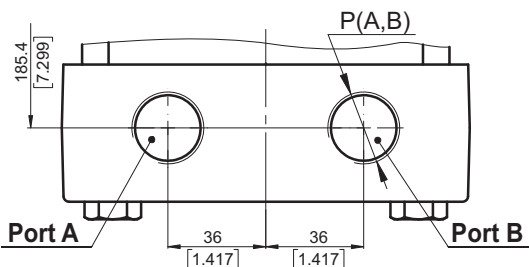

	Port Size					
	2	3	4	6	7	8
P _(A,B)	2xG 3/4	2xM27x2	2x1 1/16-12UN	2xG 1/2	2xM22x1.5	2x7/8-14UNF
T	G 1/2	M18x1.5	7/8-14UNF	G 1/2	M18x1.5	3/4-16UNF

Shaft Mounting
see page 30

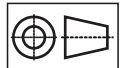

mm [in]



SHAFTS MOUNTING

Mounting Flange - Type - SAE 4C and 4L

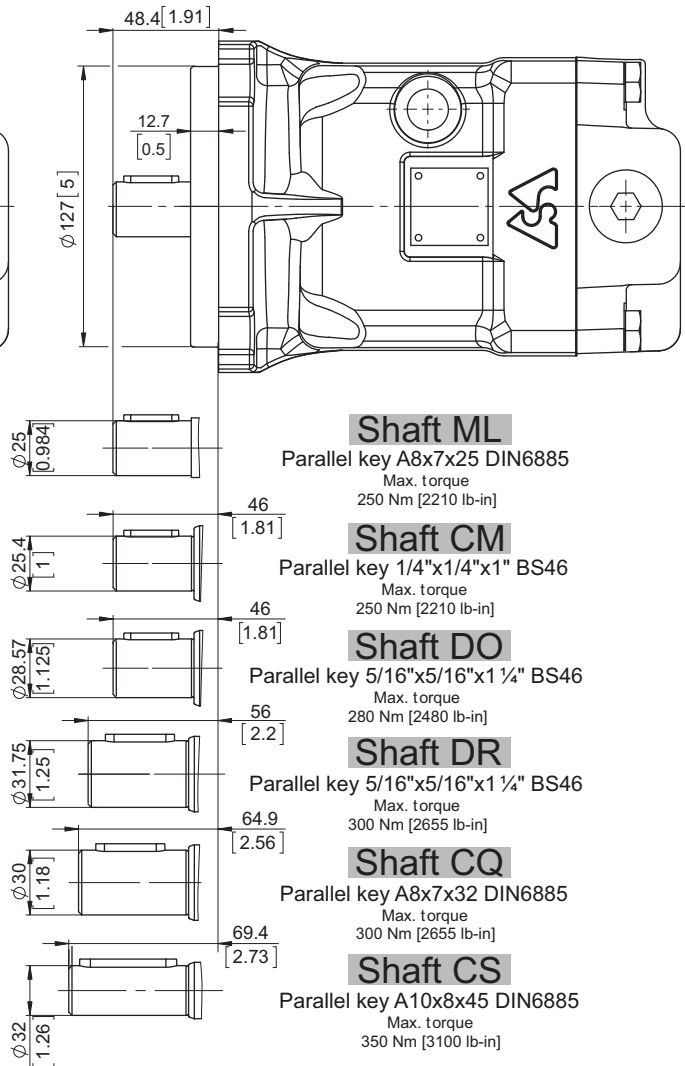
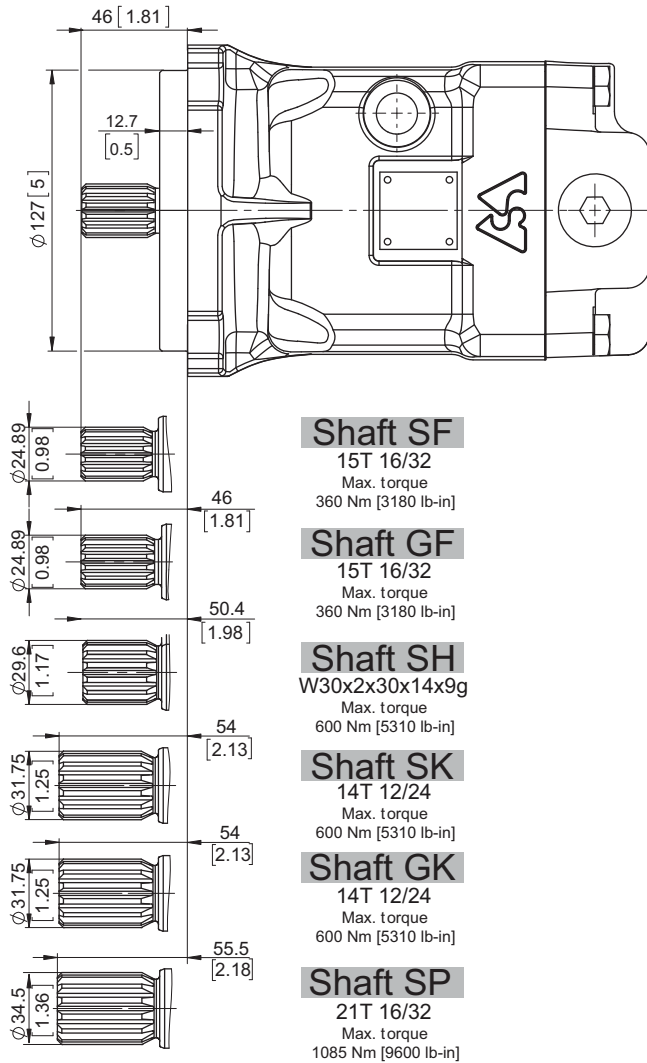

Shaft Dimensions
See Page 69+73

PERMISSIBLE SHAFT LOAD

Permissible shaft load		
max Axial	N[lb]	Fa=2000 [450]
max Radial	N[lb]	Fr=3200 [720]

The calculated max values are based on the optimal direction of the forces Fr, Fa and optimal position of the shaft (see page 81).

For more information, please, feel free to contact us.

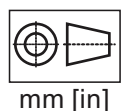

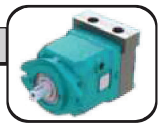

ORDERING CODE

	1	2	3	4	5	6	7	8	9	10	11	12	13	13	13
M A P													[]

Pos.1 - Mounting Flange

- B** - SAE B - 2-Bolt flange
spigot diam. 101.6 [4"] - BC 146 [5.75"]
- 4L** - 4-Bolt flange spigot diam. 125 [4.92"] - BC 160 [6.3"]
- 4C** - SAE C - 4-Bolt flange
spigot diam. 127 [5"] - BC 161.92 [6.375"]

Pos.2 - Port Type

- omit - Side ports on opposite sides
- T** - Twin (Two) side ports on one side
- E** - Rear ports

Pos.3 - Displacement Code

- 35** - 36.16 cm³/rev [2.21 in³/rev]
- 40** - 41.59 cm³/rev [2.54 in³/rev]
- 46** - 47.13 cm³/rev [2.88 in³/rev]
- 50** - 49.94 cm³/rev [3.05 in³/rev]
- 52** - 51.95 cm³/rev [3.17 in³/rev]
- 58** - 58.8 cm³/rev [3.59 in³/rev]
- 62** - 62.4 cm³/rev [3.81 in³/rev]

Pos.4 - Shaft Extensions**

- SD** - ø21.72 [0.855"] Spline SAE 13T 16/32 DP, M8
 - GD** - ø21.72 [0.855"] Spline SAE 13T 16/32 DP,
5/16-18 UNC thread
 - SF** - ø24.9 [0.98"] Spline SAE 15T 16/32, M8
 - GF** - ø24.9 [0.98"] Spline SAE 15T 16/32, 3/8-16UNC
 - SH** - ø29.6 [1.165"] Spline W30x2x30x14x9g, M10
 - SK** - ø31.75 [1.25"] Spline SAE 14T 12/24 DP, M10
 - GK** - ø31.75 [1.25"] Spline SAE 14T 12/24 DP,
7/16-14UNC thread
 - SP** - ø34.5 [1.358"] Spline SAE 21T 16/32 DP, M12
 - CK** - ø22.2 [7/8"] Straight, M8 thread
Parallel key 1/4"x1/4"x1" BS46
 - MK** - ø22.2 [7/8"] Straight, M8 thread
Parallel key 1/4"x1/4"x1 1/2" BS46
 - ML** - ø25 [0.984"] Straight, M8 thread
Parallel key A8x7x25 DIN6885
 - CM** - ø25.4 [1"] Straight, M8 thread
Parallel key 1/4"x1/4"x1" BS46
 - DO** - ø28.75 [1.125"] Straight, 3/8-16UNC
Parallel key 5/16"x5/16"x1 1/4" BS46
 - CQ** - ø30 [1.181"] Straight, M8 thread
Parallel key A8x7x32 DIN6885
 - DR** - ø31.75 [1.25"] Straight, 3/8-16UNC
Parallel key 5/16"x5/16"x1 1/4" BS46
 - CS** - ø32 [1.26"] Straight, M8 thread
Parallel key A10x8x45 DIN6885
 - TD** - ø22.22 [7/8"] Tapered 1:8 [125:1000],
Parallel key 1/4"x1/4"x1", 5/8-18 UNF
 - TH** - ø25.4 [1"] Tapered 1:8 [125:1000],
Parallel key 1/4"x1/4"x1", 3/4-16 UNF
 - KH** - ø25.4 [1"] Tapered 1:8 [125:1000],
Parallel key 1/4"x1/4"x1", M16x1.5
- Shaft type SP is available only for Pos.1 option 4C and 4L

Pos.5 - Port Size

- omit - 2xISO 6162-2 DN19, drain port M18x1.5
 - 2** - 2xG3/4, drain ports G1/2
 - 3** - 2xM27x2, drain ports M18x1.5
 - 4** - 2x1 1/16 -12 UN, drain ports 7/8-14 UNF
 - 5** - 2xSAE 3/4" PSI6000, drain port 7/8-14 UNF
 - 6** - 2xG1/2, drain ports G1/2
 - 7** - 2xM22x1.5, drain ports M18x1.5
 - 8** - 2x7/8-14 UNF Ports, drain ports 3/4-16 UNF
 - 9** - 2xISO 6162-2 DN19, drain port G1/2
- Option 6;7 and 8 are not available for Pos.2 option omit

Pos.6 - Seal, Corrosion Resistant Seal Surface

- omit - NBR seal type material
- V** - FKM seal type material

Pos.7 - Integrated Valves

- See page 77÷78 for information about valves
- omit - None
 - HR** - Single anti-cavitation valve
 - AR** - Dual anti-cavitation valve
 - PU** - Purge valve - default - 6±2 l/min
 - FLU** - Flush valve - default - 6±2 l/min at 20 bar
 - SAR** - Single anti-cavitation and relief valve
 - DAR** - Dual anti-cavitation and relief valve
 - DARP** - Dual anti-cavitation, relief and purge
valve, default flow - 6±2 l/min
 - DARF** - Dual anti-cavitation, relief and flush
valve, default flow - 6±2 l/min at 20 bar

Option DAR,DARF,DARP,SAR, AR and HR are not available for Pos.2 option E
Option DARF and DARP are not available for Pos.2 option omit

Pos.8 - Valve's Port for Single Valves

- omit - None
- A** - Port A
- B** - Port B

Pos.9 - Pressure Setting of Integrated Valves

- omit - None
 - x** -

250	300	350
-----	-----	-----
- for more information see page 77÷78

Pos.10 - Flow Setting of Integrated Valves

- omit - None
- Lx** - For value - see page 77÷78

Pos.11 - Special Features*

- omit - None
- R2S** - Speed Sensor Two Directional (see page 79)
- R** - Reverse Rotation (see page 81)

Pos.12 - Paint and Coating

- omit - No paint or coating
- P** - Painted
- PC** - Corrosion protected paint

If a painting option is required, the standard color is black-Alkyd-Styrenated Enamel, Black RAL 9005.
Other color by customer's request.

Pos.13 - Design Series

- omit - Factory specified
- **The permissible output torque for shafts must not be exceeded!

EXAMPLE

M A P B E 4 0 G D 4 P

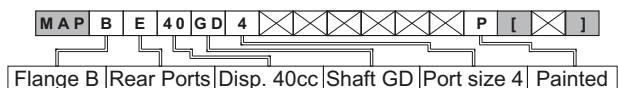

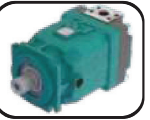

Hydraulic Motors Type MAP100

Heavy Duty Axial Piston Motors Fixed Displacement

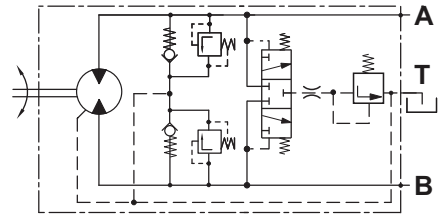
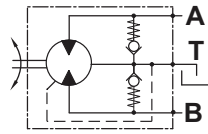
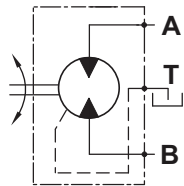

open drain line is always required

APPLICATION

- » Agricultural machines
- » Road building machines
- » Mining machinery
- » Food industry machines
- » Swing drives
- » Hydraulic transmissions
- » Vibration machines
- » Fan drives
- » Special vehicles

OPTIONS

- » Flange options
- » Port options
- » Shaft options
- » High pressure ports
- » Integrated valves

ADVANTAGES

- » High starting torque
- » Smooth operation
- » Long service life
- » High power density

GENERAL

Displacement,	cm ³ /rev [in ³ /rev]	63.58÷98.75 [3.88÷6.03]
Max. Speed,	RPM	3500
Max. Torque,	Nm [lb-in]	550 [4870]
Max. Output,	kW [HP]	130 [174]
Max. Pressure Drop,	bar [PSI]	350 [5080]
Max. Oil Flow,	l/min [GPM]	326 [86.1]
Min. Speed,	RPM	500
Fluid	Mineral based- HLP(DIN 51524) or HM(ISO 6743/4)	
Temperature Range,	°C [°F]	-40÷82 [-40÷180]
Optimal Viscosity Range,	mm ² /s [SUS]	12÷68 [66÷311]
Filtration	ISO code 18/16/13 (Min. recommended fluid filtration of 10 micron)	

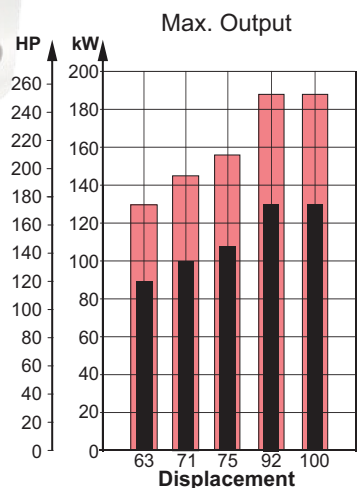
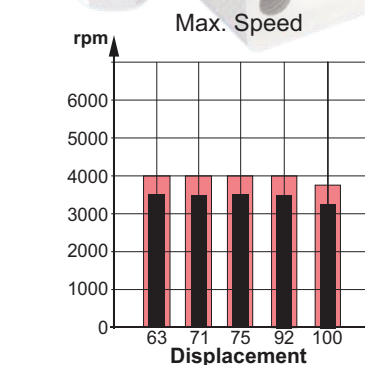
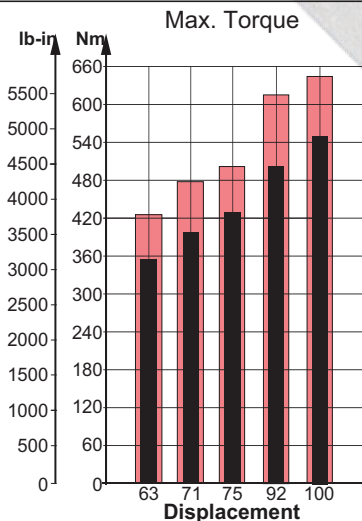



SECTION VIEW

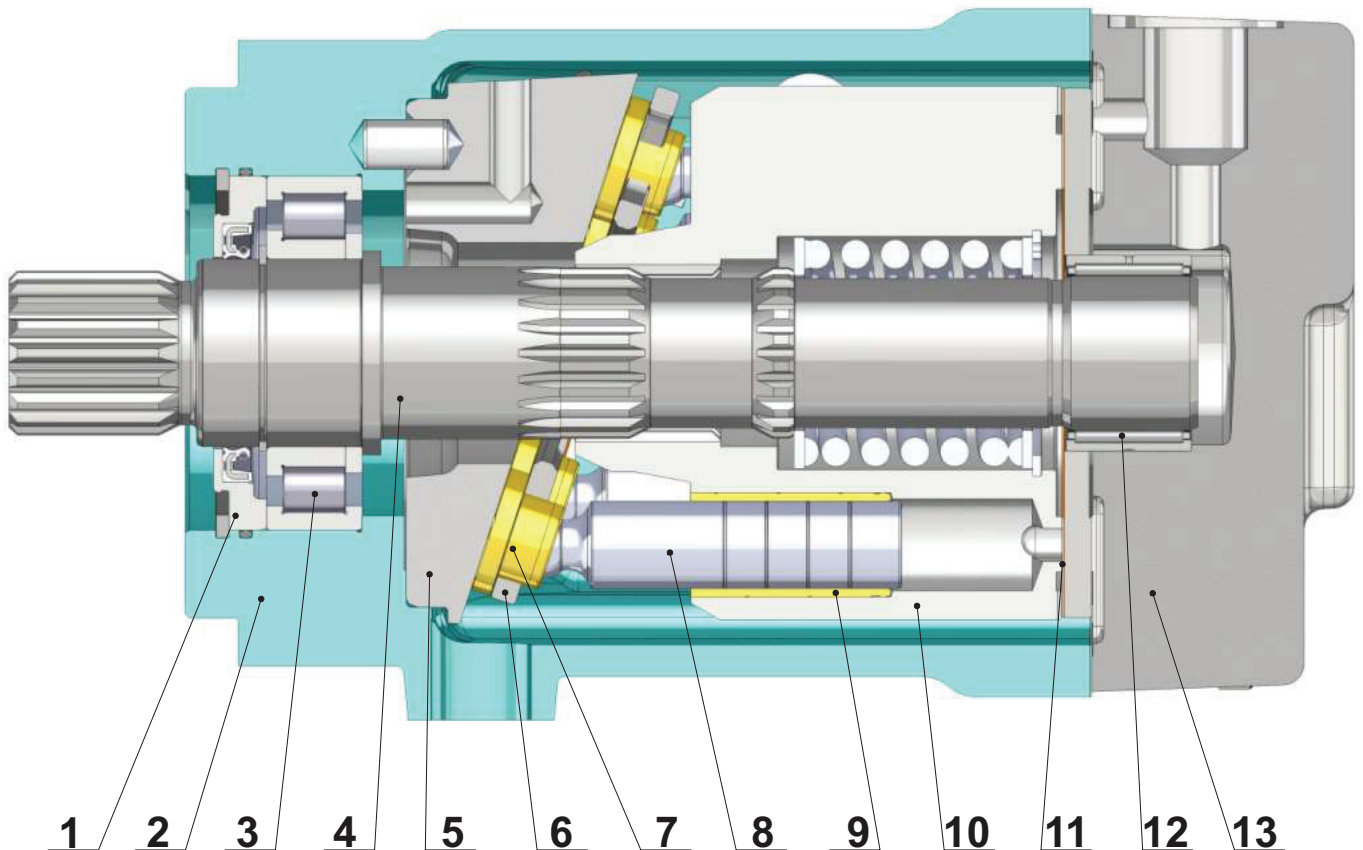

1. Front cover
2. Cast iron body
3. Robust radial - axial roller bearing
4. Hardened shaft
5. Solid swash plate
6. Retainer plate
7. Improved piston shoes
8. Improved pistons
9. Brass bushings
10. Hardened steel cylinder block
11. Bimetal distributor
12. Needle bearing
13. Solid end cover

The main advantages of the heavy duty design of the MAP motors over the typical swash plate motors are the higher starting torque and the higher total efficiency. In regards to these two parameters, under normal working mode, the MAP is comparable to the bent axis motors. The advantages of the MAP over the bent axis motors are the higher reliability and the lower degree of pulsation and vibration during operation.

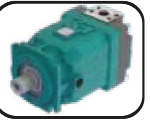
SPECIFICATION DATA

Type		MAP 63	MAP 71	MAP 75	MAP 92	MAP 100
Displacement, cm³/rev [in³/rev]		63.58 [3.88]	71.5 [4.36]	76.84 [4.69]	93.18 [5.69]	98.75 [6.03]
Max. Speed, [RPM]	Cont.	3500	3500	3500	3500	3240
	Int.*	4000	4000	4000	4000	3750
Max. Torque,*** Nm [lb-in]	Cont.	354 [3133]	398 [3523]	428 [3788]	514 [4549]	550 [4870]
	Int.**	425 [3762]	478 [4230]	514 [4549]	616 [5452]	645 [5710]
Output, kW [HP]	Cont.	89 [120]	100 [134]	108 [145]	130 [174]	130 [174]
	Int.**	129 [173]	145 [195]	156 [209]	188 [252]	188 [252]
Max. Pressure, bar [PSI]	Cont.	350 [5080]	350 [5080]	350 [5080]	350 [5080]	350 [5080]
	Int.**	420 [6100]	420 [6100]	420 [6100]	420 [6100]	410 [5950]
	Peak	450 [6527]	450 [6527]	450 [6527]	450 [6527]	450 [6527]
Max. Oil Flow, l/min [GPM]	Cont.	223 [58.9]	250 [66]	269 [71.1]	326 [86.1]	320 [84.5]
	Int.*	255 [67.4]	286 [75.6]	308 [81.4]	373 [98.5]	370 [97.7]
Torque Constant Nm/bar [lb-in/PSI]	*****	0.91 [0.56]	1.03 [0.63]	1.1 [0.67]	1.32 [0.81]	1.42 [0.87]
Speed Constants RPM/(l/min) [RPM/GPM]	*****	14.94 [56.56]	13.3 [50.3]	12.36 [46.8]	10.2 [38.6]	9.62 [36.42]
Permissible Shaft Load						
max Axial**** N[lb]		Fa=2500 [562]				
max Radial**** N[lb]		Fr=4500 [1010]				
Min. Speed, [RPM]		500				
Max. Pressure in Drain Line, bar [PSI]		5 [70] open drain line is always required				
Weight, kg [lb]		34.3 [75.62] for SAE-4C flange; 35.3 [77.82] for SAE-4M flange				

Peak pressure is the highest allowable pressure, may occur for max. 1% of every minute;

* Intermittent speed (flow): for pressure up to 150[2200] bar[PSI];

** Intermittent load: the permissible values may occur for max. 10% of motor lifetime;

*** Theoretical torque;

**** The calculated max values are based on the optimal direction of the forces Fr, Fa and optimal position of the shaft.

***** The constant values are used for calculation of torque and speed with motor efficiencies $\eta_v=0.95$ and $\eta_{mh}=0.9$.

1. The recommended output power for continuous operations should not be exceeded.
2. Recommended filtration as per ISO 4406 cleanliness code 18/16/13 or better. This filtration corresponds to SAE AS 4059 8A/7B/7C. Nominal filtration - 10 micron or better.
3. Recommended a premium quality, anti-wear type mineral based hydraulic oil, HLP(DIN51524) or HM(ISO6743/4).
4. Recommended oil viscosity - 12...68 cSt or see page 84.
5. Recommended maximum system operating temperature - 82°[180°] C[F].
6. To ensure optimum life of the motor, fill it up with fluid prior to load it and run with moderate load and speed for about 10-15 minutes.

Hint: Motor Torque = Torque Constant * Pressure Drop

Rotation Speed = Speed Constant * Oil Flow

The constant values are approximate. Motor torque and rotation speed for a particular project are depending on the real operating conditions. For more detailed calculations please see efficiencies on page 74 and formulas on page 85.



OVERALL DIMENSIONS AND PORTS

Side Ports - Default Mounting Flange - Type SAE 4C and 4L

Standard Rotation
Viewed from shaft end
Port A Pressurized - CW
Port B Pressurized - CCW
see page 81

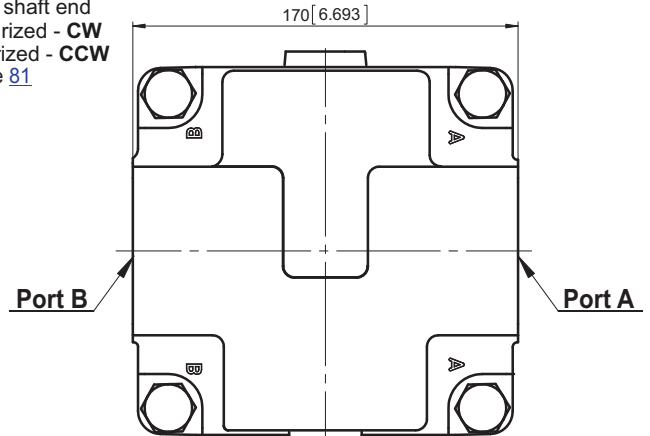
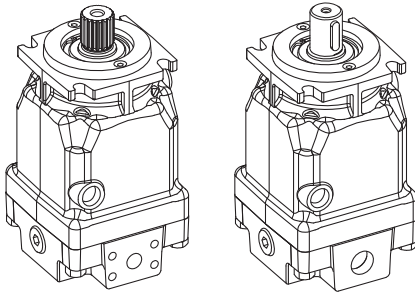

Side ports, port size default, 5 and 9

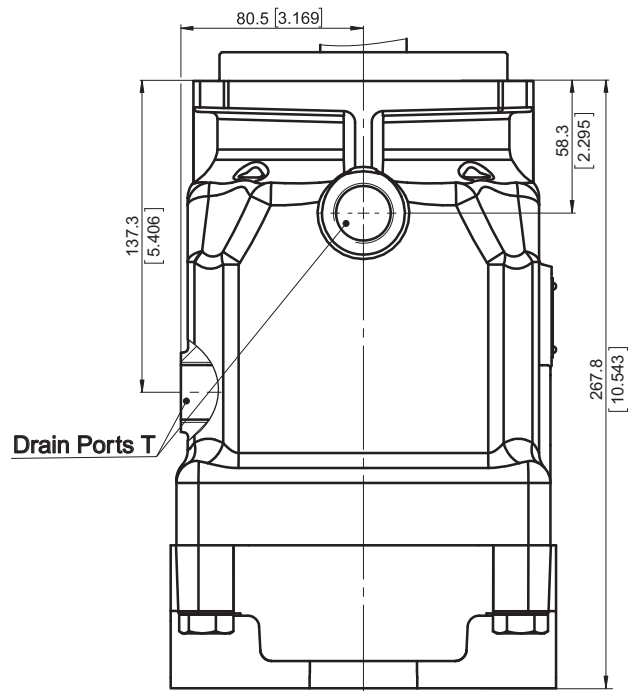
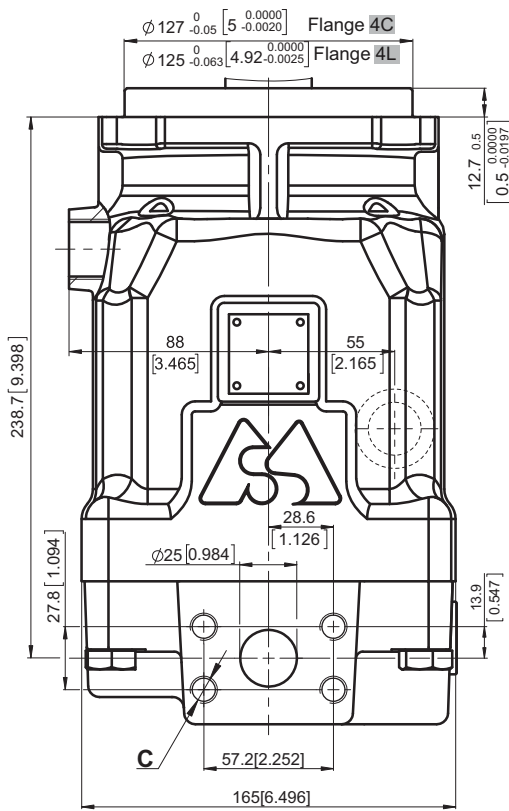

	Port Size		
	default	5	9
P_(A,B)	2xISO 6162-2 DN25	2xSAE J518 1" PSI6000	2xISO 6162-2 DN25
T	M27x2	1 1/16-12 UN	G 3/4
C	8xM12	8x7/16-14 UNC	8xM12

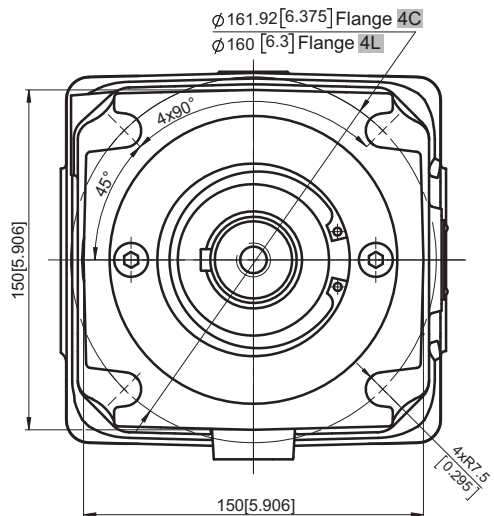

Side ports, port size 2 and 4

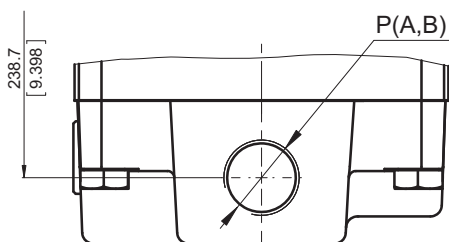

	Port Size	
	2	4
P_(A,B)	2xG 1	2x1 5/16-12UN
T	G 3/4	1 1/16-12UN

Shaft Mounting
see page 38

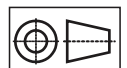

mm [in]



OVERALL DIMENSIONS AND PORTS

Rear Ports - Type E Mounting Flange - Type SAE 4C and 4L

Standard Rotation
Viewed from shaft end
Port A Pressurized - CW
Port B Pressurized - CCW
see page 81

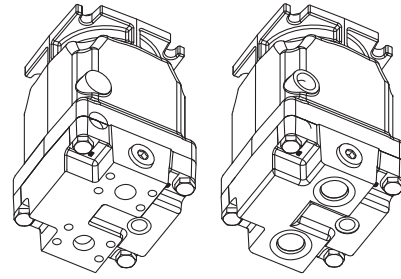

Rear ports, port size default, 5 and 9

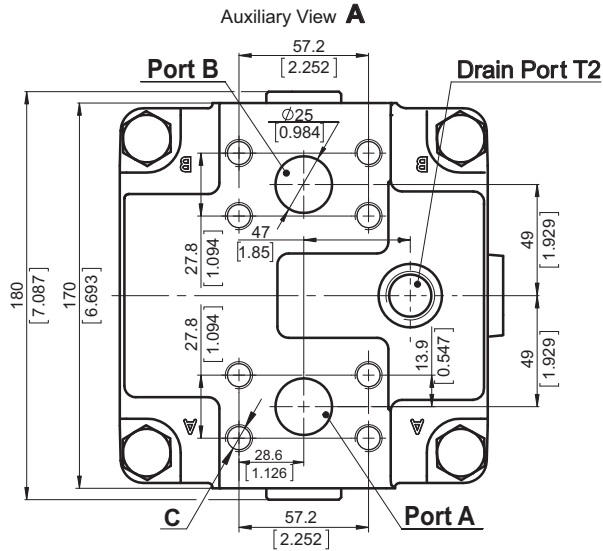

	Port Size		
	default	5	9
P_(A,B)	2xISO 6162-2 DN25	2xSAE J518 1" PSI6000	2xISO 6162-2 DN25
T1	M27x2	1 1/16-12 UN	G 3/4
T2	M22x1.5	7/8-14 UNF	G 1/2
C	8xM12	8x7/16-14 UNC	8xM12

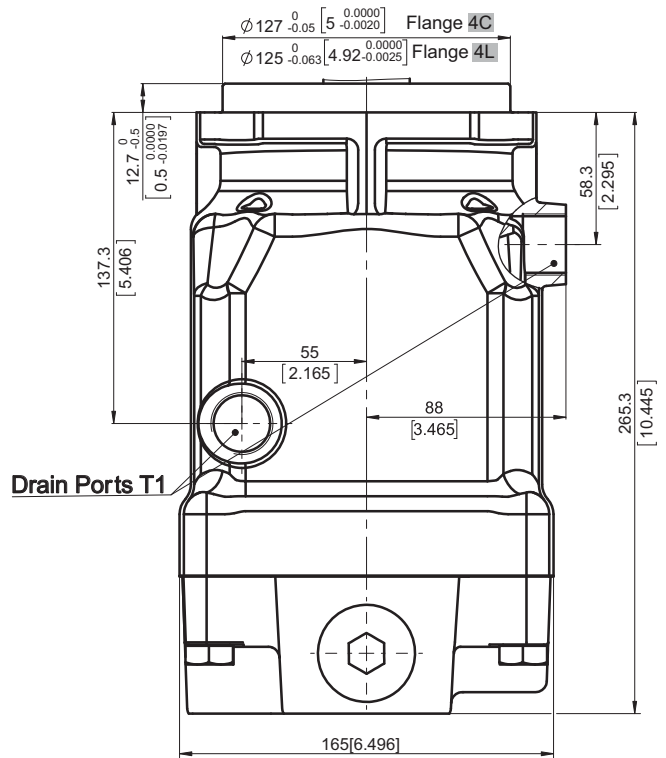

Rear ports, port size 2 and 4

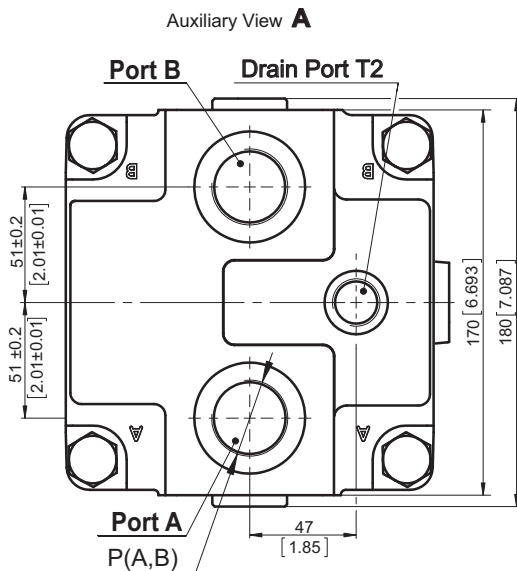

	Port Size	
	2	4
P_(A,B)	2xG 1	2x1 3/16-12UN
T1	G 3/4	1 1/16-12UN
T2	G 1/2	7/8 - 14 UNF

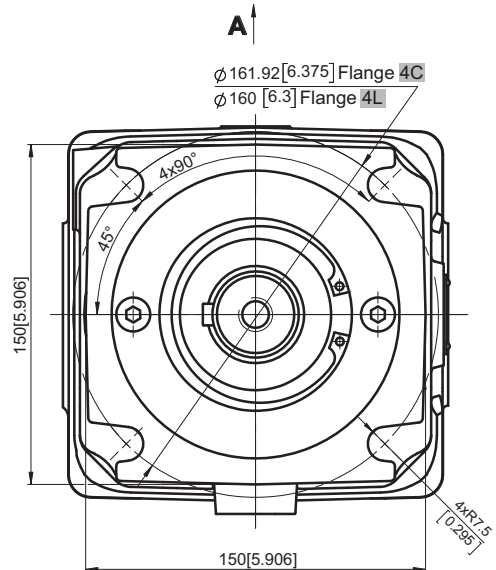

Shaft Mounting
see page 38

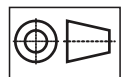

mm [in]



OVERALL DIMENSIONS AND PORTS

Twin Side Ports - Type T Mounting Flange - Type SAE 4C and 4L

Standard Rotation
Viewed from shaft end
Port A Pressurized - CW
Port B Pressurized - CCW
see page 81

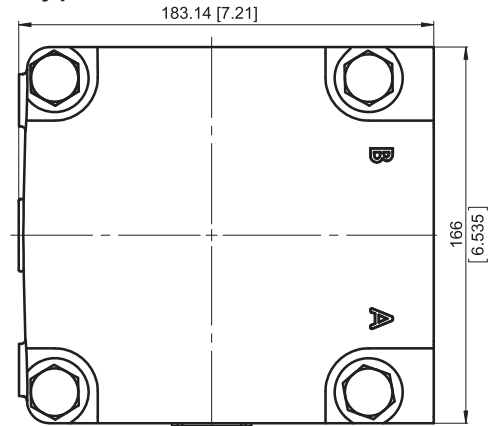
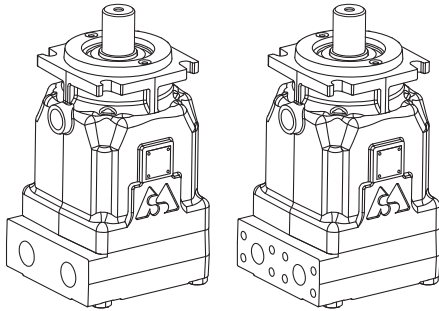

Twin side ports, port size default, 5 and 9

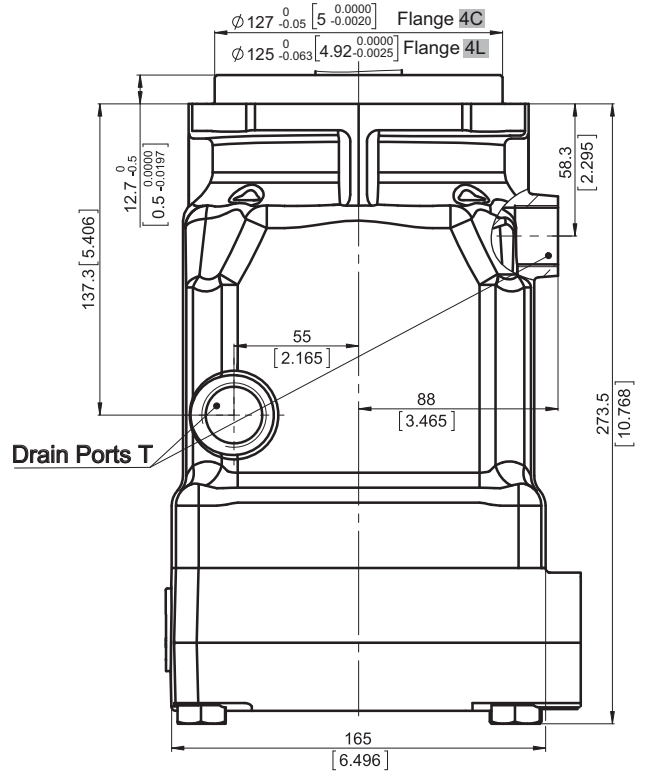
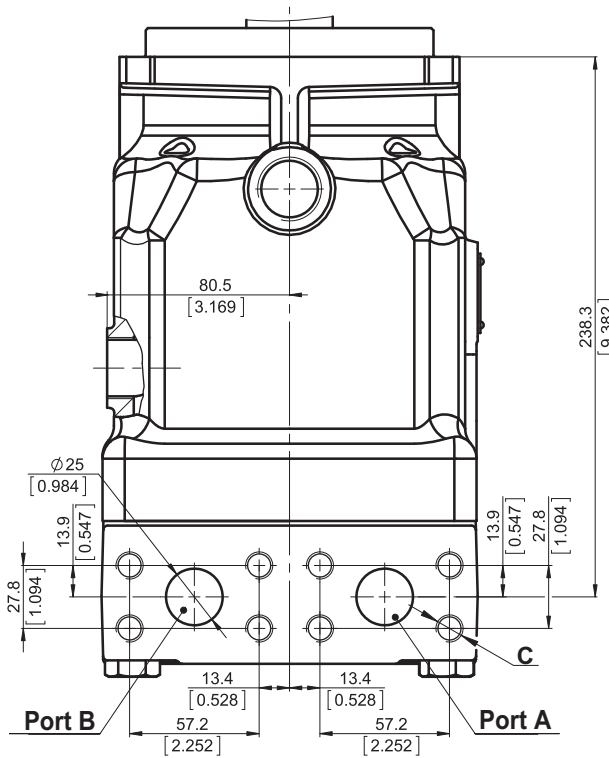

	Port Size		
	default	5	9
P_(A,B)	2xISO 6162-2 DN25	2xSAE J518 1" PSI6000	2xISO 6162-2 DN25
T	M27x2	1 1/16-12 UN	G 3/4
C	8xM12	8x7/16-14 UNC	8xM12

Twin side ports, port size 2 and 4

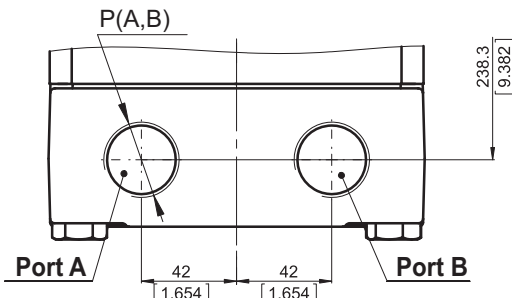

	Port Size	
	2	4
P_(A,B)	2xG 1	2x1 5/16-12UN
T	G 3/4	1 1/16-12UN

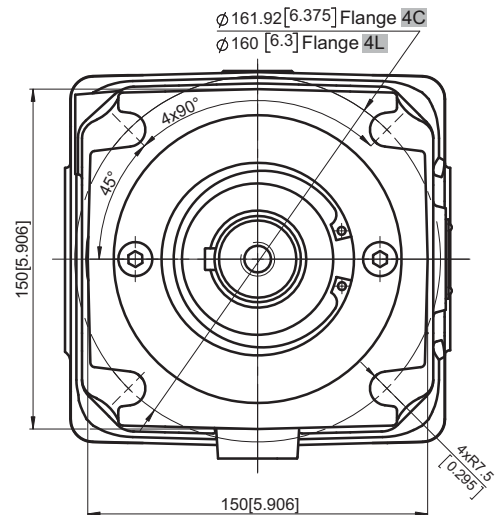

Shaft Mounting
see page 38

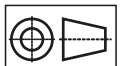

mm [in]



SHAFTS MOUNTING

Flange - Type SAE 4C and 4L

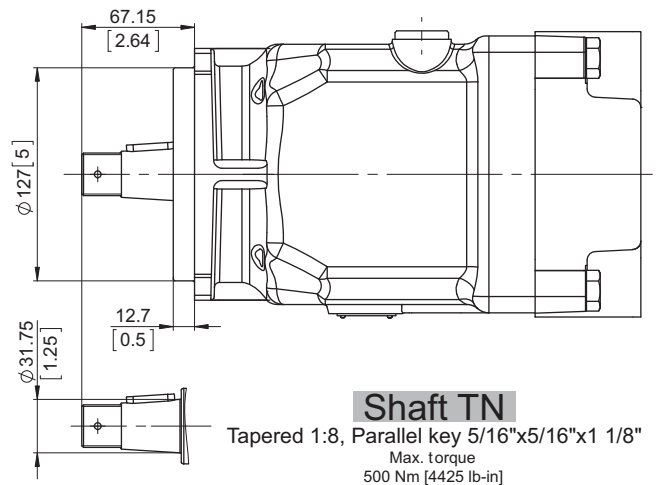
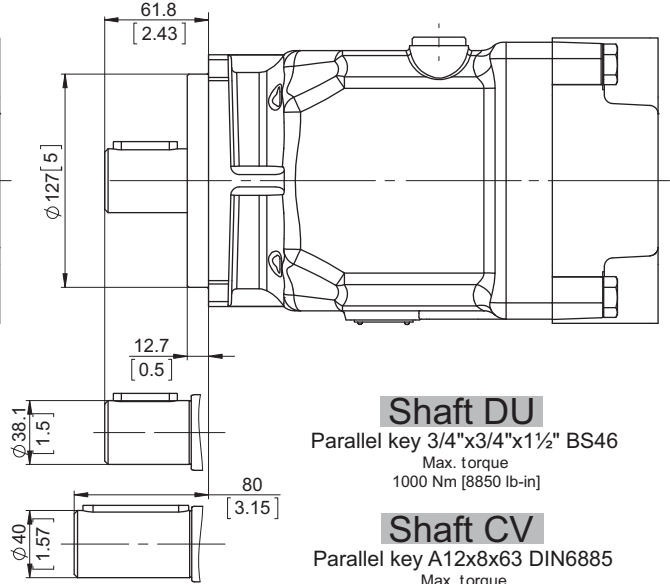
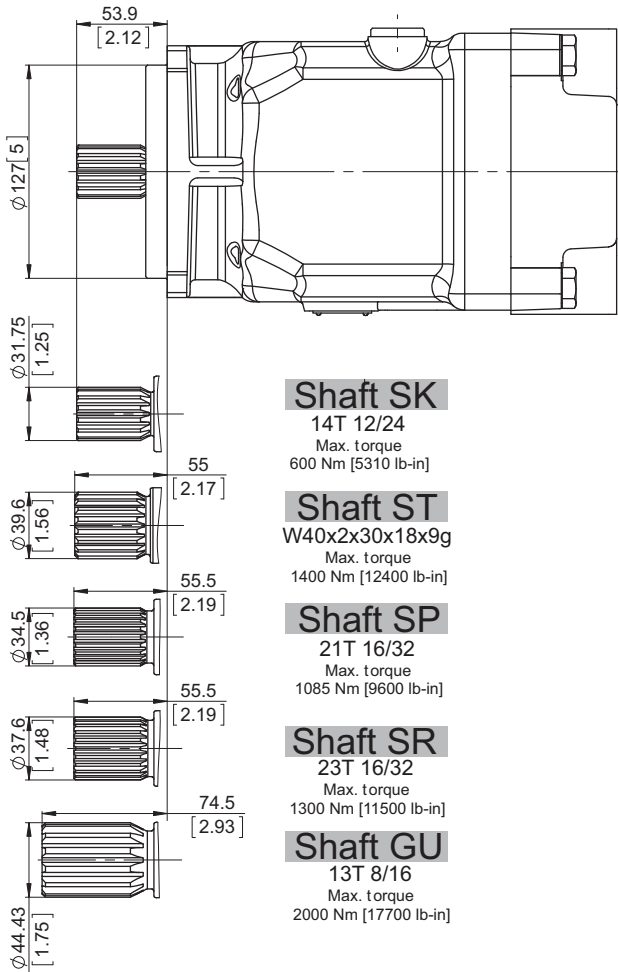

Shaft Dimensions
See Page [69+73](#)

PERMISSIBLE SHAFT LOAD

Permissible shaft load		
max Axial	N[lb]	Fa=2500 [562]
max Radial	N[lb]	Fr=4500 [1010]

The calculated max values are based on the optimal direction of the forces Fr, Fa and optimal position of the shaft (see page [81](#)).

For more information, please, feel free to contact us.

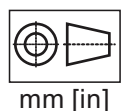



OVERALL DIMENSIONS AND PORTS

Side Ports - Default Mounting Flange - Type 4M

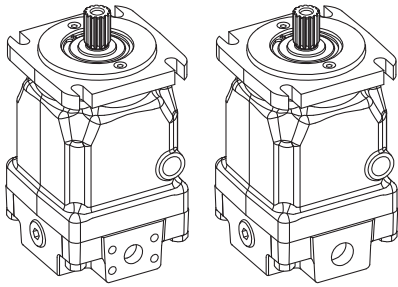

Standard Rotation
Viewed from shaft end
Port A Pressurized - CW
Port B Pressurized - CCW
see page 81

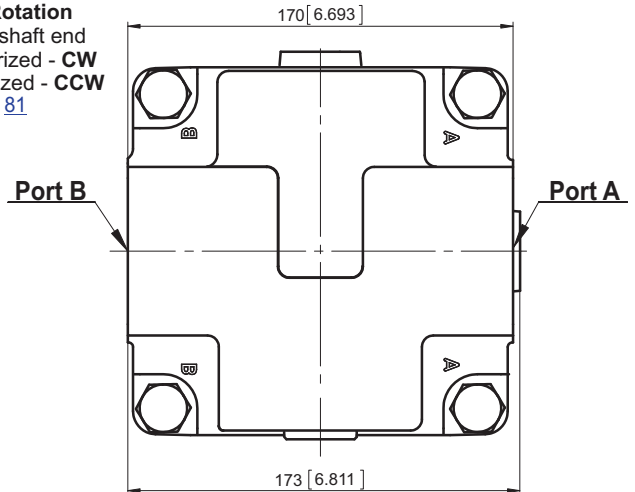

Side ports, port size default, 5 and 9

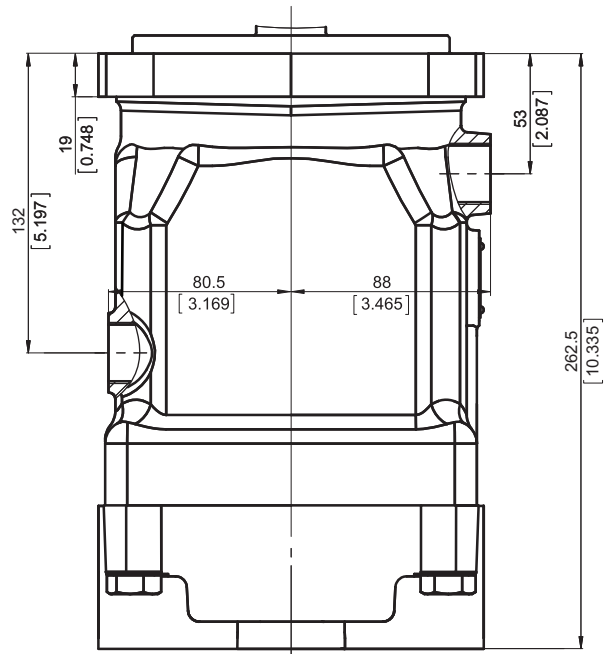
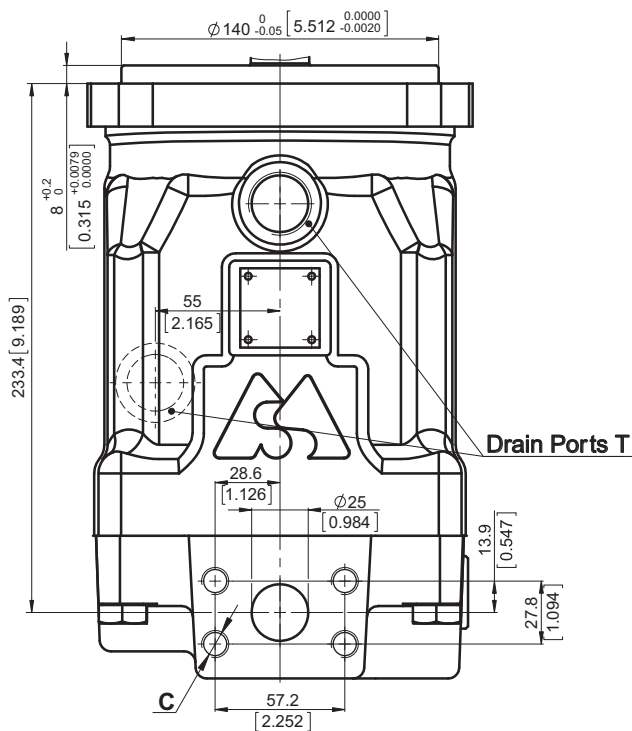

	Port Size		
	default	5	9
P _(A,B)	2xISO 6162-2 DN25	2xSAE J518 1" PSI6000	2xISO 6162-2 DN25
T	M27x2	1 1/16-12 UN	G 3/4
C	8xM12	8x7/16-14 UNC	8xM12

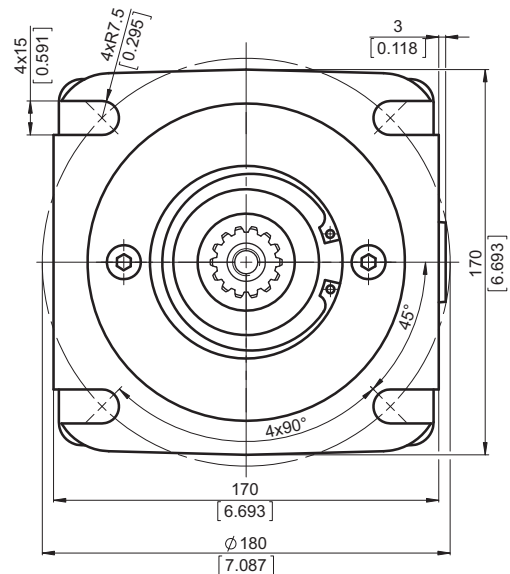

Side ports, port size 2 and 4

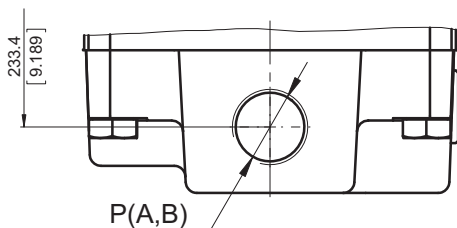

	Port Size	
	2	4
P _(A,B)	2xG 1	2x1 5/16-12UN
T	G 3/4	1 1/16-12UN

Shaft Mounting
see page 42

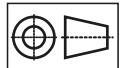

mm [in]



OVERALL DIMENSIONS AND PORTS

Rear Ports - Type E Mounting Flange - Type 4M

Standard Rotation
Viewed from shaft end
Port A Pressurized - CW
Port B Pressurized - CCW
see page 81

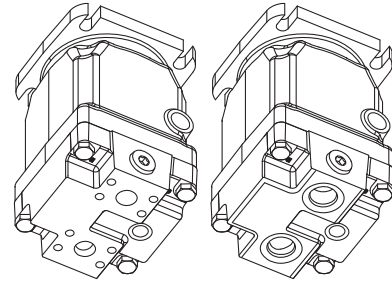

Rear ports, port size default, 5 and 9

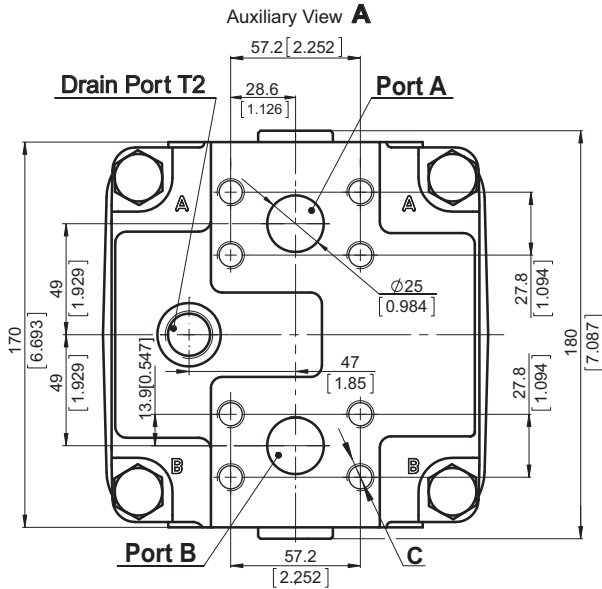

	Port Size		
	default	5	9
P _(A,B)	2xISO 6162-2 DN25	2xSAE J518 1" PSI6000	2xISO 6162-2 DN25
T1	M27x2	1 1/16 -12 UN	G 3/4
T2	M22x1.5	7/8-14 UNF	G 1/2
C	8xM12	8x7/16-14 UNC	8xM12

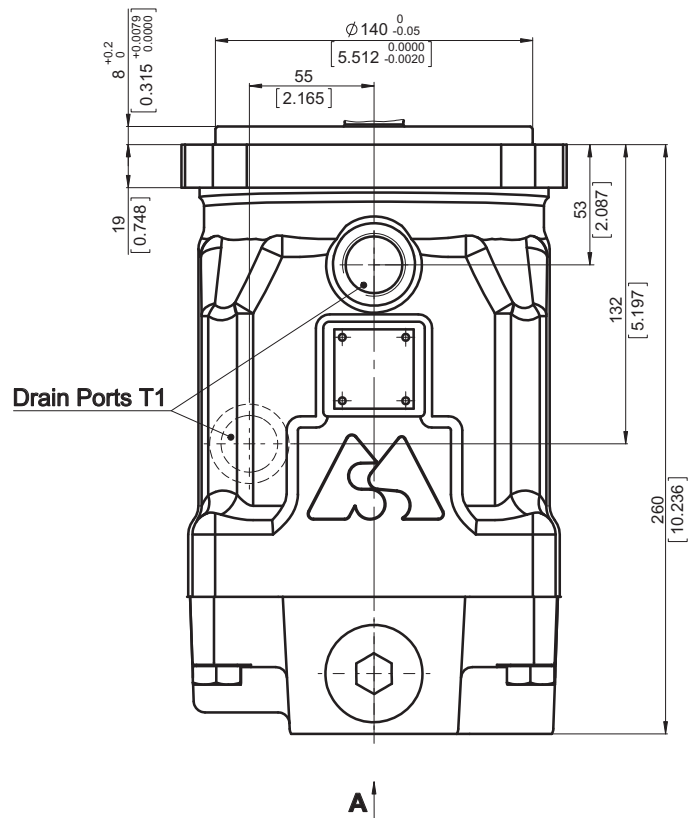

Rear ports, port size 2 and 4

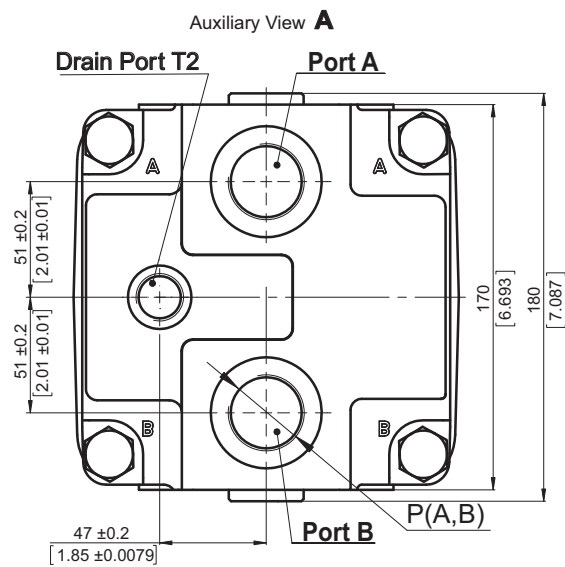

	Port Size	
	2	4
P _(A,B)	2xG 1	2x1 5/16-12UN
T1	G 3/4	1 1/16-12UN
T2	G 1/2	7/8 - 14 UNF

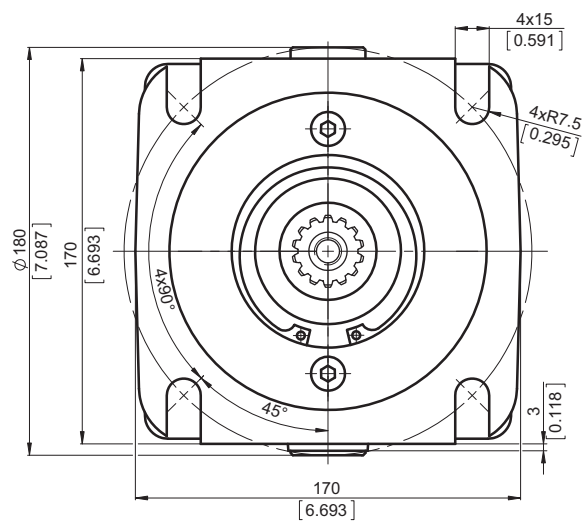

Shaft Mounting
see page 42

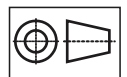

mm [in]



OVERALL DIMENSIONS AND PORTS

Twin Side Ports - Type T Mounting Flange - Type 4M

Standard Rotation
Viewed from shaft end
Port A Pressurized - CW
Port B Pressurized - CCW
see page 81

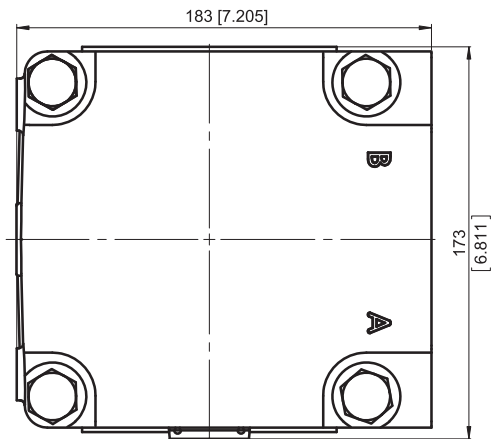
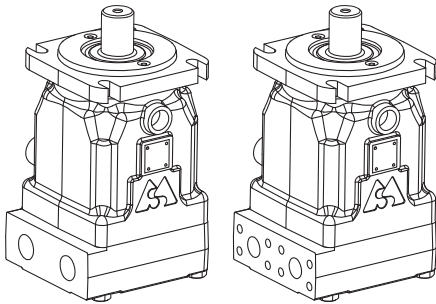

Twin side ports, port size default, 5 and 9

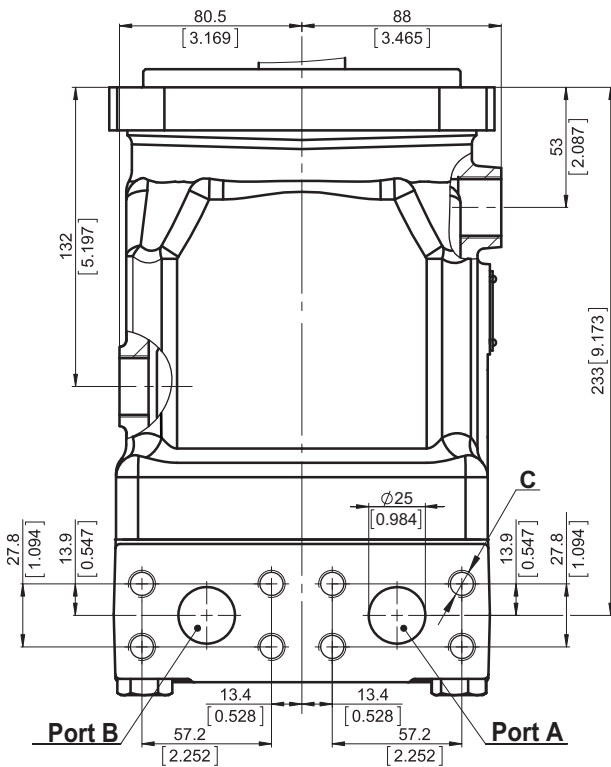

	Port Size		
	default	5	9
P _(A,B)	2xISO 6162-2 DN25	2xSAE J518 1" PSI6000	2xISO 6162-2 DN25
T	M27x2	1 1/16 -12 UN	G 3/4
C	8xM12	8x7/16-14 UNC	8xM12

Twin side ports, port size 2 and 4

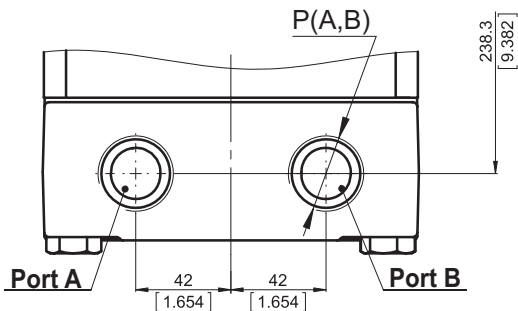

	Port Size	
	2	4
P _(A,B)	2xG 1	2x1 1/16-12UN
T	G 3/4	1 1/16-12UN

Drain Ports T

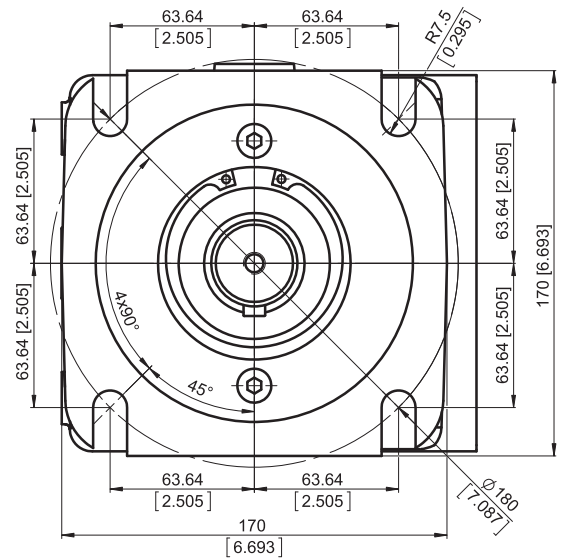
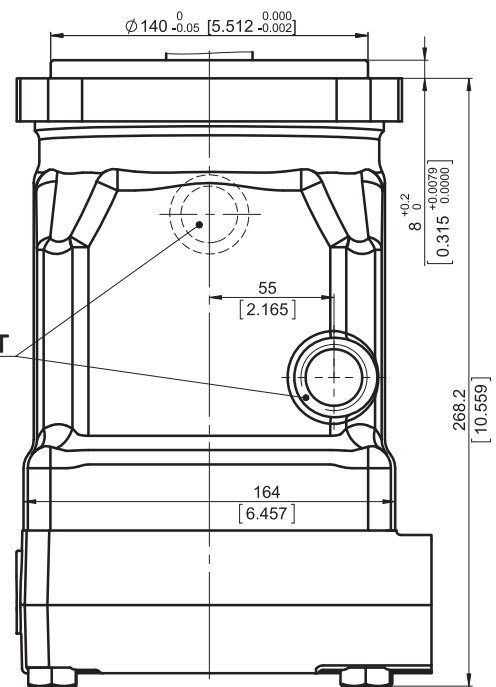

Shaft Mounting
see page 42

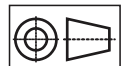

mm [in]

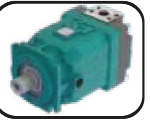

SHAFTS MOUNTING

Flange - Type 4M

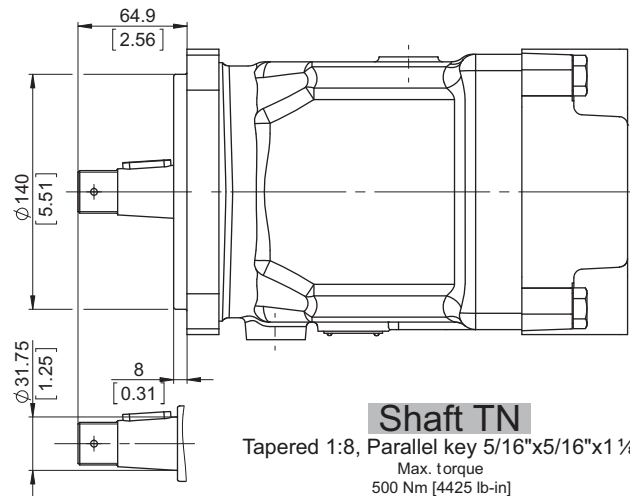
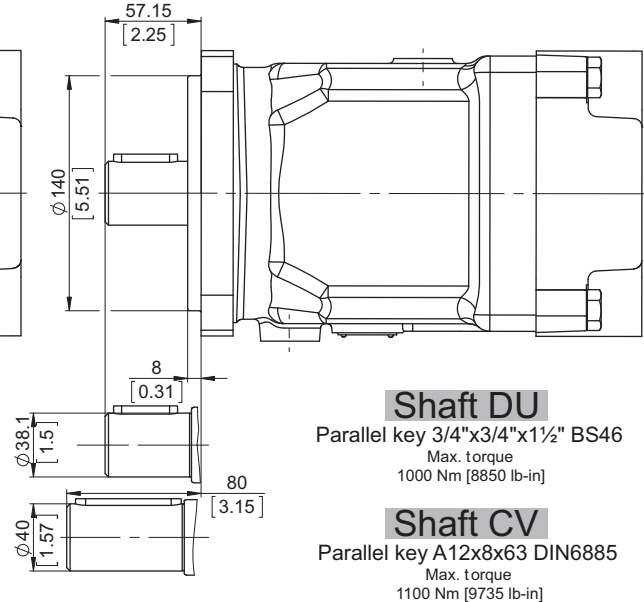
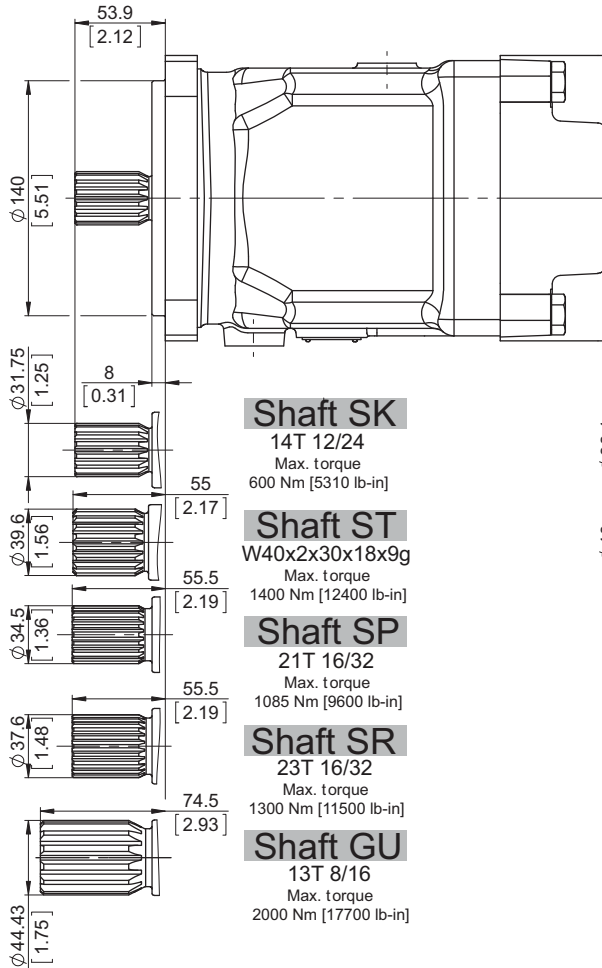

Shaft Dimensions
See Page 69+73

PERMISSIBLE SHAFT LOAD

Permissible shaft load		
max Axial	N[lb]	Fa=2500 [562]
max Radial	N[lb]	Fr=4500 [1010]

The calculated max values are based on the optimal direction of the forces Fr, Fa and optimal position of the shaft (see page 81).

For more information, please, feel free to contact us.

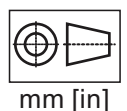

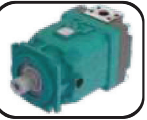

ORDERING CODE

	1	2	3	4	5	6	7	8	9	10	11	12	13	13	13
M A P													[]

Pos.1 - Mounting Flange

- 4M** - ISO3019-2 4-Bolt flange of spigot diam.140 [5.51"] - BC 180 [7.09"]
- 4C** - SAE C - 4-Bolt flange spigot diam. 127 [5"] - BC 161.92 [6.375"]
- 4L** - 4-Bolt flange spigot diam. 125 [4.92"] - BC 160 [6.3"]

Pos.2 - Port Type

- omit - Side ports on opposite sides
- T*** - Twin (Two) side ports on one side
- E** - Rear ports

Pos.3 - Displacement Code

- 63** - 63.58 cm³/rev [3.88 in³/rev]
- 71** - 71.5 cm³/rev [4.36 in³/rev]
- 75** - 76.84 cm³/rev [4.69 in³/rev]
- 92** - 93.18 cm³/rev [5.69 in³/rev]
- 100** - 98.75 cm³/rev [6.03 in³/rev]

Pos.4 - Shaft Extensions**

- SK** - ø31.75 [1.25"] Spline SAE 14T 12/24 DP, M10
- SP** - ø34.5 [1.358"] Spline SAE 21T 16/32 DP, M12
- SR** - ø37.6 [1.48"] Spline SAE 23T 16/32 DP, M12
- ST** - ø40 [1.575"] Spline W40x2x30x18x9g DIN 5480, M12 thread
- GU** - ø43.71 [1.721"] Spline SAE 13T 8/16 DP, 3/8-16UNC
- DU** - ø38.1[1.5"] Straight, key 9.528[0.375"] L38.1[1.5"], 3/8-16 UNC thread
- CV** - ø40 [1.575"] Straight, M12 thread Parallel key A12x8x63 DIN6885
- TN** - ø31.75 [1.25"] Tapered 125:1000, key 7.94[5/16"] x7.94[5/16"] L28[1 1/8"], 1-12 UNF

Pos.5 - Ports

- omit - 2xISO 6162-2 DN25, drain ports M27x2, for rear drain port M22x1.5
- 2** - 2xG1, drain G3/4, for rear drain ports G1/2
- 4** - 2x1 5/16-12 UN Ports, drain ports 1 1/16 UNF for rear drain port 7/8-14 UNF
- 5** - 2xSAE 1", PSI6000, drain ports 1 1/16 UNF for rear drain port 7/8-14 UNF
- 9** - 2xISO 6162-2 DN25, drain ports G3/4, for rear drain port G1/2

Pos.6 - Seal, Corrosion Resistant Seal Surface

- omit - NBR seal type material
- V** - FKM seal type material

Pos.7 - Integrated Valves

- See page [77+78](#) for information about valves
- omit - None
- HR** - Single anti-cavitation valve
- AR** - Dual anti-cavitation valve
- PU** - Purge valve - default - 7±2 l/min
- FLU** - Flush valve - default - 7±2 l/min at 20 bar
- SAR** - Single anti-cavitation and relief valve
- DAR** - Dual anti-cavitation and relief valve
- DARP** - Dual anti-cavitation, relief and purge valve, default flow - 7±2 l/min
- DARF** - Dual anti-cavitation, relief and flush valve, default flow - 7±2 l/min at 20 bar

Pos.8 - Valve's Port for Single Valves

- omit - None
- A** - Port A
- B** - Port B

Pos.9 - Pressure Setting of Integrated Valves

- omit - None
- x** -

250	300	350
-----	-----	-----

 for more information see page [77+78](#)

Pos.10 - Flow Setting of Integrated Valves

- omit - None
- Lx** - For value - see page [77+78](#)

Pos.11 - Special Features*

- omit - None
- R2S** - Speed Sensor Two Directional (see page [79](#))
- R** - Reverse Rotation (see page [81](#))

Pos.12 - Paint and Coating

- omit - No paint or coating
- P** - Painted
- PC** - Corrosion protected paint

If a painting option is required, the standard color is black-Alkyd-Styrenated Enamel, Black RAL 9005. Other color by customer's request.

Pos.13 - Design Series

- omit - Factory specified

**The permissible output torque for shafts must not be exceeded!

EXAMPLE

MAP4CE100ST2

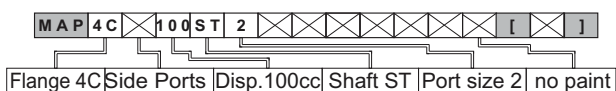

MAP4ME92GS4P

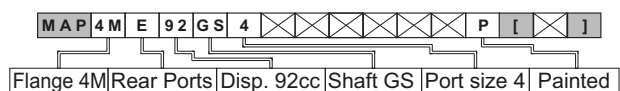

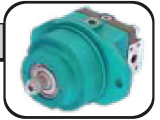

Hydraulic Motors Type MAPW62

Heavy Duty Axial Piston Motors Fixed Displacement

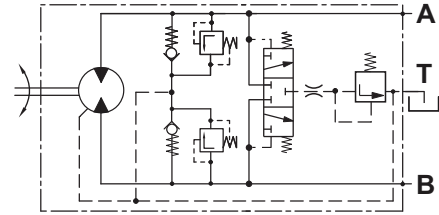
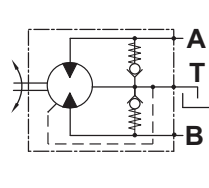
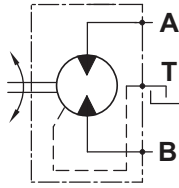

open drain line is always required

APPLICATION

- » Agricultural machines
- » Road building machines
- » Mining machinery
- » Food industry machines
- » Swing drives
- » Hydraulic transmissions
- » Vibration machines
- » Fan drives
- » Special vehicles

OPTIONS

- » Port options
- » Shaft options
- » High pressure ports
- » Integrated valves

ADVANTAGES

- » High starting torque
- » Smooth operation
- » Long service life
- » High power density

GENERAL

Displacement,	cm ³ /rev [in ³ /rev]	36.16÷62.4 [2.21÷3.81]
Max. Speed,	RPM	4000
Max. Torque,	Nm [lb-in]	320 [2832]
Max. Output,	kW [HP]	80 [107]
Max. Pressure Drop,	bar [PSI]	350 [5080]
Max. Oil Flow,	l/min [GPM]	200 [52.8]
Min. Speed,	RPM	500
Fluid	Mineral based- HLP(DIN 51524) or HM(ISO 6743/4)	
Temperature Range,	°C [°F]	-40÷82 [-40÷180]
Optimal Viscosity Range,	mm ² /s [SUS]	12÷68 [66÷311]
Filtration	ISO code 18/16/13 (Min. recommended fluid filtration of 10 micron)	

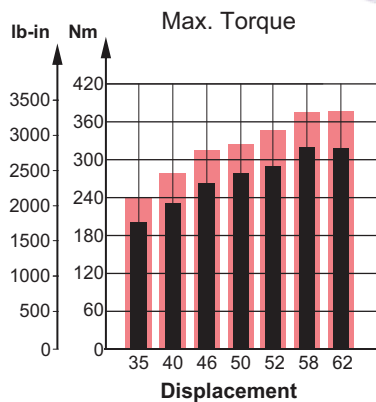

Intermittent values

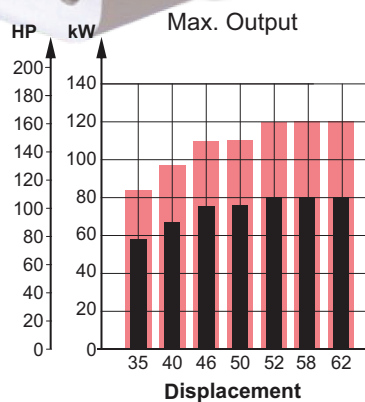

Continuous values

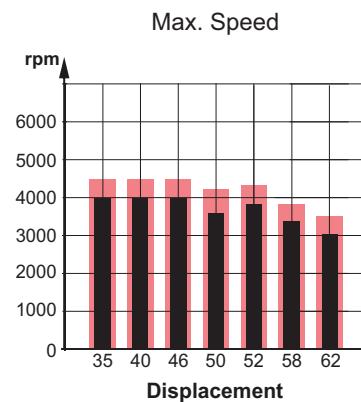

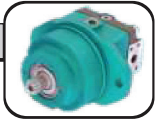

SECTION VIEW

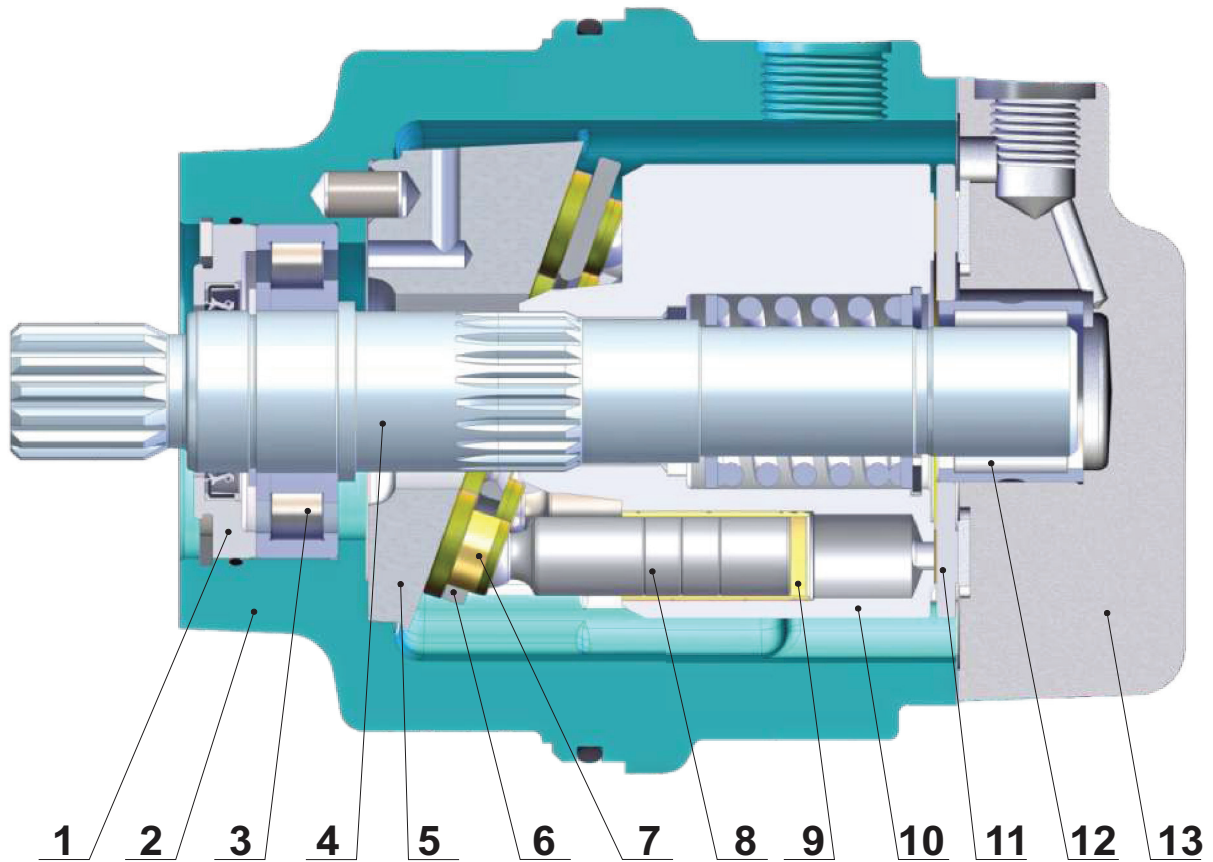

1. Front cover
2. Cast iron body
3. Robust radial - axial roller bearing
4. Hardened shaft
5. Solid swash plate
6. Retainer plate
7. Improved piston shoes
8. Improved pistons
9. Brass bushings
10. Hardened steel cylinder block
11. Bimetal distributor
12. Needle bearing
13. Solid end cover

The main advantages of the heavy duty design of the MAPW motors over the typical swash plate motors are the higher starting torque and the higher total efficiency. In regards to these two parameters, under normal working mode, the MAP is comparable to the bent axis motors. The advantages of the MAP over the bent axis motors are the higher reliability and the lower degree of pulsation and vibration during operation.

SPECIFICATION DATA

Type		MAPW 35	MAPW 40	MAPW 46	MAPW 50	MAPW 52	MAPW 58	MAPW 62	
Displacement, cm ³ /rev [in ³ /rev]		36.16	41.59	47.13	49.94	51.95	58.8	62.4	
		[2.21]	[2.54]	[2.88]	[3.05]	[3.17]	[3.59]	[3.81]	
Max. Speed, [RPM]	Cont.	4000	4000	4000	3600	3850	3398	3050	
	Int.*	4500	4500	4500	4200	4330	3823	3500	
Max. Torque,*** Nm [lb-in]	Cont.	202 [1789]	232 [2053]	263 [2328]	278 [2460]	290 [2566]	320 [2832]	318 [2814]	
	Int.**	242 [2142]	278 [2460]	315 [2788]	326 [2885]	347 [3071]	375 [3320]	377 [3337]	
Output, kW [HP]	Cont.	58 [78]	67 [90]	76 [102]	76 [102]	80 [107]	80 [107]	80 [107]	
	Int.**	84 [113]	97 [130]	110 [148]	110 [148]	120 [161]	120 [161]	120 [161]	
Max. Pressure, bar [PSI]	Cont.	350 [5080]	350 [5080]	350 [5080]	350 [5080]	350 [5080]	340 [4930]	320 [4640]	
	Int.**	420 [6100]	420 [6100]	420 [6100]	410 [5950]	420 [6100]	400 [5800]	380 [5510]	
	Peak	450 [6527]	450 [6527]	450 [6527]	450 [6527]	450 [6527]	440 [6381]	410 [5950]	
Max. Oil Flow, l/min [GPM]	Cont.	145 [38.3]	167 [44.1]	189 [50]	180 [47.5]	200 [52.8]	200 [52.8]	190 [50]	
	Int.*	163 [43.1]	187 [49.4]	212 [56]	210 [55.5]	225 [59.4]	225 [59.4]	215 [56.8]	
Torque Constant Nm/bar [lb-in/PSI]	*****	0.52	0.6	0.68	0.72	0.75	0.85	0.9	
		[0.32]	[0.364]	[0.41]	[0.437]	[0.454]	[0.515]	[0.546]	
Speed Constant RPM/(l/min) [RPM/GPM]	*****	26.3	22.84	20.2	19.02	18.28	16.13	15.23	
		[99.4]	[86.5]	[76.3]	[72]	[70.2]	[61.1]	[57.6]	
Permissible Shaft Load max Axial**** N[lb]		Fa=2000 [450]							
	max Radial**** N[lb]	Fr=3600 [810]							
Min. Speed, [RPM]		500							
Max. Pressure in Drain Line, bar [PSI]		5 [70] open drain line is always required							
Weight, kg [lb]		19.65 [43.3]							

Peak pressure is the highest allowable pressure, may occur for max. 1% of every minute;

* Intermittent speed (flow): for pressure up to 150[2200] bar[PSI];

** Intermittent load: the permissible values may occur for max. 10% of motor lifetime;

*** Theoretical torque;

**** The calculated max values are based on the optimal direction of the forces Fr, Fa and optimal position of the shaft.

***** The constant values are used for calculation of torque and speed with motor efficiencies $\eta_v=0.95$ and $\eta_{mh}=0.9$.

1. The recommended output power for continuous operations should not be exceeded.
2. Recommended filtration as per ISO 4406 cleanliness code 18/16/13 or better. This filtration corresponds to SAE AS 4059 8A/7B/7C. Nominal filtration - 10 micron or better.
3. Recommended a premium quality, anti-wear type mineral based hydraulic oil, HLP(DIN51524) or HM(ISO6743/4).
4. Recommended oil viscosity - 12...68 cSt or see page [84](#).
5. Recommended maximum system operating temperature - 82°[180°] C[F].
6. To ensure optimum life of the motor, fill it up with fluid prior to load it and run with moderate load and speed for about 10-15 minutes.

Hint: Motor Torque = Torque Constant * Pressure Drop

Rotation Speed = Speed Constant * Oil Flow

The constant values are approximate. Motor torque and rotation speed for a particular project are depending on the real operating conditions. For more detailed calculations please see efficiencies on page [74](#) and formulas on page [85](#).

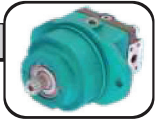

OVERALL DIMENSIONS AND PORTS

Side Ports - Default Mounting Flange-Type Cartage

Standard Rotation
Viewed from shaft end
Port A Pressurized - CW
Port B Pressurized - CCW
see page 81

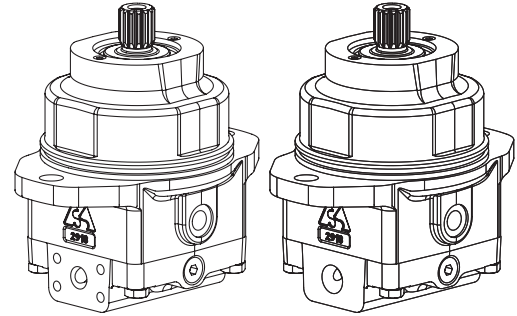
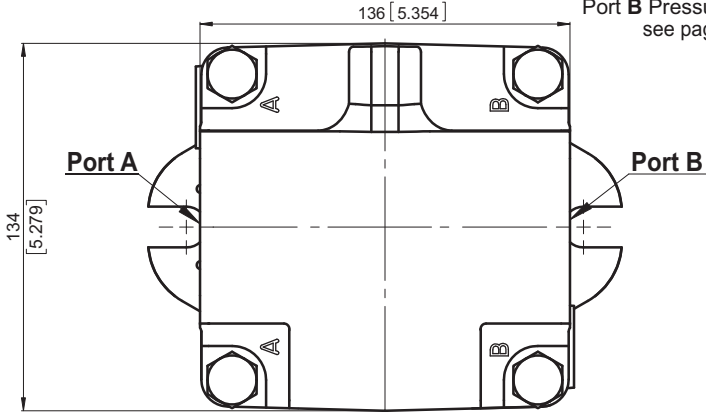

Side ports, port size default ,5 and 9

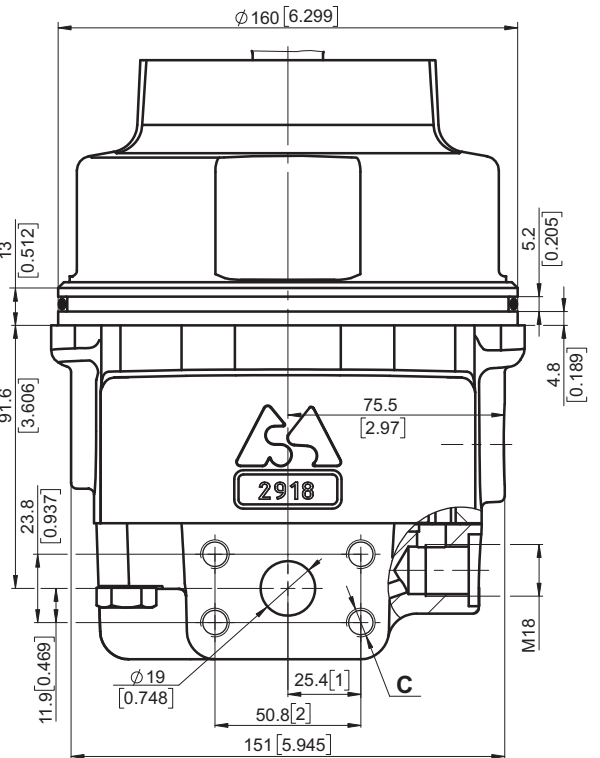
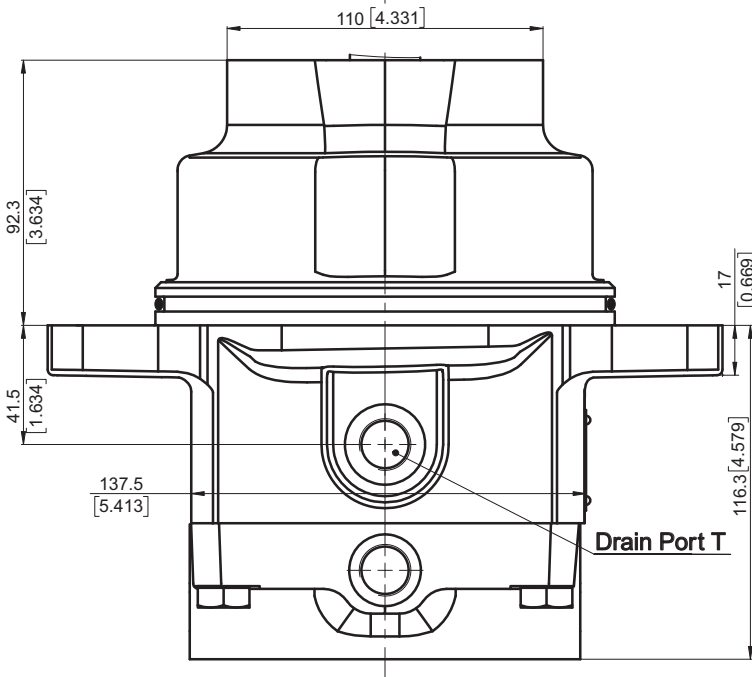

		Port Size		
		default	5	9
P _(A,B)	2xISO 6162-2 DN19	2xSAE J518 3/4 PSI6000	2xISO 6162-2 DN19	
T	M18x1.5	7/8-14 UNF	G1/2	
C	8xM10	8x3/8-16 UNC	8xM10	

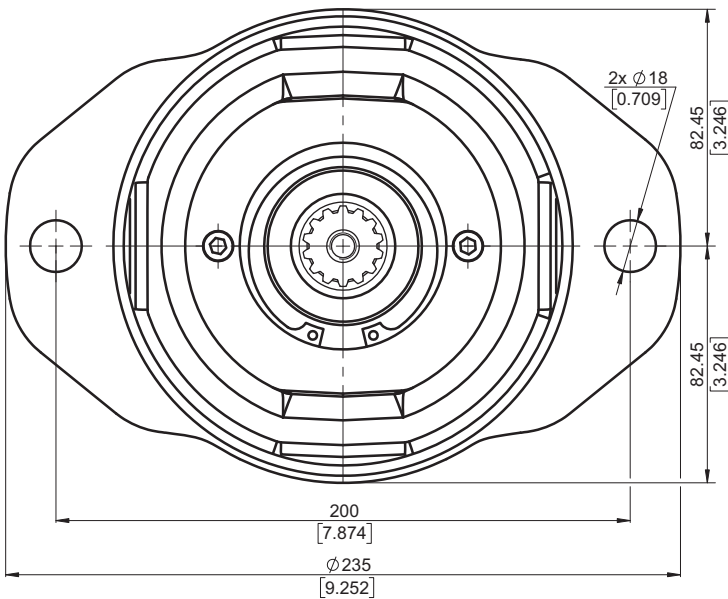

Side ports, port size 2 ,3 and 4

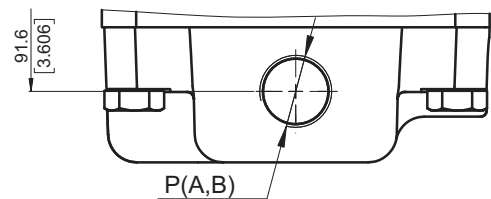

		Port Size		
		2	3	4
P _(A,B)	2xG 3/4	2xM27x2	2x1 1/16-12UN	
T	G 1/2	M18x1.5	7/8-14UNF	

Shaft Mounting
see page 50

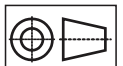

mm [in]

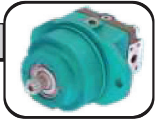

OVERALL DIMENSIONS AND PORTS

View without body, port size **default, 5 and 9** **Rear Ports - Type E**

View without body, port size **2, 3 and 4**

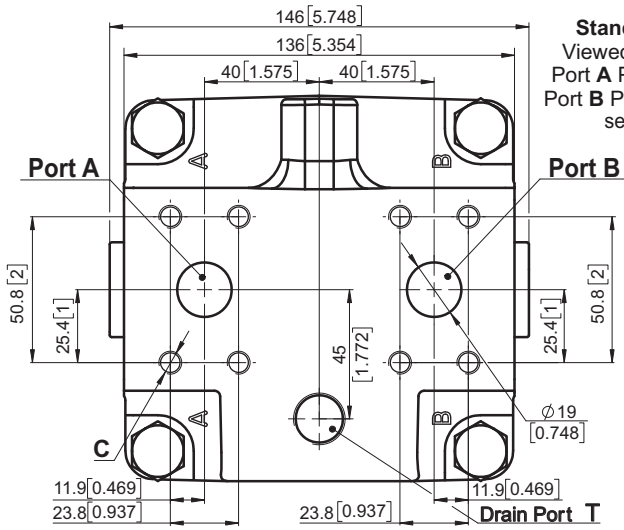

Standard Rotation
Viewed from shaft end
Port A Pressurized - CW
Port B Pressurized - CCW
see page 81

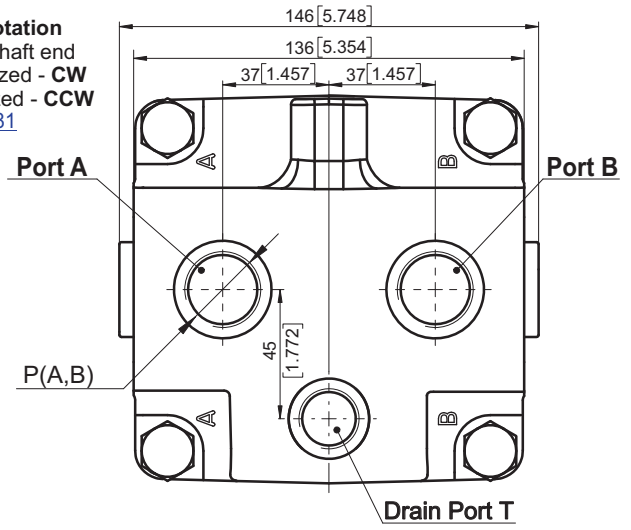

	Port Size		
	default	5	9
P _(A,B)	2xISO 6162-2 DN19	2xSAE J518 3/4 PSI6000	2xISO 6162-2 DN19
T	M18x1.5	7/8-14 UNF	G1/2
C	8xM10	8x3/8-16 UNC	8xM10

	Port Size		
	2	3	4
P _(A,B)	2xG 3/4	2xM27x2	2x1 1/16-12UN
T	G 1/2	M18x1.5	7/8-14UNF

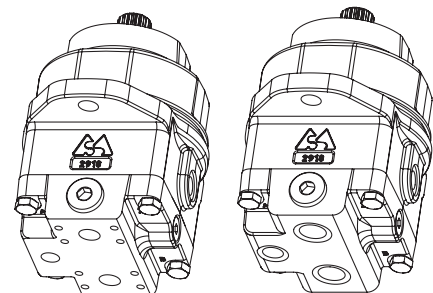
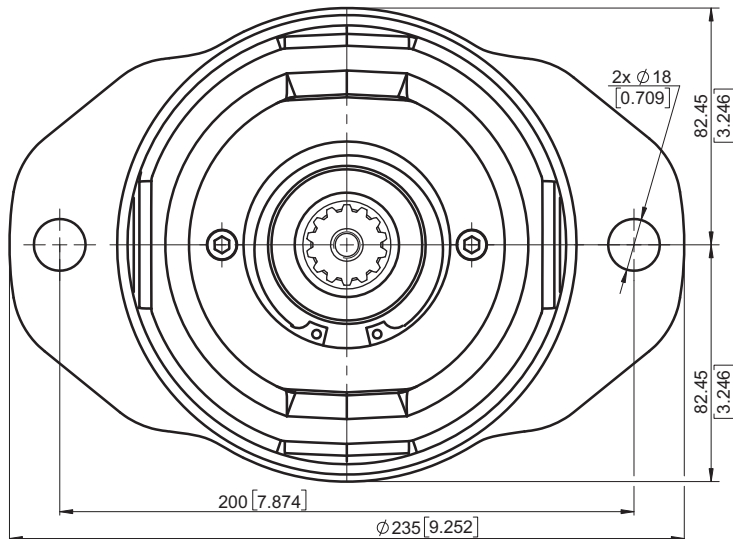
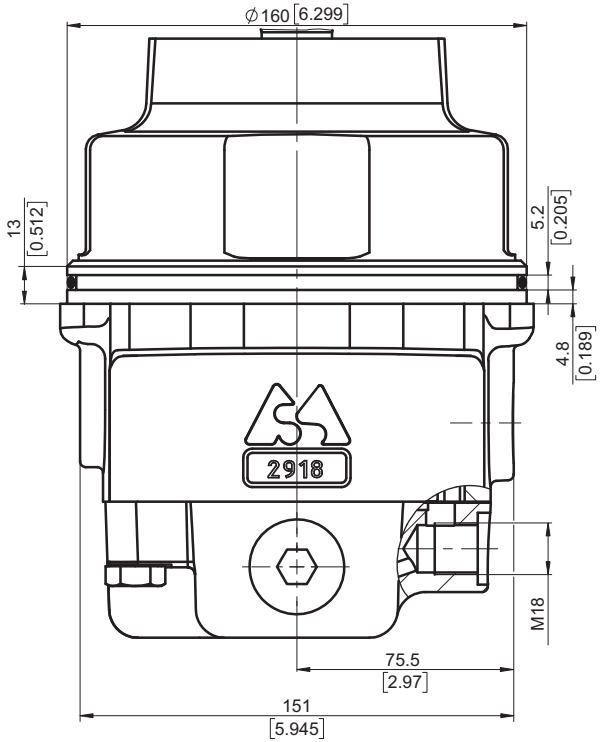
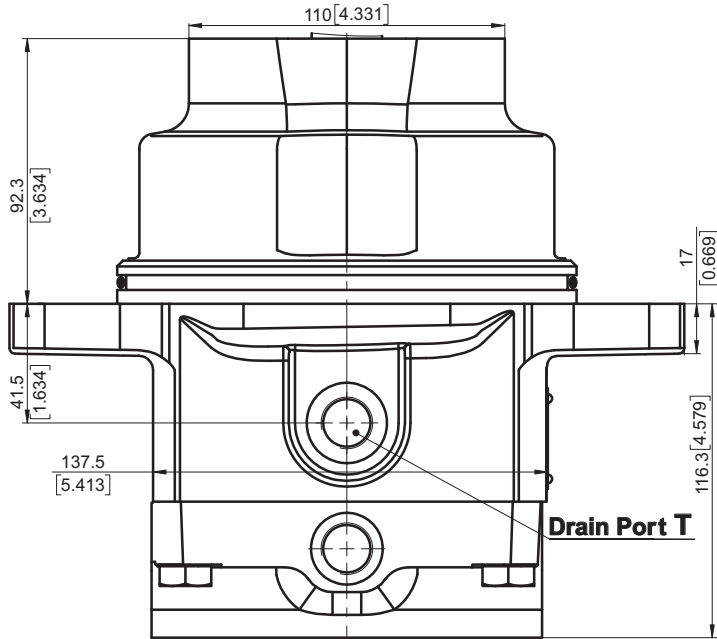

Shaft Mounting
see page 50

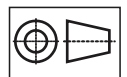

mm [in]

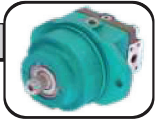

OVERALL DIMENSIONS AND PORTS

Twin Side Ports - Type T

Standard Rotation
Viewed from shaft end
Port A Pressurized - CW
Port B Pressurized - CCW
see page 81

Twin side ports, port size default ,5 and 9

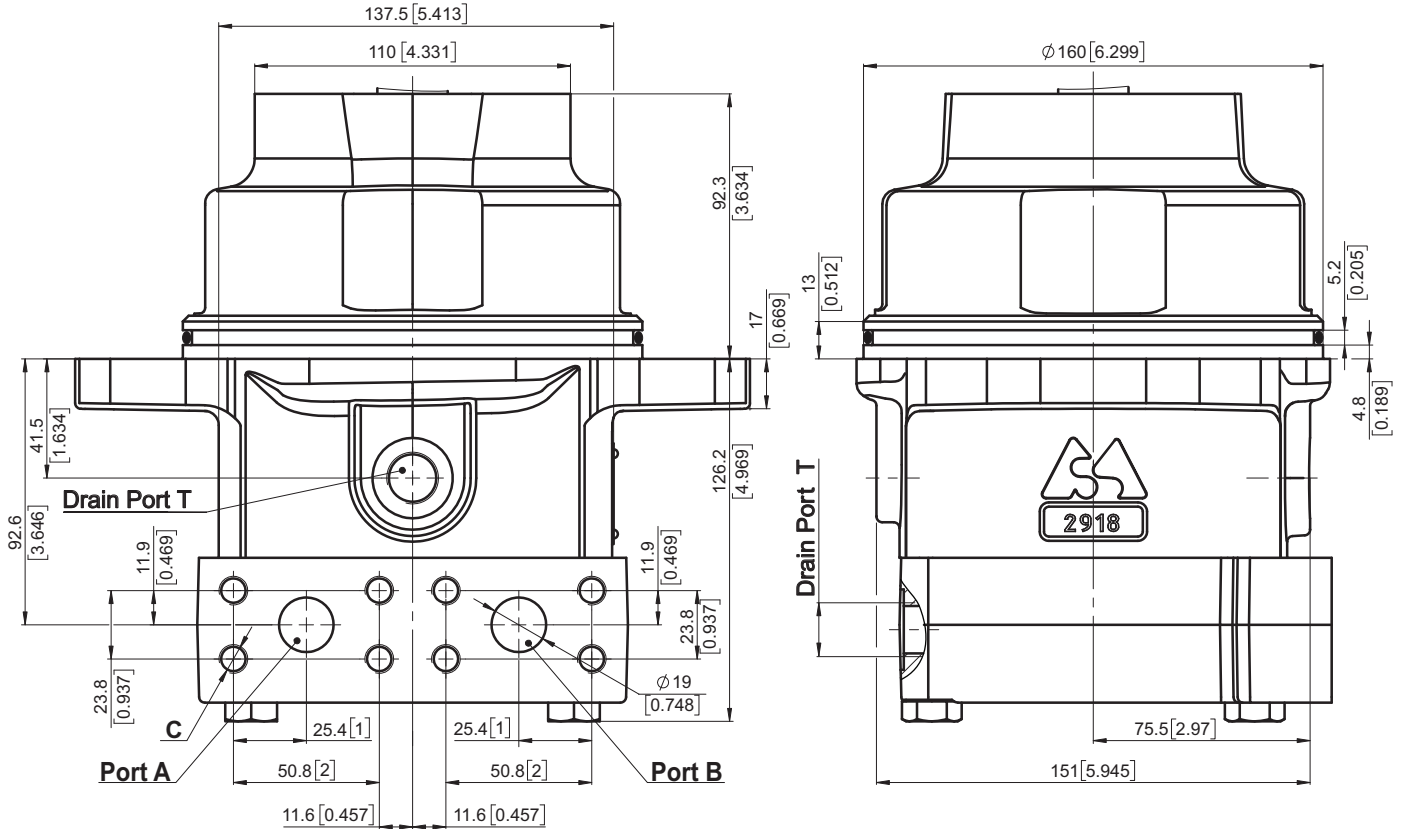

	Port Size		
	default	5	9
P _(A,B)	2xISO 6162-2 DN19	2xSAE J518 3/4 PSI6000	2xISO 6162-2 DN19
T	M18x1.5	7/8-14 UNF	G1/2
C	8xM10	8x3/8-16 UNC	8xM10

Twin side ports, port size 2 ,3 and 4

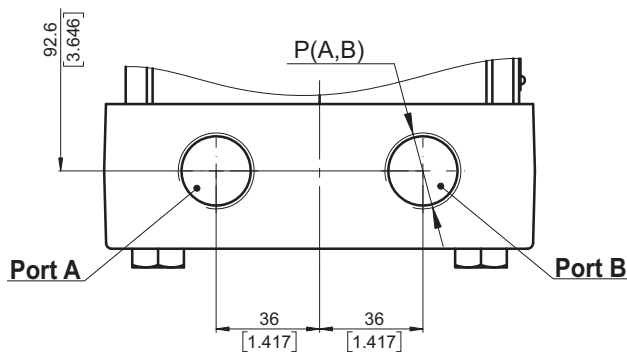

	Port Size		
	2	3	4
P _(A,B)	2xG 3/4	2xM27x2	2x1 1/16-12UN
T	G 1/2	M18x1.5	7/8-14UNF

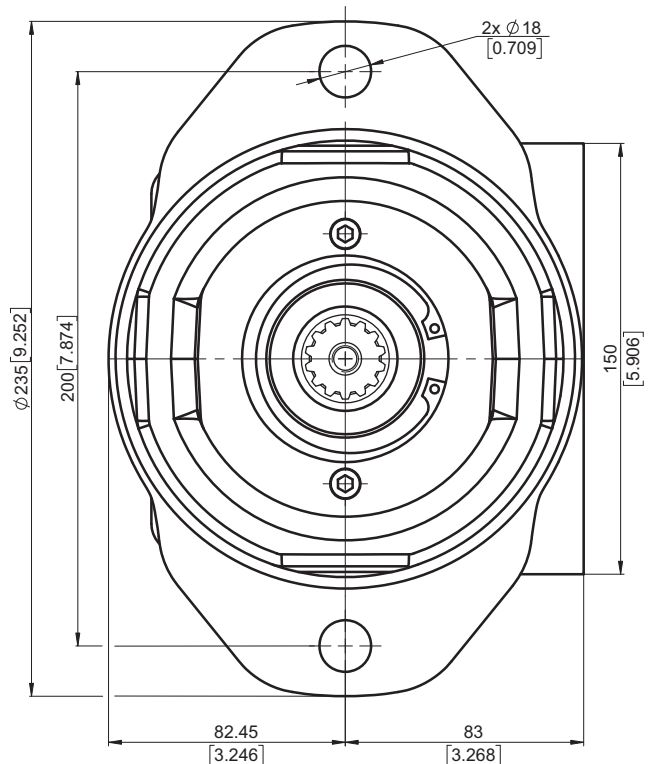

Shaft Mounting
see page 50

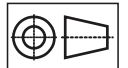

mm [in]

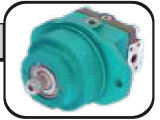

SHAFTS MOUNTING

Flange - Type Cartage

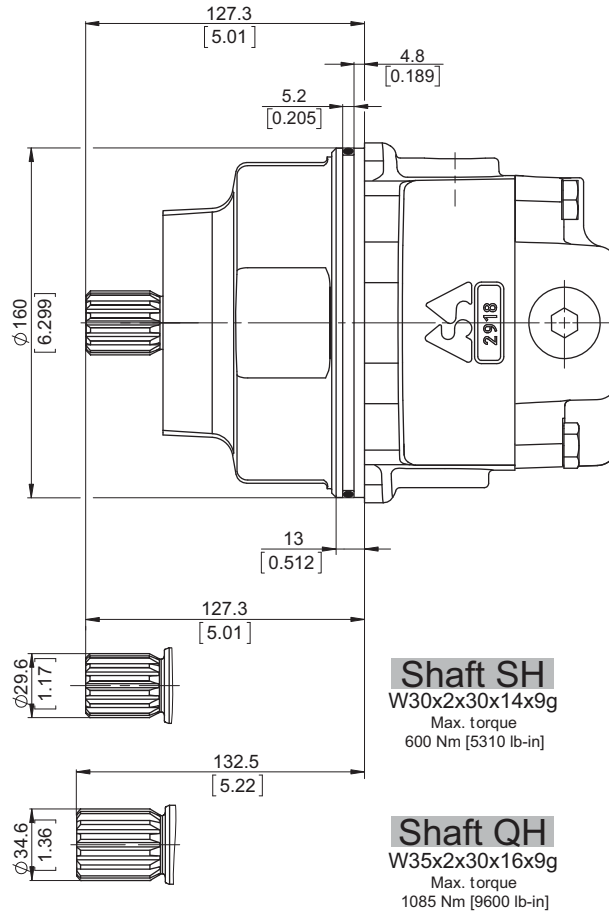

Shaft Dimensions
See Page [69+73](#)

PERMISSIBLE SHAFT LOAD

Permissible shaft load		
max Axial	N[lb]	Fa=2500 [562]
max Radial	N[lb]	Fr=4500 [1010]

The calculated max values are based on the optimal direction of the forces Fr, Fa and optimal position of the shaft (see page [81](#)).

For more information, please, feel free to contact us.

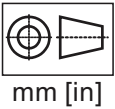

mm [in]

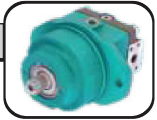

ORDERING CODE

	1	2	3	4	5	6	7	8	9	10	11	12	13	13	13
M A P W												[]	

- | | | | | |
|--|--|-----|-----|-----|
| <p>Pos.1 - Mounting Flange</p> <p>T - Wheel flange, cartage - 2 bolt flange spigot diam. 160 [6.3"] -BC 200 [7.87"]</p> <p>Pos.2 - Port Type</p> <p>omit - Side ports on opposite sides</p> <p>T - Twin (Two) side ports on one side</p> <p>E - Rear ports</p> <p>Pos.3 - Displacement Code</p> <p>35 - 36.16 cm³/rev [2.21 in³/rev]</p> <p>40 - 41.59 cm³/rev [2.54 in³/rev]</p> <p>46 - 47.13 cm³/rev [2.88 in³/rev]</p> <p>50 - 49.94 cm³/rev [3.05 in³/rev]</p> <p>52 - 51.95 cm³/rev [3.17 in³/rev]</p> <p>58 - 58.8 cm³/rev [3.59 in³/rev]</p> <p>62 - 62.4 cm³/rev [3.81 in³/rev]</p> <p>Pos.4 - Shaft Extensions**</p> <p>SH - ø29.6 [1.165"] Spline W30x2x30x14x9g, M10</p> <p>QH - ø34.6 [1.36"] Spline W35x2x30x16x9g, M12</p> <p>Pos.5 - Port Size</p> <p>omit - 2xISO 6162-2 DN19, drain port M18x1.5</p> <p>2 - 2xG3/4, drain ports G1/2</p> <p>3 - 2xM27x2, drain ports M18x1.5</p> <p>4 - 2x1 1/16 -12 UN, drain ports 7/8-14 UNF</p> <p>5 - 2xSAE 3/4" PSI6000, drain port 7/8-14 UNF</p> <p>9 - 2xISO 6162-2 DN19, drain port G1/2</p> <p>Pos.6 - Seal, Corrosion Resistant Seal Surface</p> <p>omit - NBR seal type material</p> <p>V - FKM seal type material</p> <p>Pos.7 - Integrated Valves</p> <p>See page 77÷78 for information about valves</p> <p>omit - None</p> <p>HR - Single anti-cavitation valve</p> <p>AR - Dual anti-cavitation valve</p> <p>PU - Purge valve - default - 6±2 l/min</p> <p>FLU - Flush valve - default - 6±2 l/min at 20 bar</p> <p>SAR - Single anti-cavitation and relief valve</p> <p>DAR - Dual anti-cavitation and relief valve</p> <p>DARP - Dual anti-cavitation, relief and purge valve, default flow - 6±2 l/min</p> <p>DARF - Dual anti-cavitation, relief and flush valve, default flow - 6±2 l/min at 20 bar</p> | <p>Pos.8 - Valve's Port for Single Valves</p> <p>omit - None</p> <p>A - Port A</p> <p>B - Port B</p> <p>Pos.9 - Pressure Setting of Integrated Valves</p> <p>omit - None</p> <p>x - <table border="1" style="display: inline-table; vertical-align: middle;"><tr><td>250</td><td>300</td><td>350</td></tr></table></p> <p>for more information see page 77÷78</p> <p>Pos.10 - Flow Setting of Integrated Valves</p> <p>omit - None</p> <p>Lx - For value - see page 77÷78</p> <p>Pos.11 - Special Features*</p> <p>omit - None</p> <p>R2S - Speed Sensor Two Directional (see page 79)</p> <p>R - Reverse Rotation (see page 81)</p> <p>Pos.12 - Paint and Coating</p> <p>omit - No paint or coating</p> <p>P - Painted</p> <p>PC - Corrosion protected paint</p> <p>If a painting option is required, the standard color is black-Alkyd-Styrenated Enamel, Black RAL 9005. Other color by customer's request.</p> <p>Pos.13 - Design Series</p> <p>omit - Factory specified</p> <p>**The permissible output torque for shafts must not be exceeded!</p> | 250 | 300 | 350 |
| 250 | 300 | 350 | | |

EXAMPLE

M A P W T 6 2 S H 2

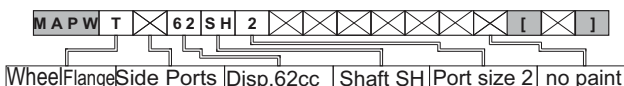

M A P W T 4 0 Q H 4 P

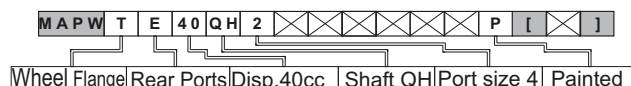



Hydraulic Pumps Type PAP28

Heavy Duty Axial Piston Pumps Fixed Displacement for open loop circuit

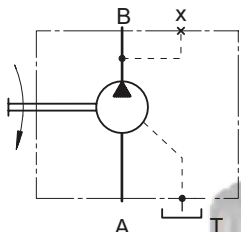

Symbols

- B Outlet port
- A Inlet port
- T Drain port

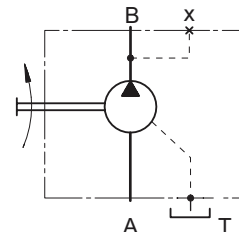

open drain line is always required

APPLICATION

- » Open loop circuit
- » Agricultural machines
- » Road building machines
- » Mining machinery
- » Food industry machines
- » Special vehicles

OPTIONS

- » Port options
- » Shaft options
- » High pressure ports

ADVANTAGES

- » Low noise
- » Low pulsation
- » Long service life
- » High power density

GENERAL

Displacement,	cm ³ /rev [in ³ /rev]	22.15÷28.47 [1.35÷1.74]
Max. Driving Speed,	RPM	3000
Max. Driving Torque,	Nm [lb-in]	158 [1400]
Max. Output,	kW [HP]	35 [47]
Max. Pressure,	bar [PSI]	350 [5080]
Max. Oil Flow,	l/min [GPM]	82 [21.7]
Min. Driving Speed,	RPM	500
Fluid	Mineral based- HLP(DIN 51524) or HM(ISO 6743/4)	
Temperature Range,	°C [°F]	-40÷82 [-40÷180]
Optimal Viscosity Range,	mm ² /s [SUS]	12÷68 [66÷311]
Filtration	ISO code 18/16/13 (Min. recommended fluid filtration of 10 micron)	

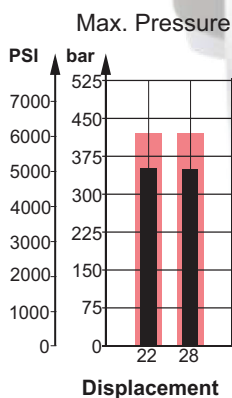

Intermittent values

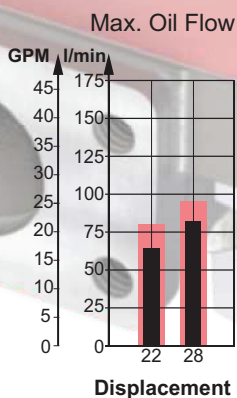

Continuous values

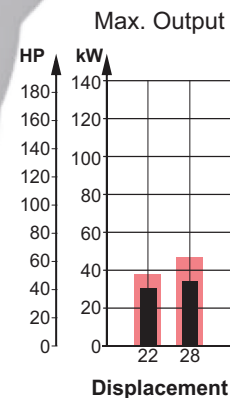

SECTION VIEW

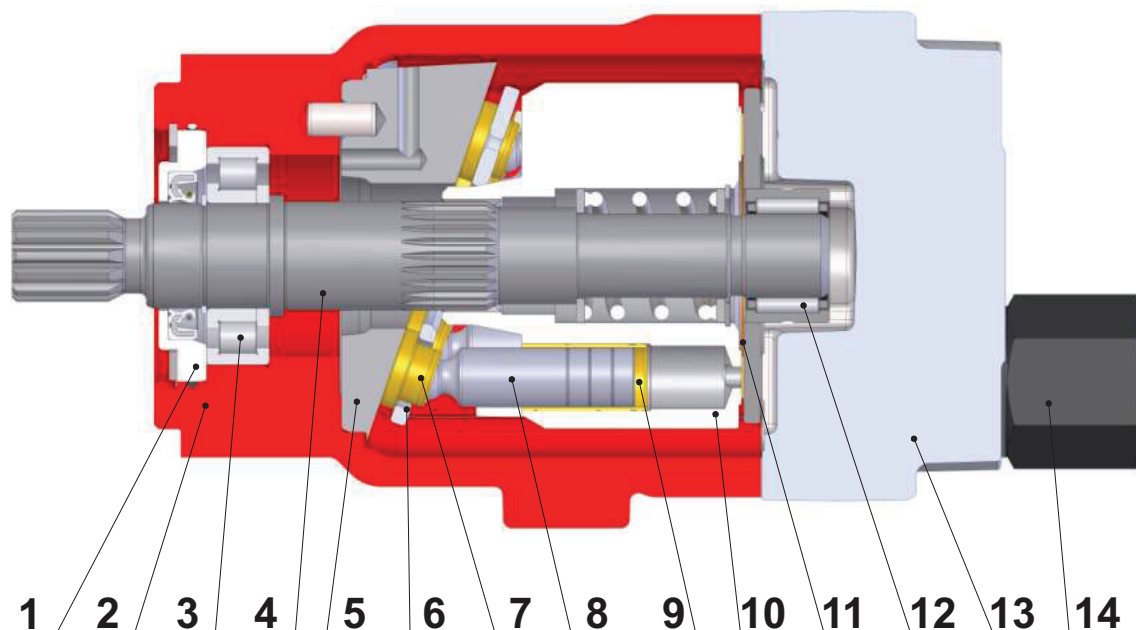

1. Front cover
2. Cast iron body
3. Robust radial - axial roller bearing
4. Hardened shaft
5. Solid swash plate
6. Retainer plate
7. Improved piston shoes
8. Improved pistons
9. Brass bushings
10. Hardened steel cylinder block
11. Bimetal distributor
12. Needle bearing
13. Solid end cover
14. Part of hydraulic system helps reduces pump noise and vibration

The main advantages of the heavy duty swash plate PAP pumps design over the typical pumps are:

- Special hydraulic system reducing the levels of noise and vibration created by the pump.
- Lower pulsations during operation.

In comparison with the bent axis and the gear pumps, the swash plate type is in general considered to have higher reliability.

SPECIFICATION DATA



Type		PAP 22	PAP 28
Displacement, cm ³ /rev[in ³ /rev]		22.15 [1.35]	28.47 [1.74]
Max. Driving Speed, Cont. [RPM]		3000	3000
	Int.*	3400	3400
Max. Driving Torque,*** Cont. Nm [lb-in]		123 [1090]	158 [1400]
	Int.**	148 [1310]	190 [1680]
Output, kW [HP]	Cont.	30 [40.2]	35 [47]
	Int.**	38 [51]	48 [64.4]
Max. Pressure, bar [PSI]	Cont.	350 [5080]	350 [5080]
	Int.**	420 [6100]	420 [6100]
	Peak	450 [6527]	450 [6527]
Max. Oil Flow, l/min [GPM]	Cont.	64 [16.9]	82 [21.7]
	Int.*	70 [18.5]	90 [23.8]
Permissible Shaft Load			
max Axial**** N[lb]		Fa=1300 [292]	
max Radial**** N[lb]		Fr=2200 [495]	
Min. Speed, [RPM]		500	
Max. Pressure in Drain Line, bar [PSI]		5 [70] open drain line is always required	
Weight, kg [lb]		12.80 [28.22] for SAE-A flange	
		13.50 [29.76] for SAE-B flange	

Peak pressure is the highest allowable pressure, may occur for max. 1% of every minute;

* Intermittent speed (flow): for pressure up to 150[2200] bar[PSI];

** Intermittent load: the permissible values may occur for max. 10% of pump lifetime;

*** Theoretical torque;

**** The calculated max values are based on the optimal direction of the forces Fr, Fa and optimal position of the shaft.

1. The recommended output power for continuous operations should not be exceeded.
2. Recommended filtration as per ISO 4406 cleanliness code 18/16/13 or better. This filtration corresponds to SAE AS 4059 8A/7B/7C. Nominal filtration - 10 micron or better.
3. Recommended a premium quality, anti-wear type mineral based hydraulic oil, HLP(DIN51524) or HM(ISO6743/4).
4. Recommended oil viscosity - 12...68 cSt or see page [84](#).
5. Recommended maximum system operating temperature - 82°[180°] C[F].
6. To ensure optimum life of the pump, fill it up with fluid prior to load it and run with moderate load and speed for about 10-15 minutes.

The constant values are approximate. Pump pressure and flow for a particular project are depending on the real operating conditions. For more detailed calculations please see efficiencies on page [75](#) and formulas on page [85](#).



OVERALL DIMENSIONS AND PORTS

Mounting Flange - Type **SAE-A**
Direction of Rotation **CW**(Right)

Port sizes **default, 5 and 9**
See the port sizes at the bottom of this page

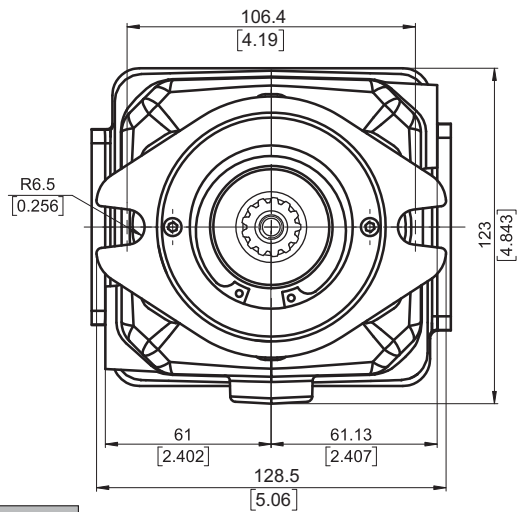
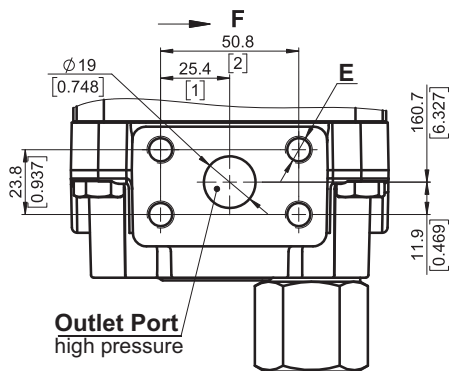
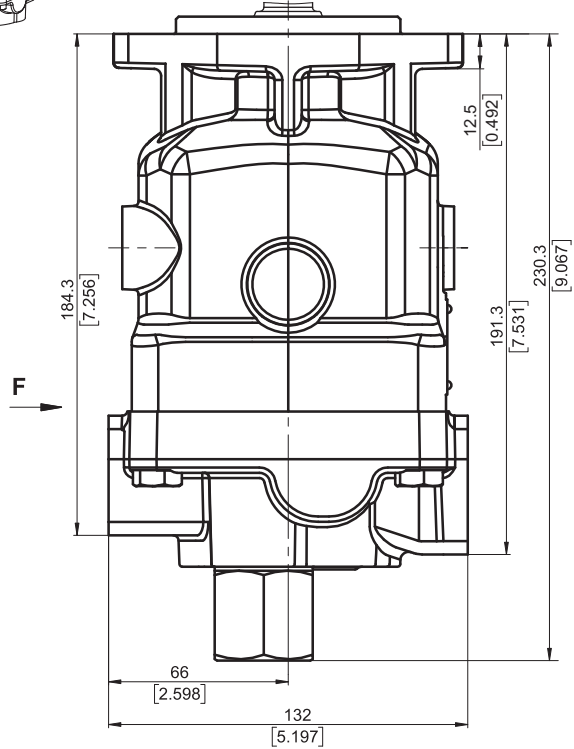
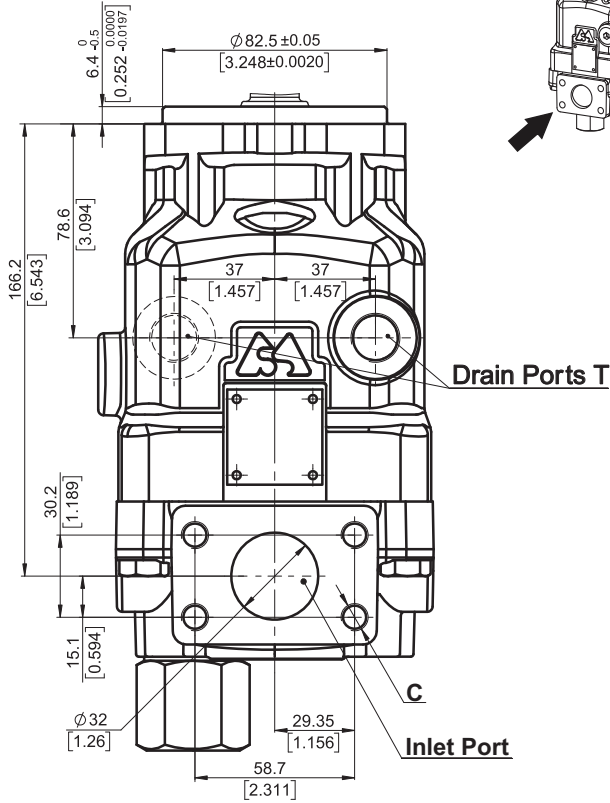
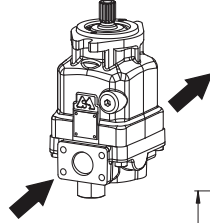
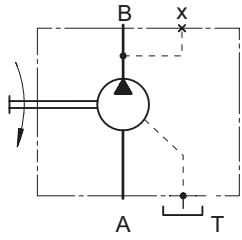

	Port Size		
	default	5	9
Inlet	ISO 6162-1 DN32	SAE J518 1 1/4 PSI3000	ISO 6162-1 DN32
Outlet	ISO 6162-2 DN19	SAE J518 3/4 PSI6000	ISO 6162-2 DN19
T	M18x1,5	7/8-14 UNF	G1/2
C	4xM10	4x7/16-14 UNC	4xM10
E	4xM10	4x3/8-16 UNC	4xM10

Shaft Mounting
see page 57

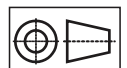

mm [in]



OVERALL DIMENSIONS AND PORTS

Mounting Flange - Type **SAE-A**
Direction of Rotation **CCW**(Left)

Port sizes **default, 5 and 9**
See the port sizes at the bottom of this page

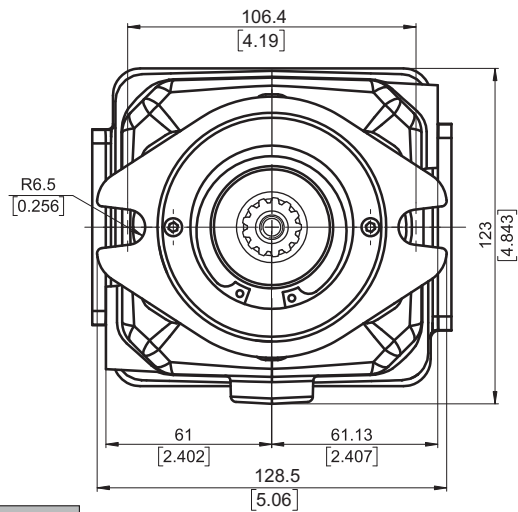
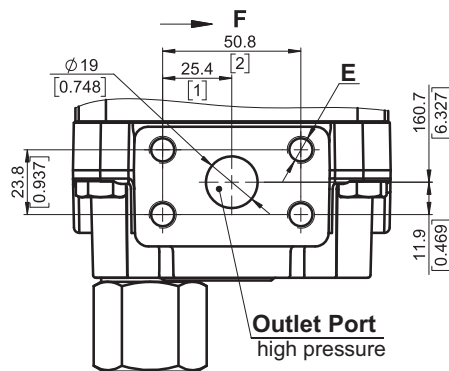
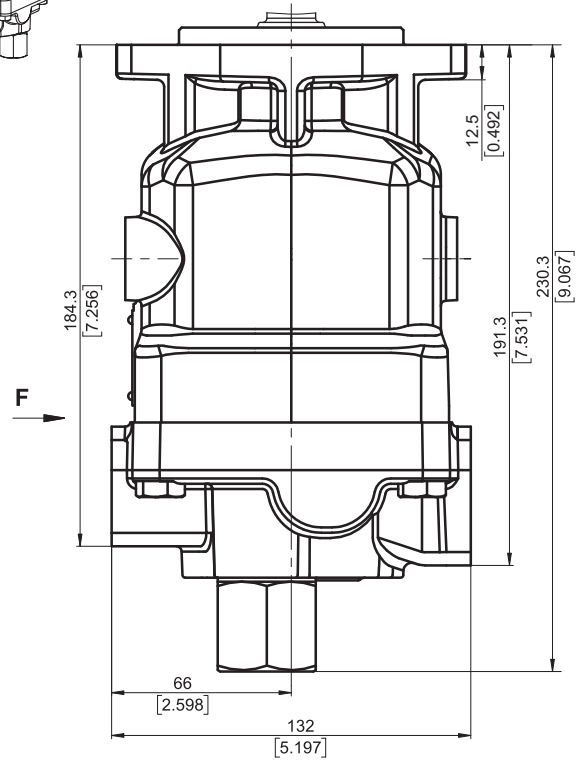
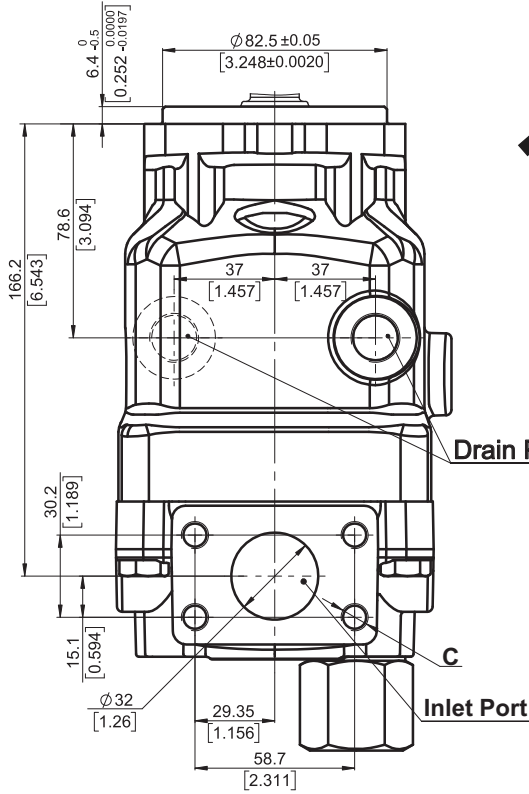
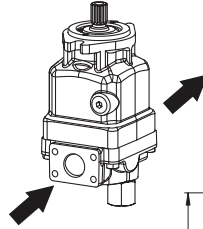
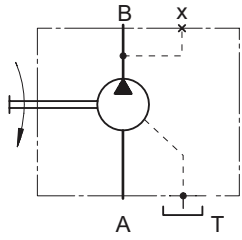

	Port Size		
	default	5	9
Inlet	ISO 6162-1 DN32	SAE J518 1 1/4 PSI3000	ISO 6162-1 DN32
Outlet	ISO 6162-2 DN19	SAE J518 3/4 PSI6000	ISO 6162-2 DN19
T	M18x1,5	7/8-14 UNF	G1/2
C	4xM10	4x7/16-14 UNC	4xM10
E	4xM10	4x3/8-16 UNC	4xM10

Shaft Mounting see page 57

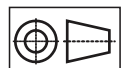

mm [in]



SHAFTS MOUNTING

Mounting Flange - Type **SAE-A**

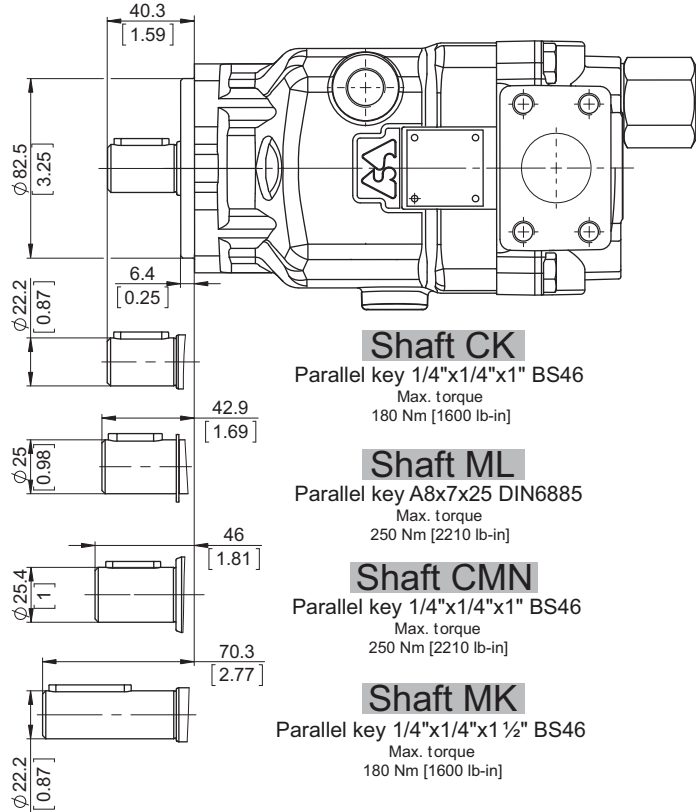
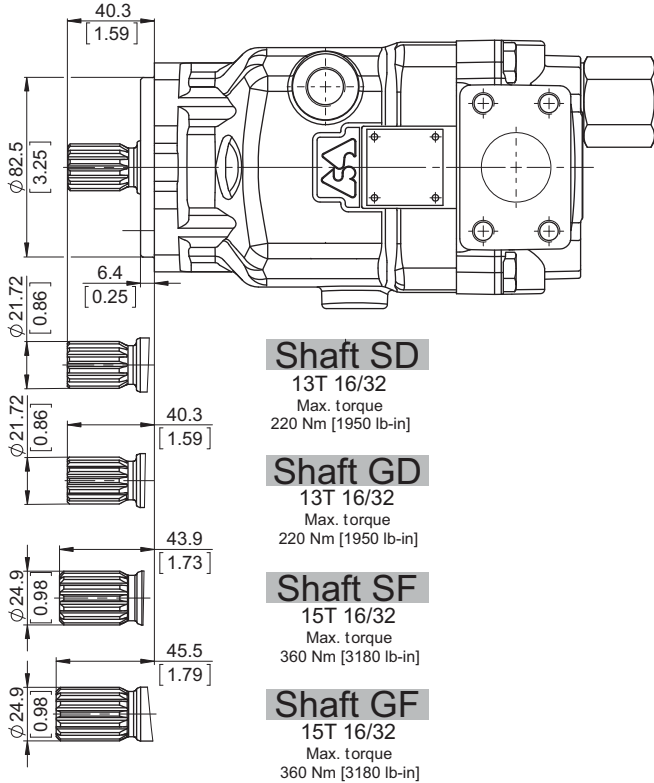

Shaft Dimensions
See Page [69+73](#)

PERMISSIBLE SHAFT LOAD

Permissible shaft load		
max Axial	N[lb]	Fa=1300 [292]
max Radial	N[lb]	Fr=2200 [495]

The calculated max values are based on the optimal direction of the forces Fr, Fa and optimal position of the shaft (see page [81](#)).

For more information, please, feel free to contact us.

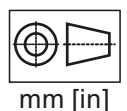



OVERALL DIMENSIONS AND PORTS

Mounting Flange - Type **SAE-B**
Direction of Rotation **CW**(Right)

Port sizes **default, 5 and 9**
See the port sizes at the bottom of this page

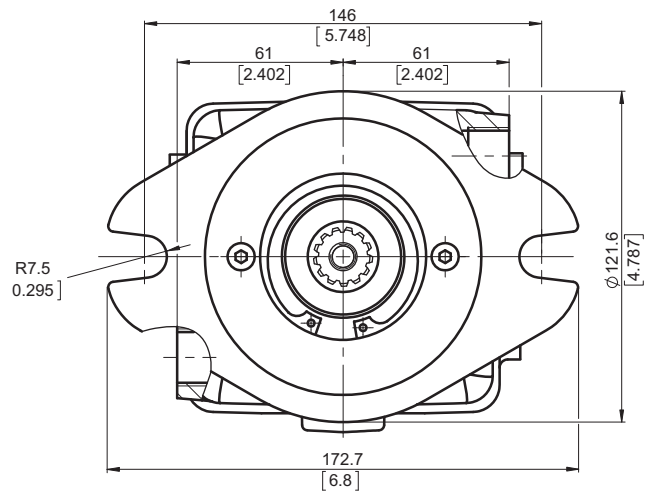
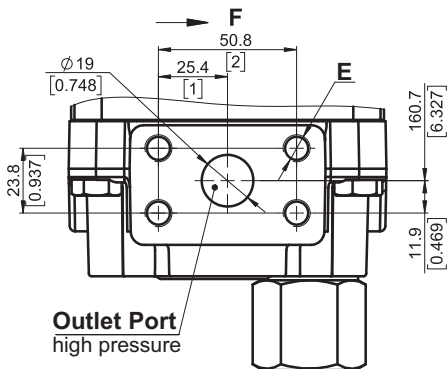
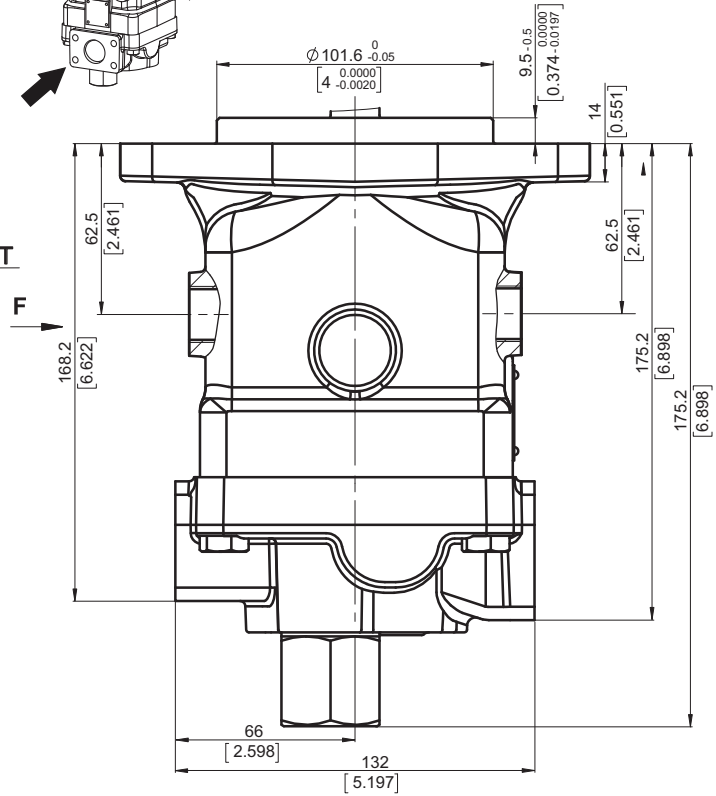
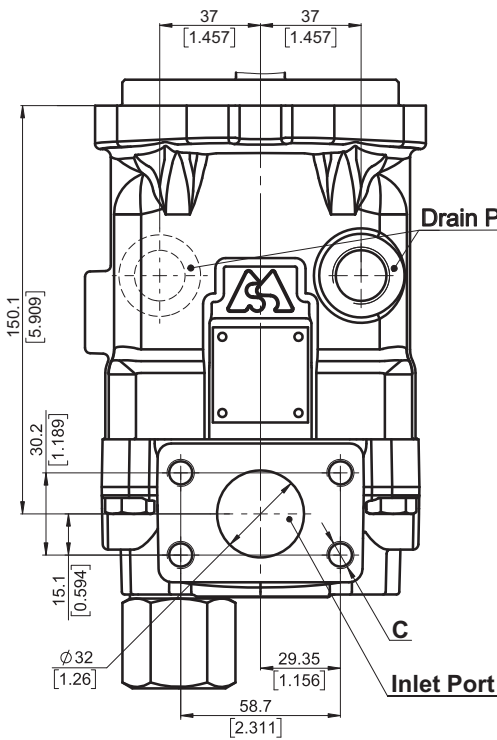
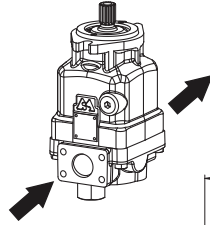
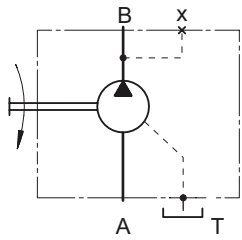

	Port Size		
	default	5	9
Inlet	ISO 6162-1 DN32	SAE J518 1¼ PSI3000	ISO 6162-1 DN32
Outlet	ISO 6162-2 DN19	SAE J518 3/4 PSI6000	ISO 6162-2 DN19
T	M18x1,5	7/8-14 UNF	G1/2
C	4xM10	4x7/16-14 UNC	4xM10
E	4xM10	4x3/8-16 UNC	4xM10

Shaft Mounting see page 60

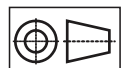

mm [in]



OVERALL DIMENSIONS AND PORTS

Mounting Flange - Type **SAE-B**
Direction of Rotation **CCW**(Left)

Port sizes **default, 5 and 9**
See the port sizes at the bottom of this page

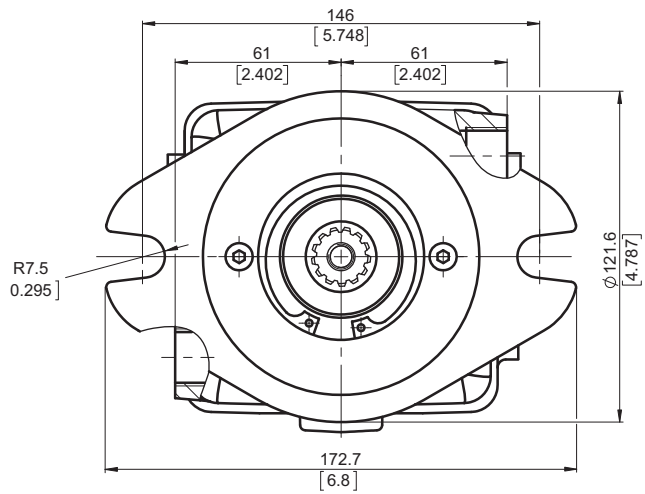
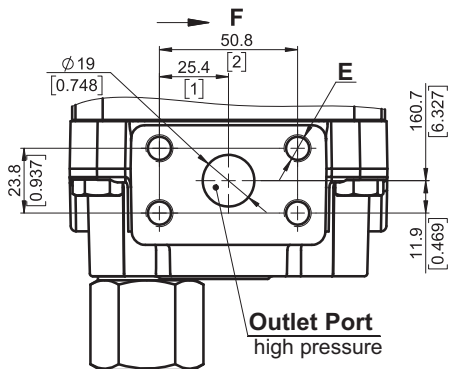
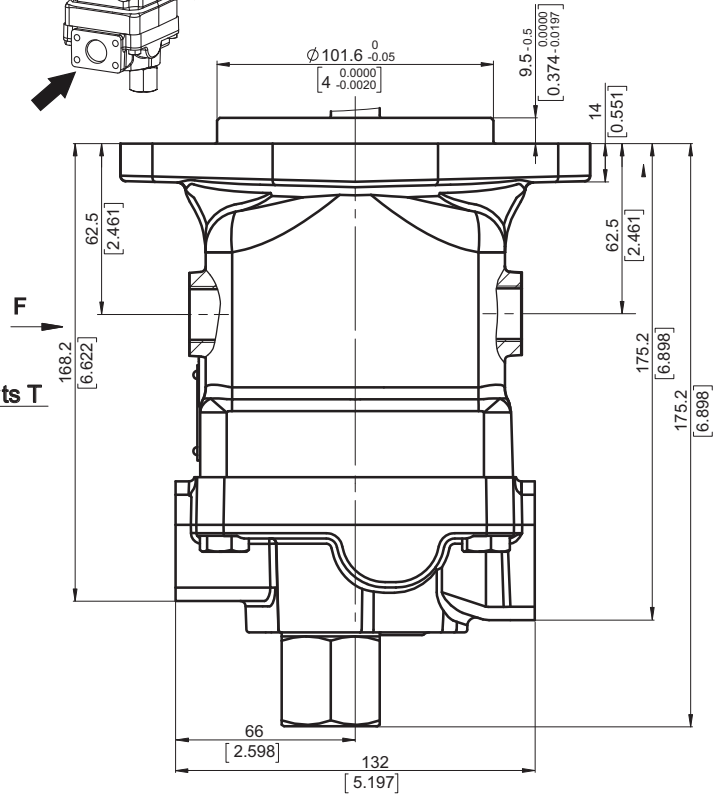
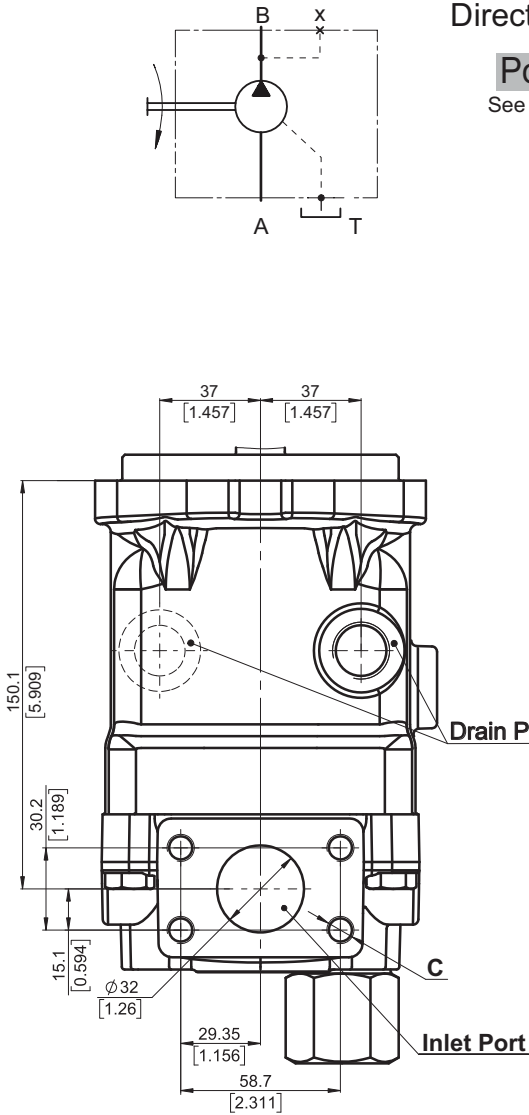
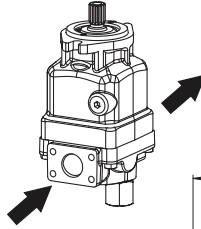

	Port Size		
	default	5	9
Inlet	ISO 6162-1 DN32	SAE J518 1¼ PSI3000	ISO 6162-1 DN32
Outlet	ISO 6162-2 DN19	SAE J518 3/4 PSI6000	ISO 6162-2 DN19
T	M18x1,5	7/8-14 UNF	G1/2
C	4xM10	4x7/16-14 UNC	4xM10
E	4xM10	4x3/8-16 UNC	4xM10

Shaft Mounting
see page 60

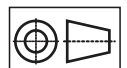

mm [in]



SHAFTS MOUNTING

Mounting Flange - Type SAE-B

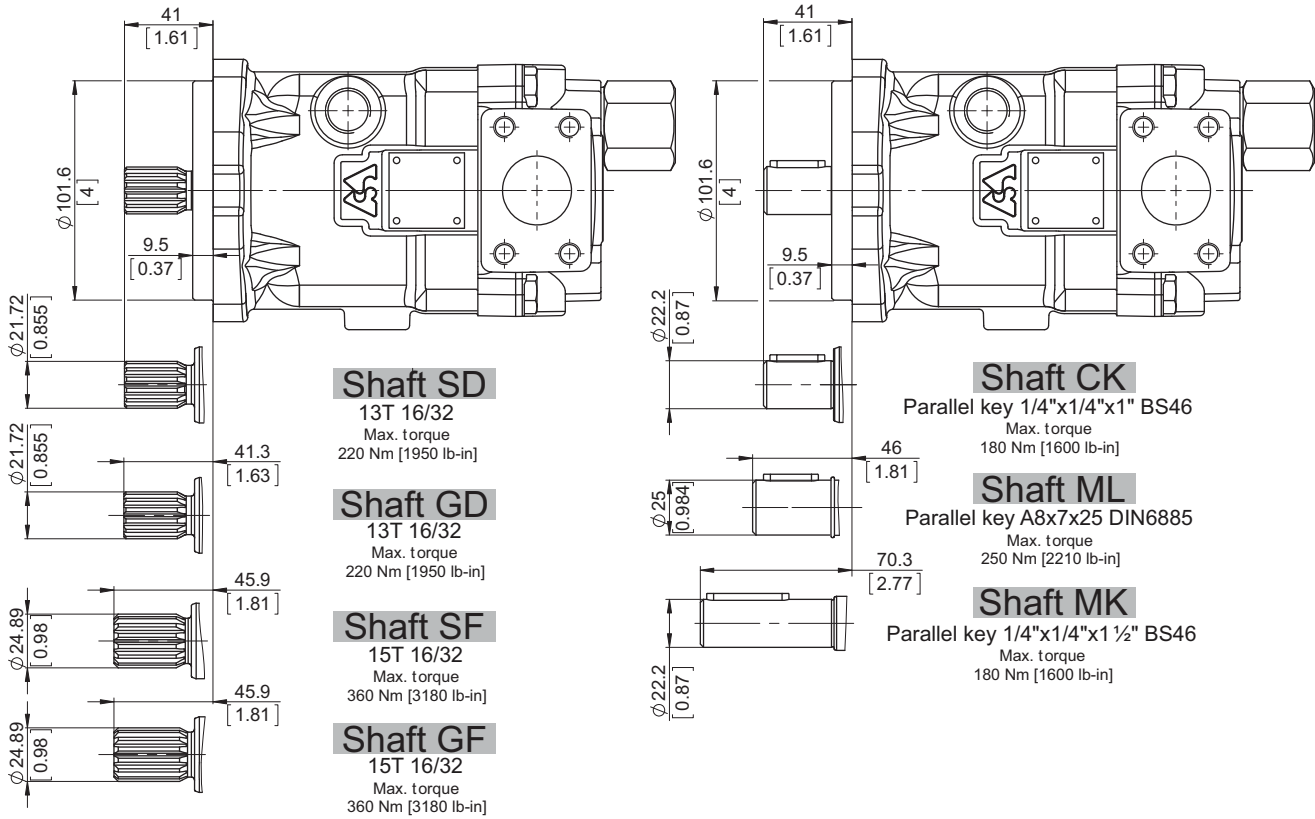

Shaft Dimensions
See Page [69+73](#)

PERMISSIBLE SHAFT LOAD

Permissible shaft load		
max Axial	N[lb]	Fa=1300 [292]
max Radial	N[lb]	Fr=2200 [495]

The calculated max values are based on the optimal direction of the forces Fr, Fa and optimal position of the shaft (see page [81](#)).

For more information, please, feel free to contact us.

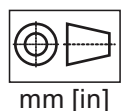



ORDERING CODE

	1	2	3	4	5	6	7	8	9	9	9
PAP									[]

Pos.1 - Mounting Flange

- A** - 2-Bolt flange, SAE A, spigot dia. 82.5 [3.25"], BC 106.35 [4.19"], Bolt Dia. 13.5 [0.53"]
- B** - 2-Bolt flange, SAE B, spigot dia. 101.6 [4"], BC 146 [5.748"], Bolt Dia. 14.3 [0.563"]

Pos.2 - Displacement Code

- 22** - 22.15 cm³/rev [1.35 in³/rev]
- 28** - 28.47 cm³/rev [1.74 in³/rev]

Pos.3 - Direction of Rotation

- R** - CW, Right direction
- L** - CCW, Left direction

Pos.4 - Shaft Extensions**

- SD** - ø21.72 [0.855"] Spline SAE 13T 16/32 DP, M8 thread
- GD** - ø21.72 [0.855"] Spline SAE 13T 16/32 DP, 5/16-18 UNC thread
- SF** - ø24.9 [0.98"] Spline SAE 15T 16/32, M8 thread
- GF** - ø24.9 [0.98"] Spline SAE 15T 16/32, 3/8-16UNC thread
- CK** - ø22.2 [7/8"] Straight, M8 thread
Parallel key 1/4"x1/4"x1" BS46
- MK** - ø22.2 [7/8"] Straight, M8 thread
Parallel key 1/4"x1/4"x1 1/2" BS46
- ML** - ø25 [0.984"] Straight, M8 thread
Parallel key A8x7x25 DIN6885
- CMN** - ø25.4 [1"] Straight, M8 thread
Parallel key 1/4"x1/4"x1" BS46
Shaft type CMN is available only for Pos.1 option A

Pos.5 - Port Size

- omit - Inlet ISO 6162-1 DN32, Outlet ISO 6162-2 DN19, metric thread, drain ports M18x1.5
- 5** - Inlet SAE J518 1 1/4" PSI3000, Outlet SAEJ518 3/4" PSI6000, sae thread, drain 7/8-14 UNF
- 9** - Inlet ISO 6162-1 DN32, Outlet ISO 6162-2 DN19, metric thread, drain ports G1/2

Pos.6 - Seal, Corrosion Resistant Seal Surface

- omit - NBR seal type material
- V** - FKM seal type material

Pos.7 - Special Features* see page 77

- omit - None
- R2S** - Speed Sensor Two Directional

Pos.8 - Paint and Coating

- omit - No paint or coating
- P** - Painted
- PC** - Painted corrosion protected paint

If a painting option is required, the standard color is black-Alkyd-Styrenated Enamel, Black RAL 9005. Other color by customer's request.

Pos.9 - Design Series

- omit - Factory specified

**The permissible output torque for shafts must not be exceeded!

EXAMPLE

PAPB28RSH5

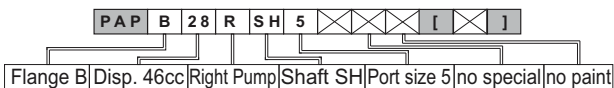

PAPA22LSDPS

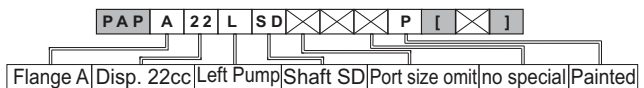



Hydraulic Pumps Type PAP62

Heavy Duty Axial Piston Pumps Fixed Displacement for open loop circuit

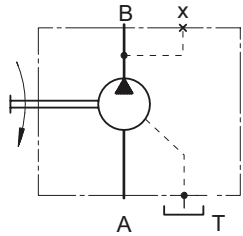

Symbols

- B Outlet port
- A Inlet port
- T Drain port

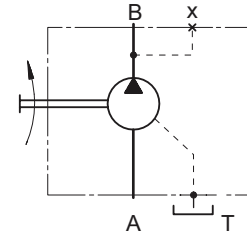

open drain line is always required

APPLICATION

- » Open loop circuit
- » Agricultural machines
- » Road building machines
- » Mining machinery
- » Food industry machines
- » Special vehicles

OPTIONS

- » Port options
- » Shaft options
- » High pressure ports

ADVANTAGES

- » Low noise
- » Low pulsation
- » Long service life
- » High power density

GENERAL

Displacement,	cm ³ /rev [in ³ /rev]	36.16÷62.4 [2.21÷3.81]
Max. Driving Speed,	RPM	2800
Max. Driving Torque,	Nm [lb-in]	318 [2814]
Max. Output,	kW [HP]	56 [77.8]
Max. Pressure,	bar [PSI]	350 [5080]
Max. Oil Flow,	l/min [GPM]	132 [35]
Min. Driving Speed,	RPM	500
Fluid	Mineral based- HLP(DIN 51524) or HM(ISO 6743/4)	
Temperature Range,	°C [°F]	-40÷82 [-40÷180]
Optimal Viscosity Range,	mm ² /s [SUS]	12÷68 [66÷311]
Filtration	ISO code 18/16/13 (Min. recommended fluid filtration of 10 micron)	

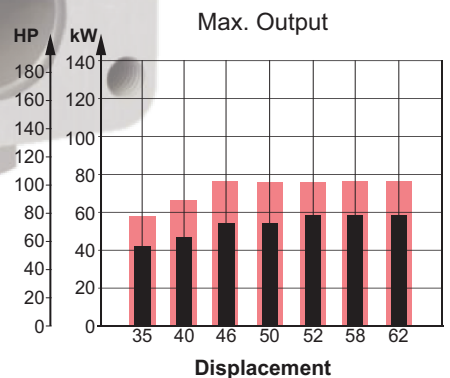
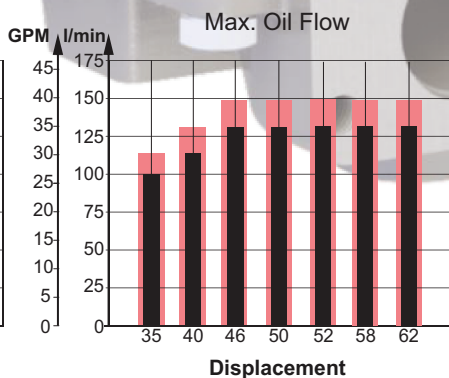
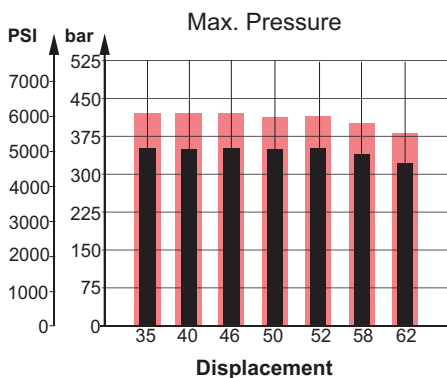

Intermittent values

Continuous values



SECTION VIEW

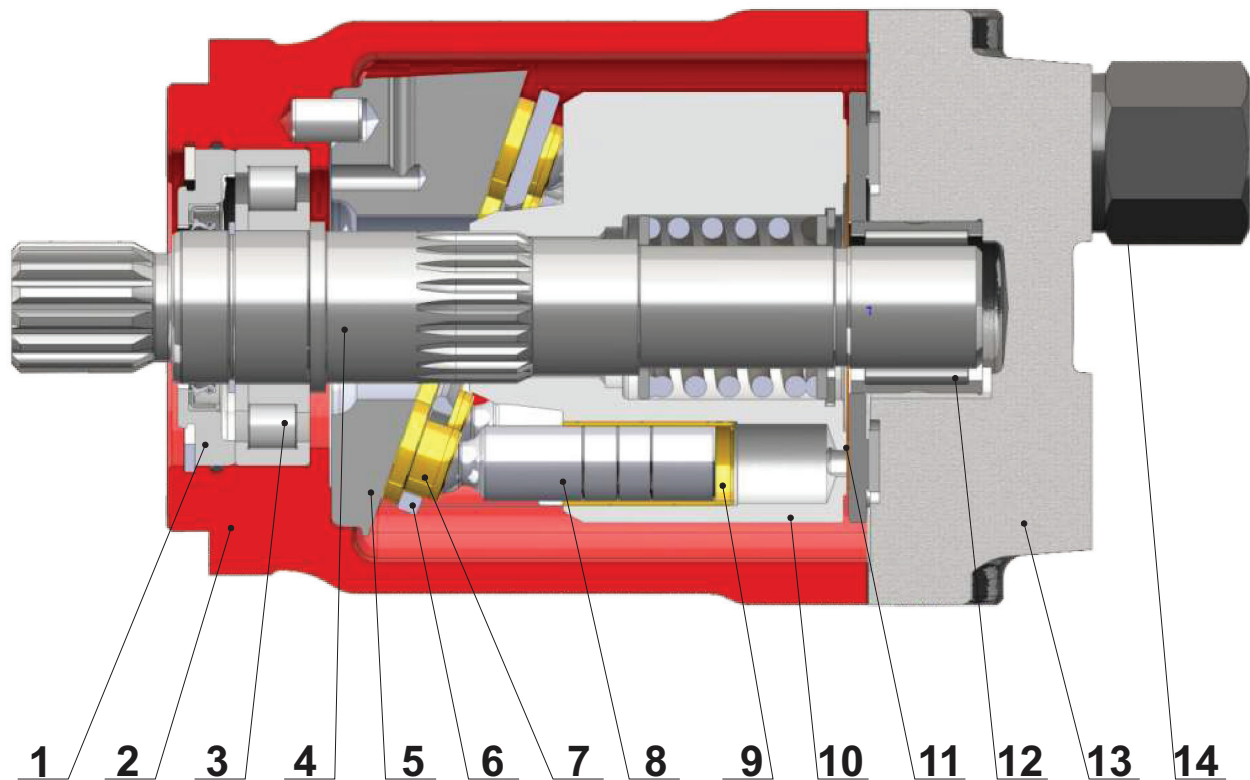

1. Front cover
2. Cast iron body
3. Robust radial - axial roller bearing
4. Hardened shaft
5. Solid swash plate
6. Retainer plate
7. Improved piston shoes
8. Improved pistons
9. Brass bushings
10. Hardened steel cylinder block
11. Bimetal distributor
12. Needle bearing
13. Solid end cover
14. Part of hydraulic system helps reduces pump noise and vibration

The main advantages of the heavy duty swash plate PAP pumps design over the typical pumps are:

- Special hydraulic system reducing the levels of noise and vibration created by the pump.
- Lower pulsations during operation.

In comparison with the bent axis and the gear pumps, the swash plate type is in general considered to have higher reliability.

SPECIFICATION DATA

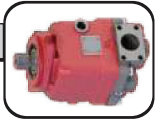

Type		PAP 35	PAP 40	PAP 46	PAP 50	PAP 52	PAP 58	PAP 62	
Displacement, cm ³ /rev[in ³ /rev]		36.16 [2.21]	41.59 [2.54]	47.13 [2.88]	49.94 [3.05]	51.95 [3.17]	58.8 [3.59]	62.4 [3.81]	
	Max. Driving Speed, Cont. [RPM]	2800	2800	2800	2500	2400	2130	2000	
	Int.*	3150	3150	3150	2800	2700	2390	2250	
Max. Driving Torque,*** Nm [lb-in]	Cont.	202 [1789]	232 [2053]	263 [2328]	278 [2460]	290 [2566]	320 [2832]	318 [2814]	
	Int.**	242 [2142]	278 [2460]	315 [2788]	326 [2885]	347 [3071]	375 [3320]	377 [3337]	
Output, kW [HP]	Cont.	41 [55]	47 [63]	54 [72.5]	54 [72.5]	58 [77.8]	58 [77.8]	58 [77.8]	
	Int.**	58 [78]	67 [90]	77 [198]	77 [198]	77 [198]	77 [198]	77 [198]	
Max. Pressure, bar [PSI]	Cont.	350 [5080]	350 [5080]	350 [5080]	350 [5080]	350 [5080]	340 [4930]	320 [4640]	
	Int.**	420 [6100]	420 [6100]	420 [6100]	410 [5950]	420 [6100]	400 [5800]	380 [5510]	
	Peak	450 [6527]	450 [6527]	450 [6527]	450 [6527]	450 [6527]	440 [6381]	410 [5950]	
Max. Oil Flow, l/min [GPM]	Cont.	100 [26.4]	116 [30]	132 [34.9]	132 [34.9]	132 [34.9]	132 [34.9]	132 [34.9]	
	Int.*	114 [30]	131 [35]	148 [39]	148 [39]	148 [39]	148 [39]	148 [39]	
Permissible Shaft Load max Axial**** N[lb]								Fa=2000 [450]	
	max Radial**** N[lb]							Fr=3600 [810]	
Min. Speed, [RPM]								500	
Max. Pressure in Drain Line, bar [PSI]								5 [70] open drain line is always required	
Weight, kg [lb]								18.14 [40]	

Peak pressure is the highest allowable pressure, may occur for max. 1% of every minute;

* Intermittent speed (flow): for pressure up to 150[2200] bar[PSI];

** Intermittent load: the permissible values may occur for max. 10% of pump lifetime;

*** Theoretical torque;

**** The calculated max values are based on the optimal direction of the forces Fr, Fa and optimal position of the shaft.

1. The recommended output power for continuous operations should not be exceeded.
2. Recommended filtration as per ISO 4406 cleanliness code 18/16/13 or better. This filtration corresponds to SAE AS 4059 8A/7B/7C. Nominal filtration - 10 micron or better.
3. Recommended a premium quality, anti-wear type mineral based hydraulic oil, HLP(DIN51524) or HM(ISO6743/4).
4. Recommended oil viscosity - 12...68 cSt or see page [84](#).
5. Recommended maximum system operating temperature - 82°[180°] C[F].
6. To ensure optimum life of the pump, fill it up with fluid prior to load it and run with moderate load and speed for about 10-15 minutes.

The constant values are approximate. Pump pressure and flow for a particular project are depending on the real operating conditions. For more detailed calculations please see efficiencies on page [75](#) and formulas on page [85](#).

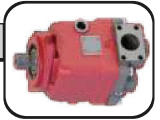

OVERALL DIMENSIONS AND PORTS

Direction of Rotation **CW**(Right)

Port sizes **default** and **5**

See the port sizes at the bottom of this page

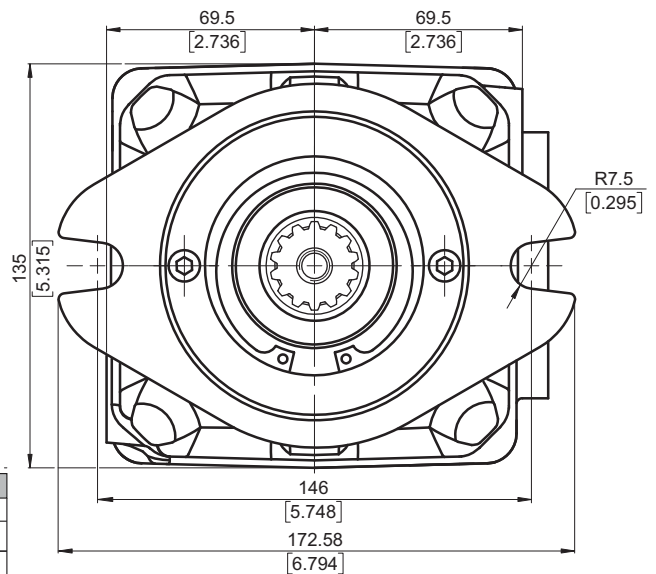
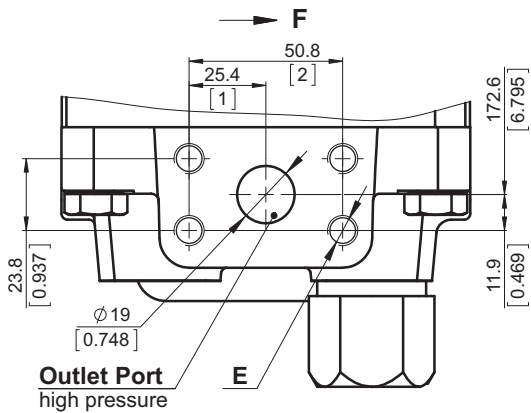
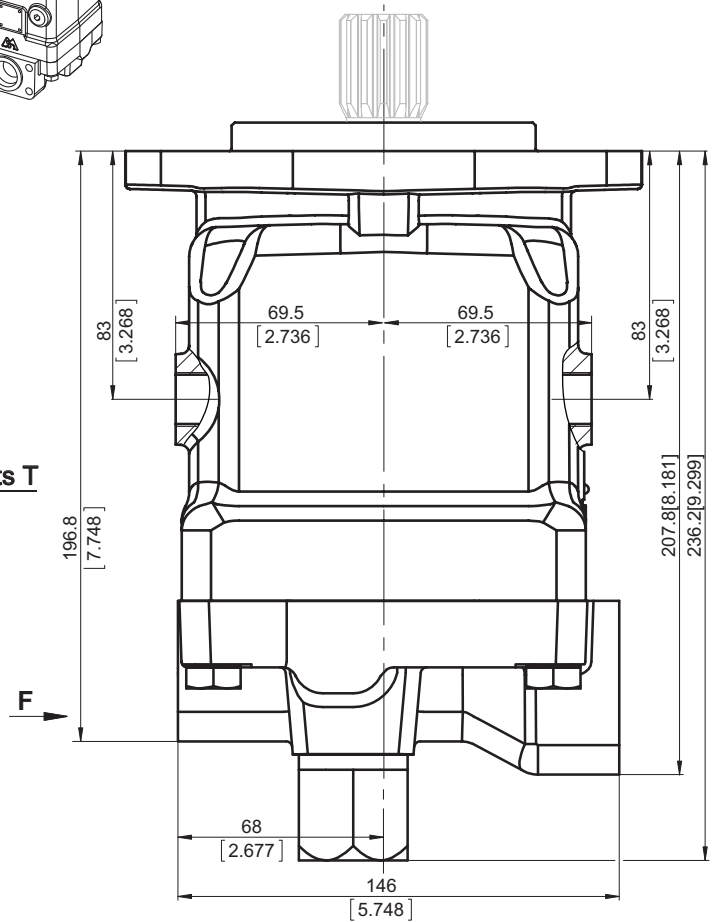
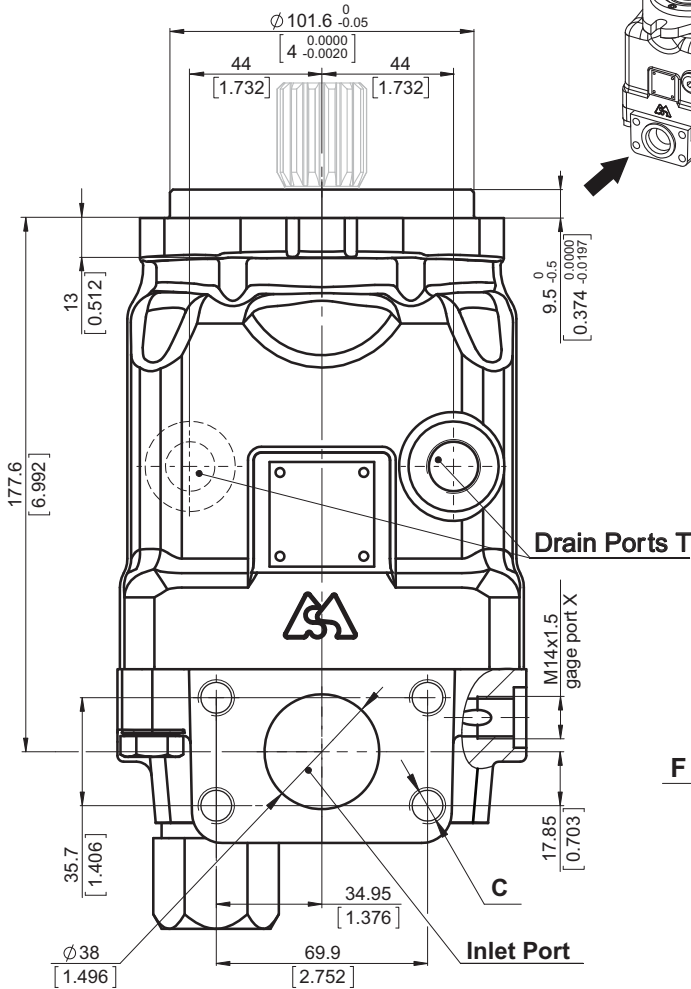
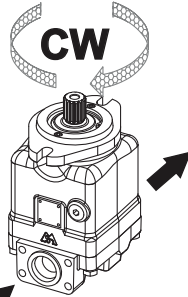
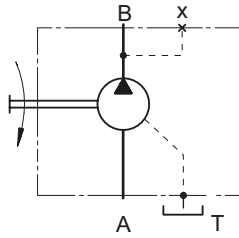

	Port Size		
	default	5	9
Inlet	ISO 6162-1 DN38	SAE J518 1 1/2 PSI3000	ISO 6162-1 DN38
Outlet	ISO 6162-2 DN19	SAE J518 3/4 PSI6000	ISO 6162-2 DN19
T	M18x1,5	7/8-14 UNF	G1/2
C	4xM12	4x1/2-13 UNC	4xM12
E	4xM10	4x3/8-16 UNC	4xM10

Shaft Mounting see page 67

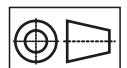

mm [in]

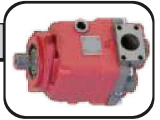

OVERALL DIMENSIONS AND PORTS

Direction of Rotation **CCW**(Left)

Port sizes **default and 5**

See the port sizes at the bottom of this page

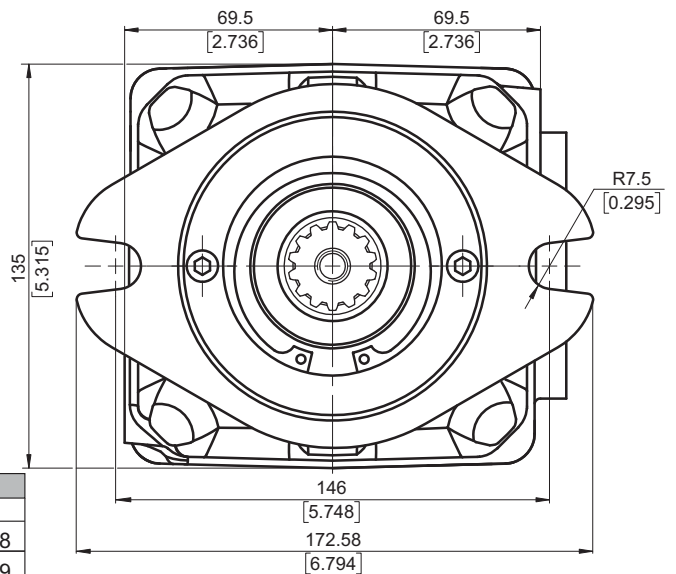
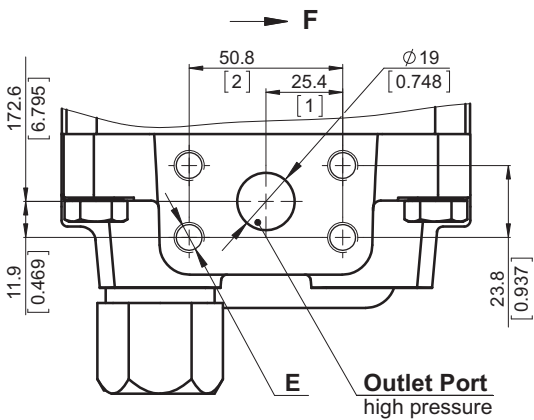
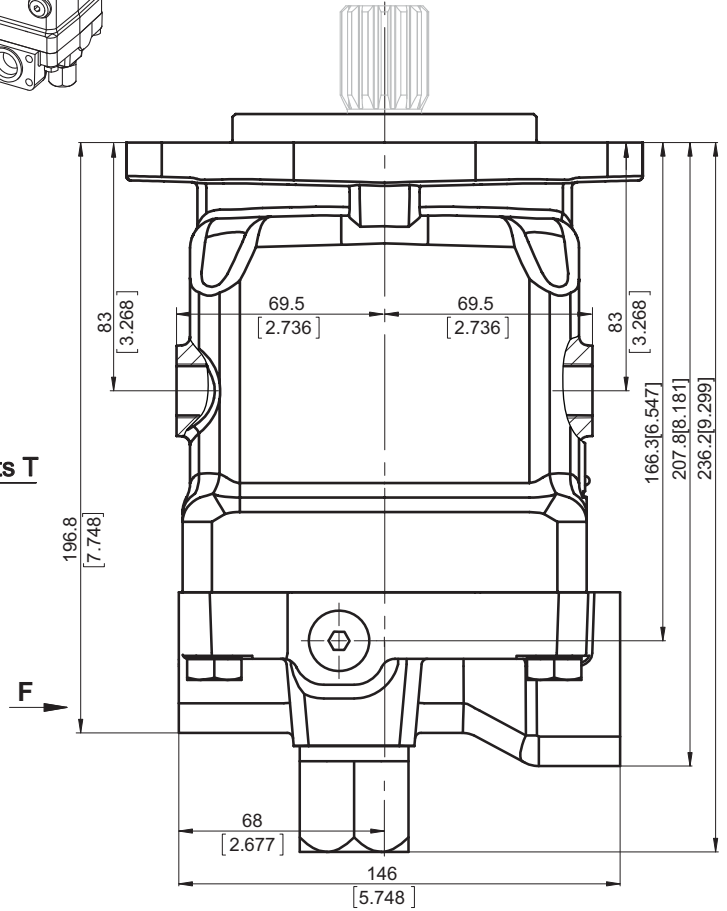
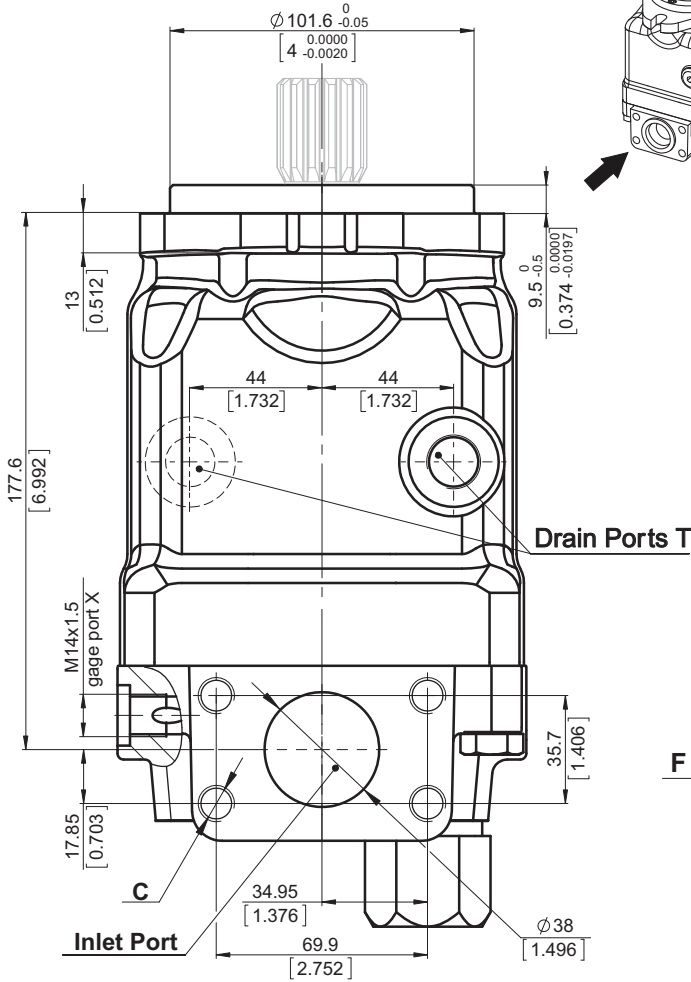
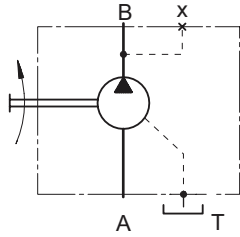

	Port Size		
	default	5	9
Inlet	ISO 6162-1 DN38	SAE J518 1 1/2 PSI3000	ISO 6162-1 DN38
Outlet	ISO 6162-2 DN19	SAE J518 3/4 PSI6000	ISO 6162-2 DN19
T	M18x1,5	7/8-14 UNF	G1/2
C	4xM12	4x1/2-13 UNC	4xM12
E	4xM10	4x3/8-16 UNC	4xM10

Shaft Mounting
see next page

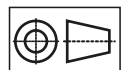

mm [in]



SHAFTS MOUNTING

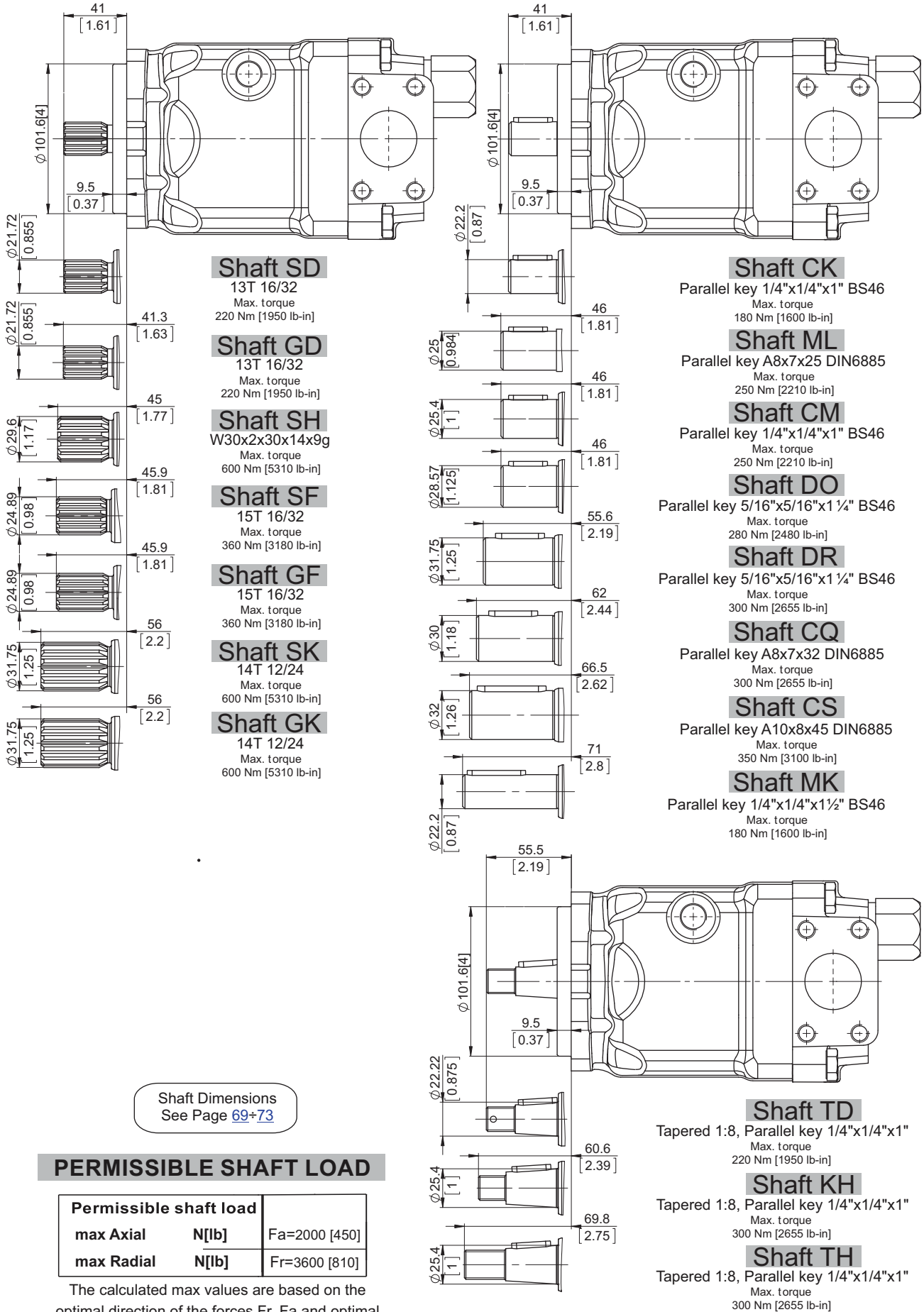

Shaft Dimensions
See Page 69+73

PERMISSIBLE SHAFT LOAD

Permissible shaft load		
max Axial	N[lb]	Fa=2000 [450]
max Radial	N[lb]	Fr=3600 [810]

The calculated max values are based on the optimal direction of the forces Fr, Fa and optimal position of the shaft (see page 81).

For more information, please, feel free to contact us.

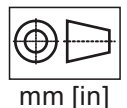



ORDERING CODE

	1	2	3	4	5	6	7	8	9	9	9
PAP									[]

Pos.1 - Mounting Flange

B - SAE B - 2-Bolt flange
spigot diam. 101.6 [4"] - BC 146 [5.75"]

Pos.2 - Displacement Code

- 35** - 36.16 cm³/rev [2.21 in³/rev]
- 40** - 41.59 cm³/rev [2.54 in³/rev]
- 46** - 47.13 cm³/rev [2.88 in³/rev]
- 50** - 49.94 cm³/rev [3.05 in³/rev]
- 52** - 51.95 cm³/rev [3.17 in³/rev]
- 58** - 58.8 cm³/rev [3.59 in³/rev]
- 62** - 62.4 cm³/rev [3.81 in³/rev]

Pos.3 - Direction of Rotation

- R** - CW, Right direction
- L** - CCW, Left direction

Pos.4 - Shaft Extensions**

- SD** - ø21.72 [0.855"] Spline SAE 13T 16/32 DP, M8
- GD** - ø21.72 [0.855"] Spline SAE 13T 16/32 DP, 5/16-18 UNC thread
- SF** - ø24.9 [0.98"] Spline SAE 15T 16/32, M8
- GF** - ø24.9 [0.98"] Spline SAE 15T 16/32, 3/8-16UNC
- SH** - ø29.6 [1.165"] Spline W30x2x30x14x9g DIN, M10 thread
- SK** - ø31.75 [1.25"] Spline SAE 14T 12/24 DP, M10
- GK** - ø31.75 [1.25"] Spline SAE 14T 12/24 DP, 7/16-14UNC thread
- CK** - ø22.2 [7/8"] Straight, M8 thread
Parallel key 1/4"x1/4"x1" BS46
- MK** - ø22.2 [7/8"] Straight, M8 thread
Parallel key 1/4"x1/4"x1½" BS46
- ML** - ø25 [0.984"] Straight, M8 thread
Parallel key A8x7x25 DIN6885
- CM** - ø25.4 [1"] Straight, M8 thread
Parallel key 1/4"x1/4"x1" BS46
- DO** - ø28.75 [1.125"] Straight, 3/8-16UNC
Parallel key 5/16"x5/16"x1¼" BS46
- CQ** - ø30 [1.181"] Straight, M8 thread
Parallel key A8x7x32 DIN6885
- DR** - ø31.75 [1.25"] Straight, 3/8-16UNC
Parallel key 5/16"x5/16"x1¼" BS46
- CS** - ø32 [1.26"] Straight, M8 thread
Parallel key A10x8x45 DIN6885
- TD** - ø22.22 [7/8"] Tapered 1:8 [125:1000],
Parallel key 1/4"x1/4"x1", 5/8-18 UNF
- TH** - ø25.4 [1"] Tapered 1:8 [125:1000],
Parallel key 1/4"x1/4"x1", 3/4-16 UNF
- KH** - ø25.4 [1"] Tapered 1:8 [125:1000],
Parallel key 1/4"x1/4"x1", M16x1.5

Pos.5 - Port Size

- omit - Inlet ISO 6162-1 DN38, Outlet ISO 6162-2 DN19, metric thread, drain ports M18x1.5
- 5** - Inlet SAE J518 1½" PSI3000, Outlet SAEJ518 3/4" PSI6000, sae thread, drain 7/8-14 UNF
- 9** - Inlet ISO 6162-1 DN38, Outlet ISO 6162-2 DN19, metric thread, drain ports G1/2

Pos.6 - Seal, Corrosion Resistant Seal Surface

- omit - NBR seal type material
- V** - FKM seal type material

Pos.7 - Special Features* see page 77

- omit - None
- R2S** - Speed Sensor Two Directional

Pos.8 - Paint and Coating

- omit - No paint or coating
- P** - Painted
- PC** - Painted corrosion protected paint

If a painting option is required, the standard color is black-Alkyd-Styrenated Enamel, Black RAL 9005. Other color by customer's request.

Pos.9 - Design Series

- omit - Factory specified

**The permissible output torque for shafts must not be exceeded!

EXAMPLE

PAPB46RSH5

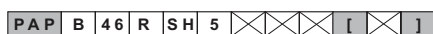

Flange B | Disp. 46cc | Right Pump | Shaft SH | Port size 5 | no special | no paint

PAPB40LSD5PS

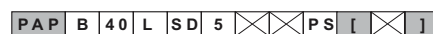

Flange B | Disp. 40cc | Left Pump | Shaft SD | Port size 5 | no special | Painted

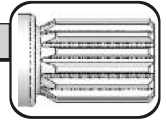

SHAFT TYPES AND DIMENSIONS

SD

ø21.72 [0.855], M8 thread
13T 16/32 DP splined ANSI B92.1-1970
 Max. torque 220 Nm [1950 lb-in]

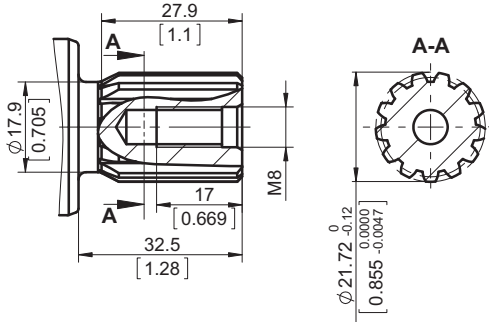

GD

ø21.72 [0.855], 5/16-18 UNC thread
13T 16/32 DP splined ANSI B92.1-1970
 Max. torque 220 Nm [1950 lb-in]

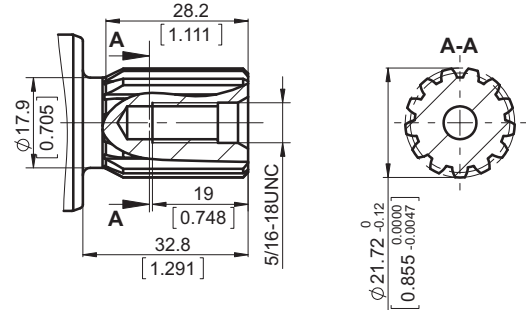

SF

ø24.89 [0.98], M8 thread
15T 16/32 DP splined ANSI B92.1-1970
 Max. torque 330 Nm [3180 lb-in]

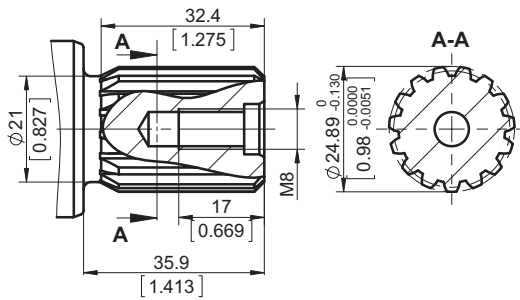

GF

ø24.89 [0.98], 3/8-16 UNC thread
15T 16/32 DP splined ANSI B92.1-1970
 Max. torque 310 Nm [3180 lb-in]

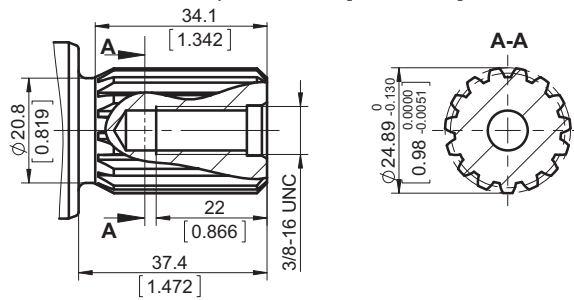

SH

ø29.6 [1.165], M10 thread
W30x2x30x14x9g splined DIN 5480
 Max. torque 500 Nm [5310 lb-in]

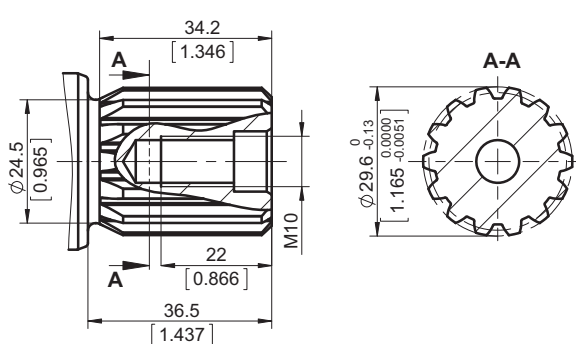

SK

ø31.75 [1.25], M10 thread
14T 12/24 DP splined ANSI B92.1-1970
 Max. torque 600 Nm [5310 lb-in]

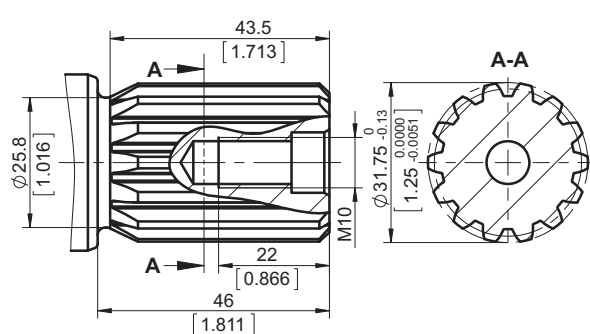

The required max. torque must not be exceeded

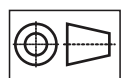

mm [in]

SHAFT TYPES AND DIMENSIONS

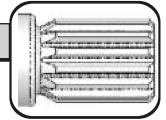

GK

$\phi 31.75$ [1.25], 7/16-14 UNC thread
14T 12/24 DP splined ANSI B92.1-1970
Max. torque 600 Nm [5310 lb-in]

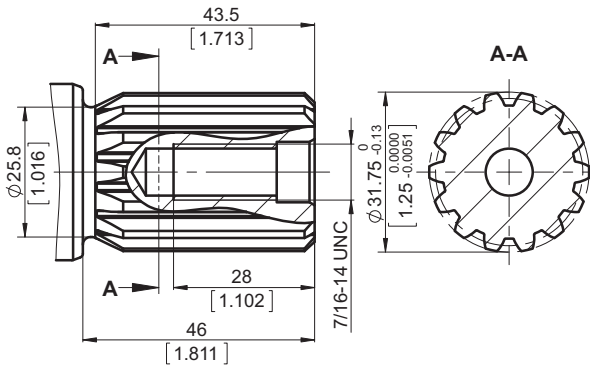

SP

$\phi 34.5$ [1.358], M12 thread
21T 16/32 DP splined ANSI B92.1-1970
Max. torque 1085 Nm [9600 lb-in]

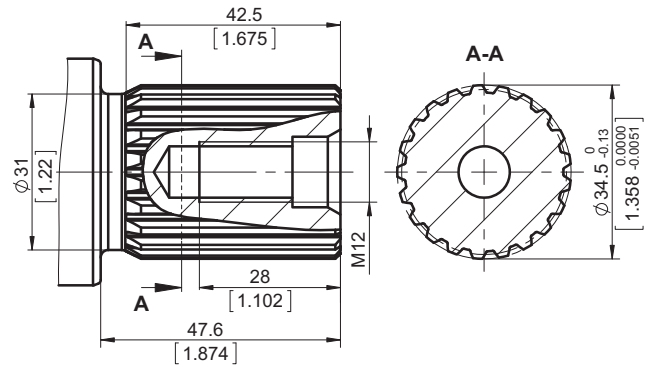

QH

$\phi 34.6$ [1.36], M12 thread
W35x2x30x16x9g splined DIN 5480
Max. torque 1085 Nm [9600 lb-in]

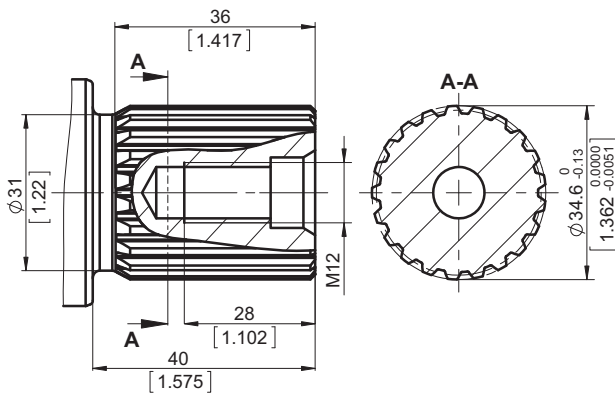

SR

$\phi 37.6$ [1.5], M12 thread
23T 16/32 DP splined ANSI B92.1-1970
Max. torque 1300 Nm [11500 lb-in]

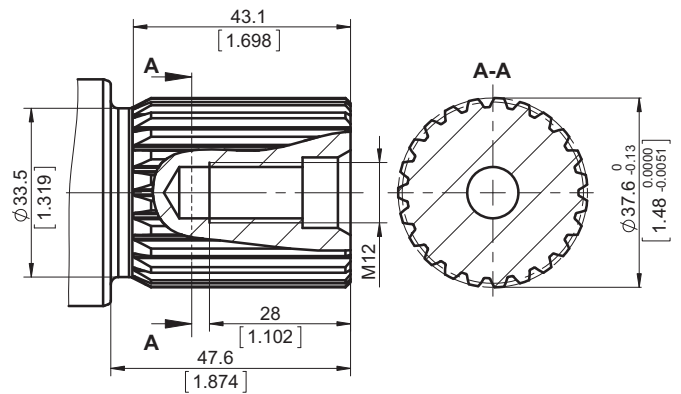

ST

$\phi 39.6$ [1.559], M12 thread
W40x2x30x18x9g splined DIN 5480
Max. torque 1400 Nm [12400 lb-in]

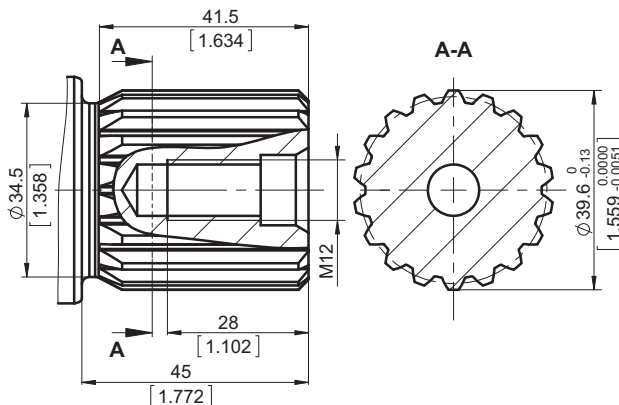

GU

$\phi 44.43$ [1.75], 3/8-16 UNC thread
13T 8/16 DP splined ANSI B92.1-1970
Max. torque 1400 Nm [17700 lb-in]

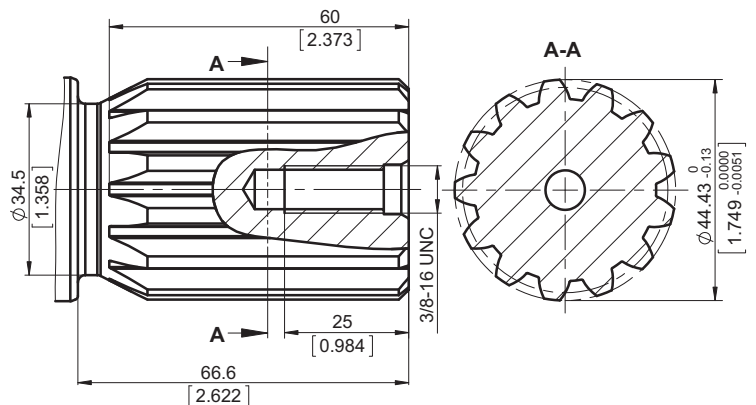

The required max. torque
must not be exceeded

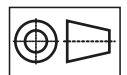

mm [in]

SHAFT TYPES AND DIMENSIONS

CK

$\varnothing 22.2$ [7/8] straight, M8 thread
Parallel key $1/4 \times 1/4 \times 1$ " BS46
Max. torque 180 Nm [1600 lb-in]

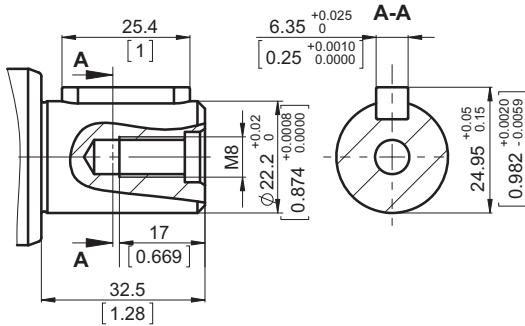

MK

$\varnothing 22.2$ [7/8] straight, M8 thread
Parallel key $1/4 \times 1/4 \times 1/2$ " BS46
Max. torque 180 Nm [1600 lb-in]

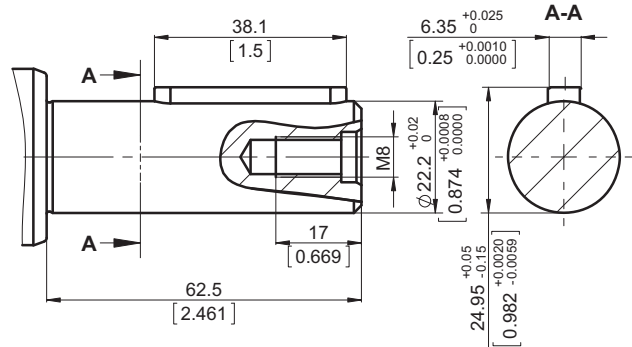

ML

$\varnothing 25$ [0.984] straight, M8 thread
Parallel key $A8 \times 7 \times 25$ DIN6885
Max. torque 250 Nm [2210 lb-in]

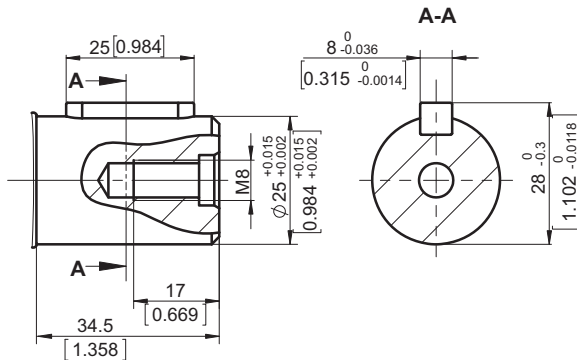

CM CMN

$\varnothing 25.4$ [1] straight, M8 thread
Parallel key $1/4 \times 1/4 \times 1$ " BS46
Max. torque 250 Nm [2210 lb-in]

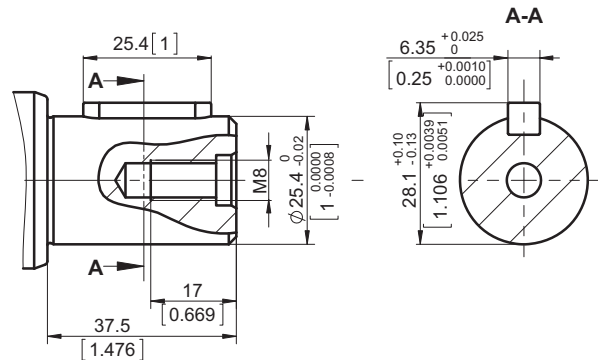

DO

$\varnothing 28.55$ [1.125] straight, 3/8-16 UNC thread
Parallel key $5/16 \times 5/16 \times 1/4$ "
Max. torque 280 Nm [2480 lb-in]

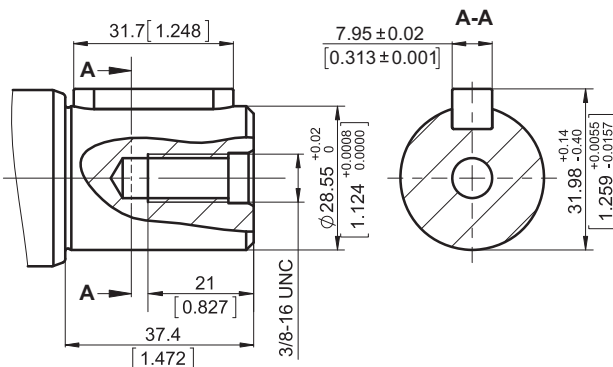

CQ

$\varnothing 30$ [1.181] straight, M8 thread
Parallel key $A8 \times 7 \times 32$ DIN6885
Max. torque 300 Nm [2655 lb-in]

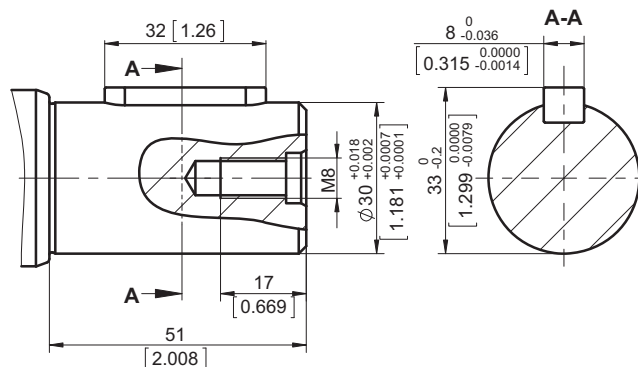

The required max. torque
must not be exceeded

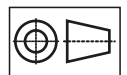

mm [in]

SHAFT TYPES AND DIMENSIONS

DR

ø31.75 [1.25] straight, 3/8-16 UNC thread
 Parallel key **5/16"x5/16"x1 ¼"**
 Max. torque 300 Nm [2655 lb-in]

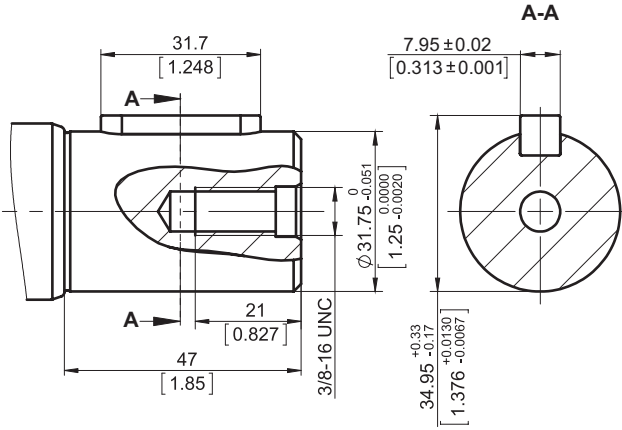

CS

ø32 [1.26] straight, M8 thread
 Parallel key **A10x8x45** DIN6885
 Max. torque 350 Nm [3100 lb-in]

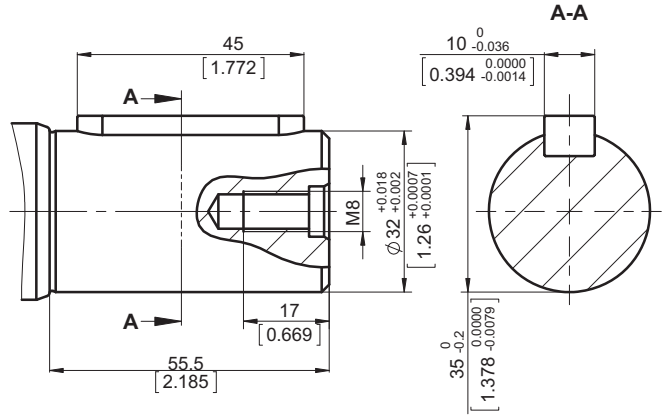

DU

ø38.1 [1½] straight, 3/8-16 UNC thread
 Parallel key **3/4"x3/4"x1½"** BS46
 Max. torque 1000 Nm [8850 lb-in]

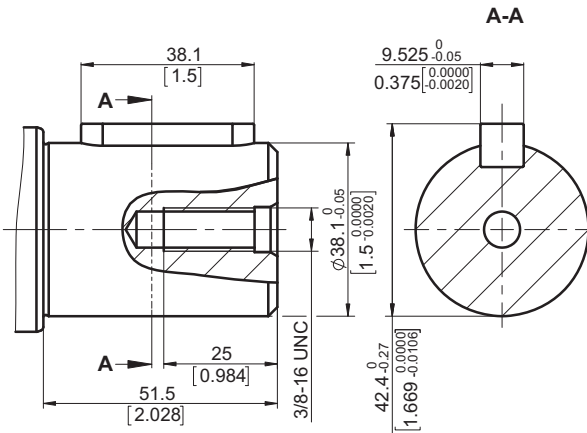

CV

ø40 [1.575] straight, M12 thread
 Parallel key **A12x8x63** DIN6885
 Max. torque 1100 Nm [9735 lb-in]

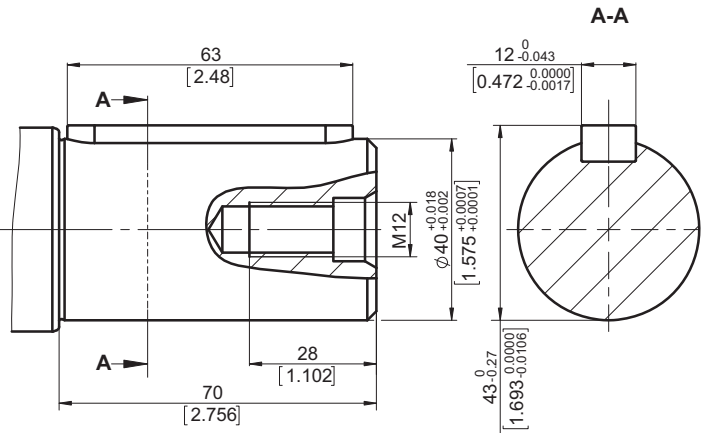

The required max. torque must not be exceeded

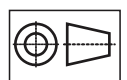

mm [in]

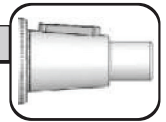

SHAFT TYPES AND DIMENSIONS

TD

ø22.22 [7/8] Tapered 1:8 [125:1000],
Parallel key 1/4"x1/4"x1", 5/8-18 UNF
Max. torque 220 Nm [1950 lb-in]

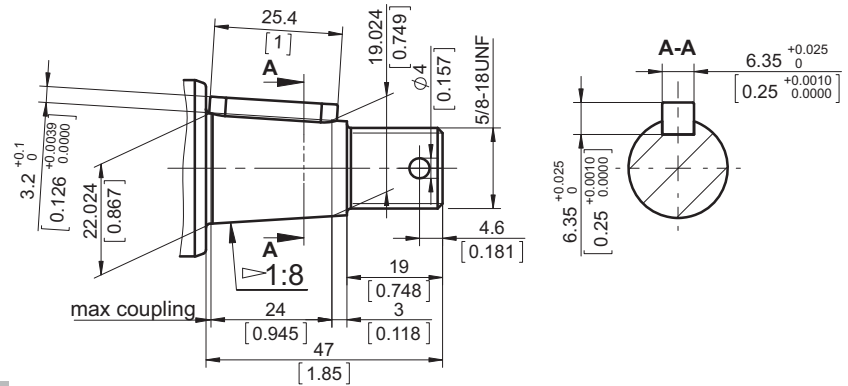

KH

ø25.4 [1] Tapered 1:8 [125:1000],
Parallel key 1/4"x1/4"x1", M16x1.5
Max. torque 300 Nm [2655 lb-in]

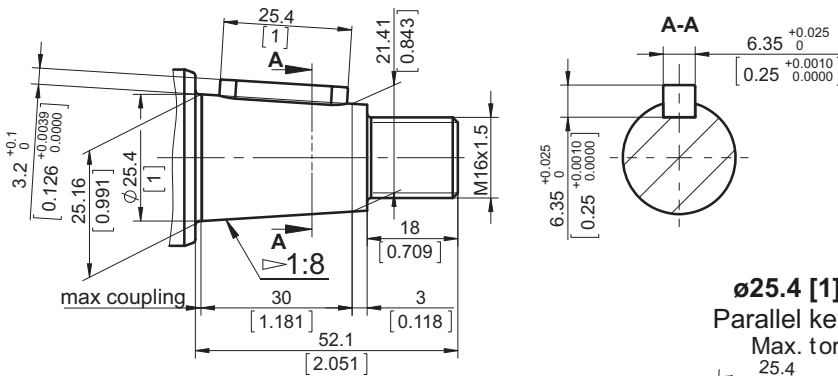

TH

ø25.4 [1] Tapered 1:8 [125:1000],
Parallel key 1/4"x1/4"x1", 3/4-16 UNF
Max. torque 300 Nm [2655 lb-in]

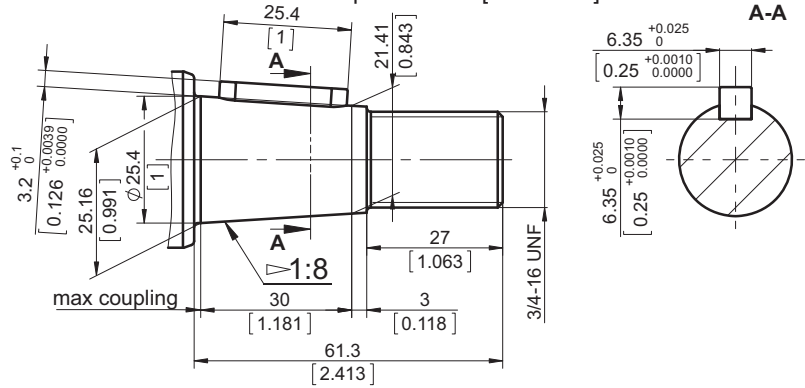

TN

ø31.75 [1 1/4] Tapered 1:8 [125:1000],
Parallel key 5/16"x5/16"x1 1/8", 1-12 UNF
Max. torque 500 Nm [4425 lb-in]

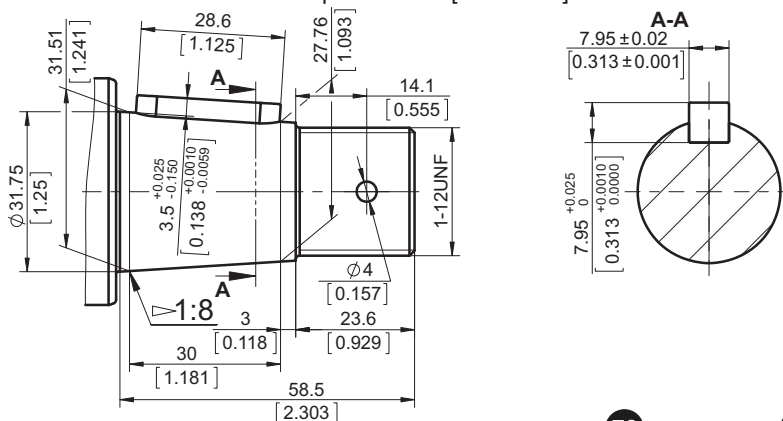

The required max. torque must not be exceeded

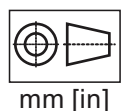

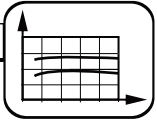

MOTOR FUNCTION DIAGRAMS

The below efficiencies are applied for all motor displacements.

VOLUMETRIC EFFICIENCIES

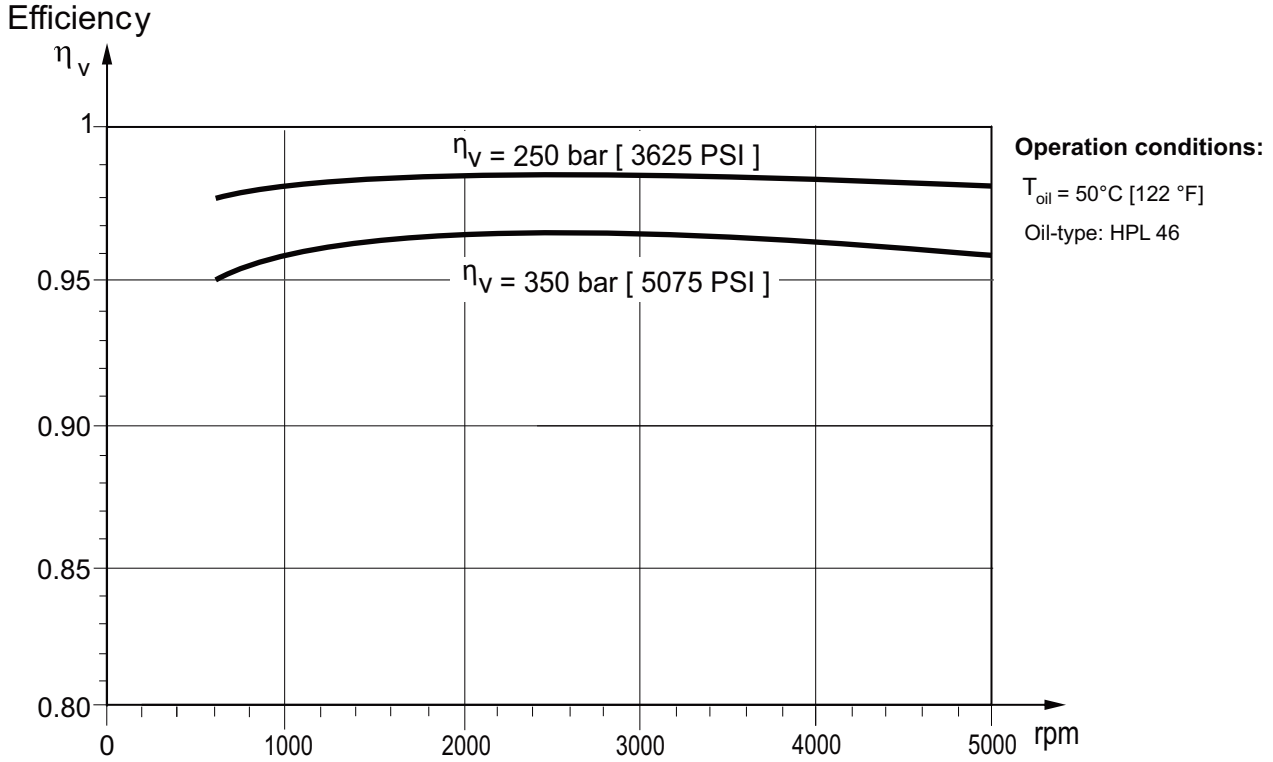

OVERALL EFFICIENCIES

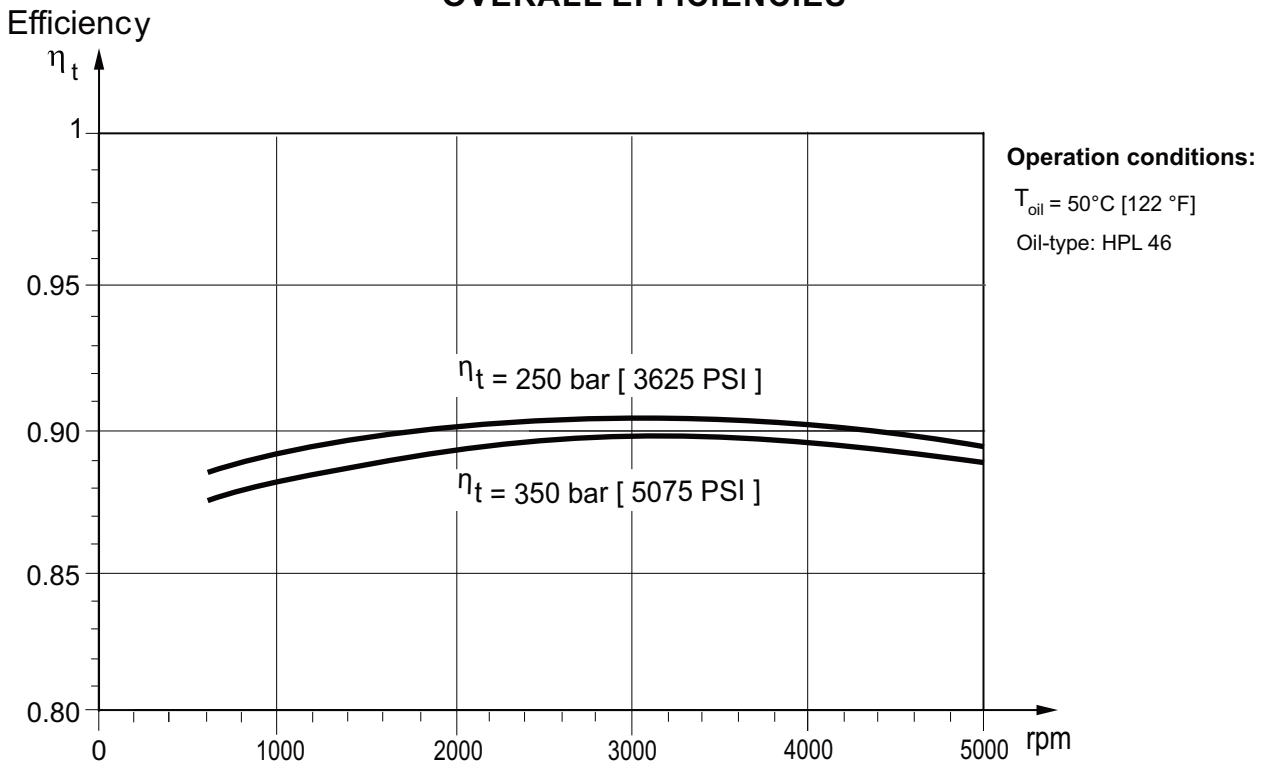

The motor size, pressure, torque, speed of rotation and flow rate required for a specific application can be calculated using the formulas on page [85](#)

Efficiencies for a particular motor may vary from the shown in the diagram depending on the operating conditions.

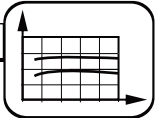

PUMP FUNCTION DIAGRAMS

The diagram is applied for all pump displacements.

Sound pressure level (noise) is measured in acoustic chamber according to DIN 45635 Part 1 and Part 26. These .

Noise level

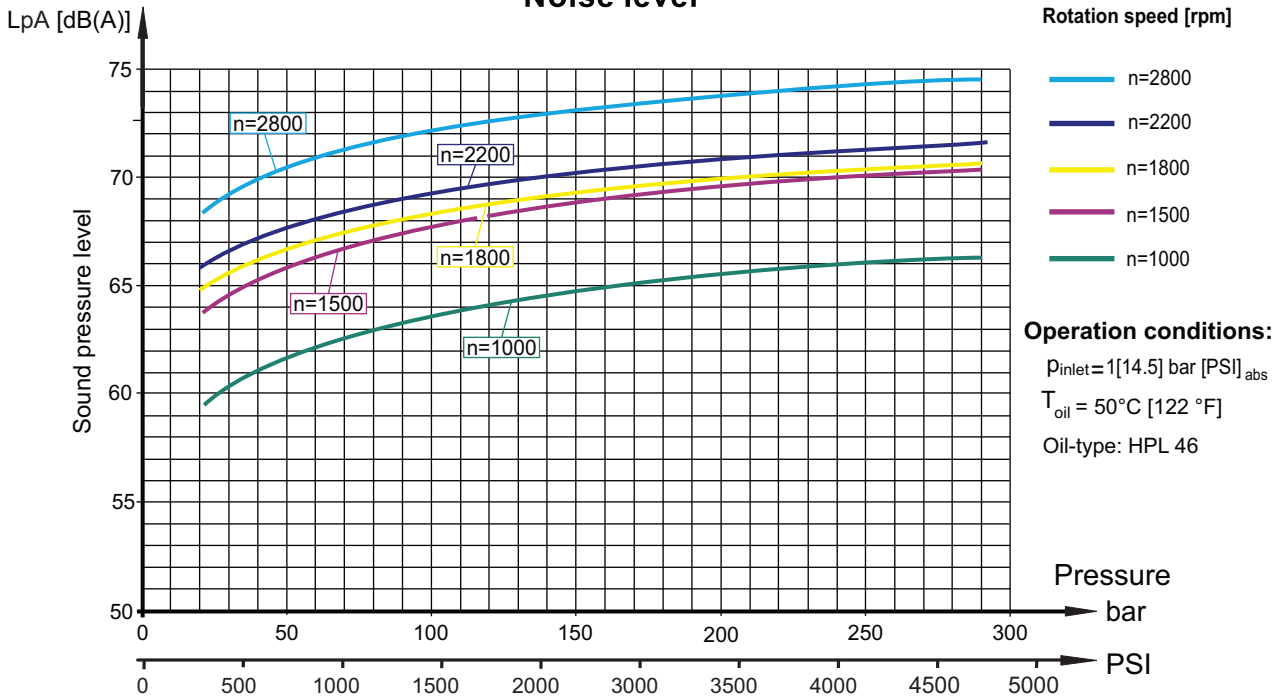

The sound pressure level for a particular pump may vary $\pm 2 \text{ dB(A)}$ compared to what is shown in the diagram.

Efficiency
 $\eta_t \eta_{mh} \eta_v$

The below efficiencies are applied for all displacements.

Efficiencies at 1000 rpm

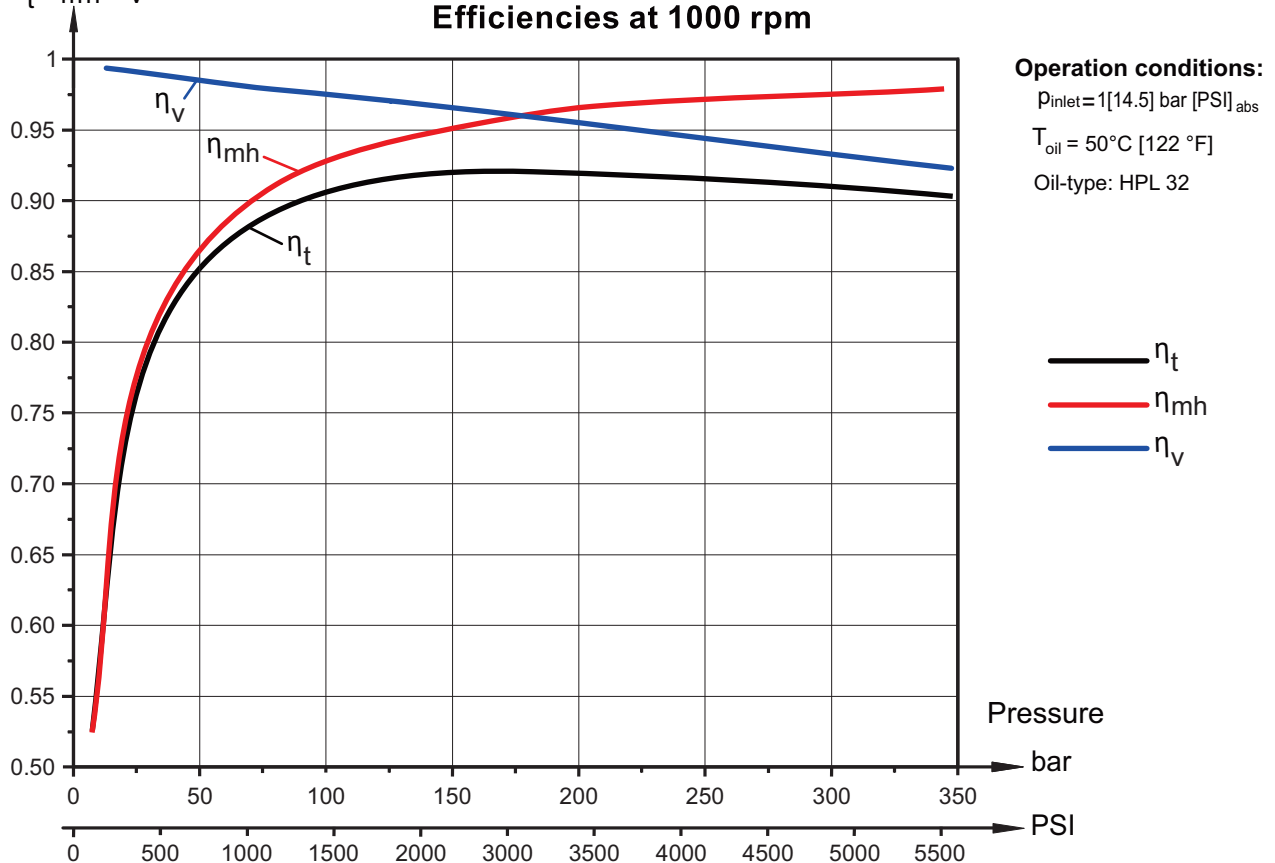

The pump size, pressure, torque, speed of rotation and flow rate required for a specific application can be calculated using the formulas on page [85](#)

Efficiencies for a particular pump may vary from the shown in the diagram depending on the operating conditions.

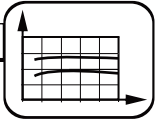

PUMP FUNCTION DIAGRAMS

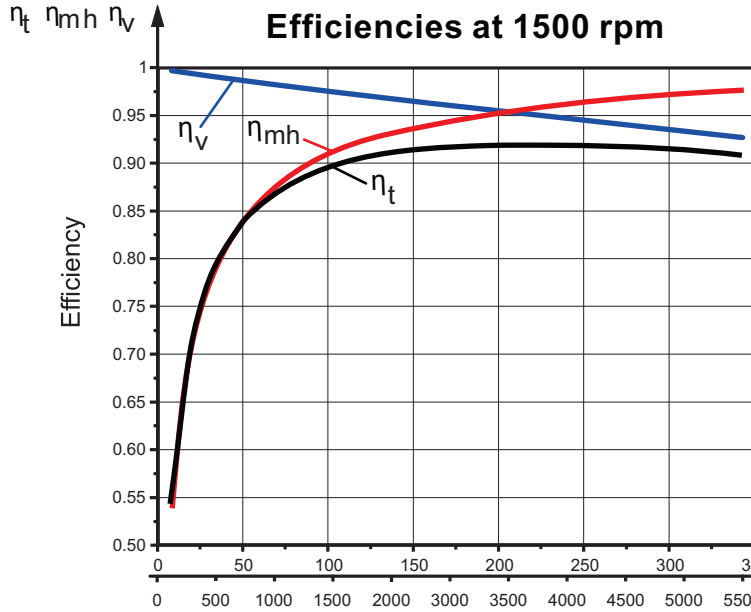

Operation conditions:

$P_{inlet} = 1 [14.5] \text{ bar [PSI]}_{abs}$

$T_{oil} = 50^\circ\text{C} [122^\circ\text{F}]$

Oil-type: HPL 32

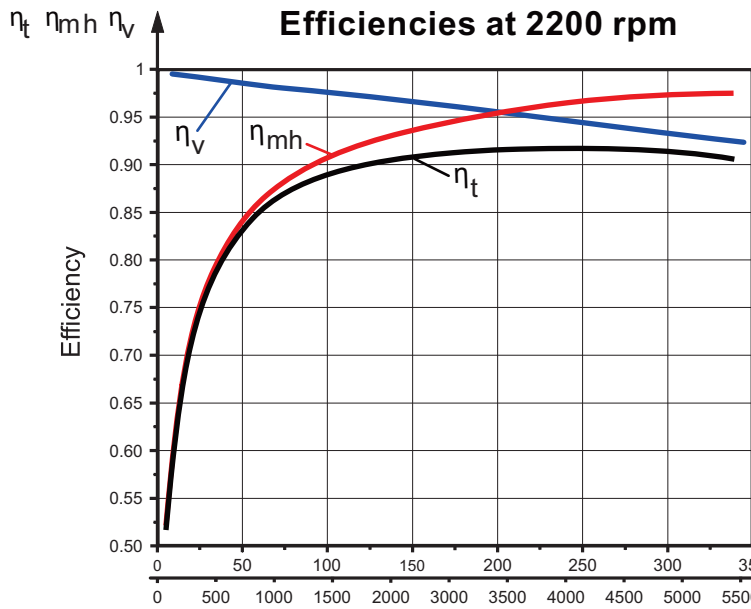
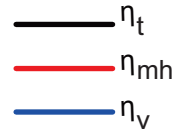

Operation conditions:

$P_{inlet} = 1 [14.5] \text{ bar [PSI]}_{abs}$

$T_{oil} = 50^\circ\text{C} [122^\circ\text{F}]$

Oil-type: HPL 32

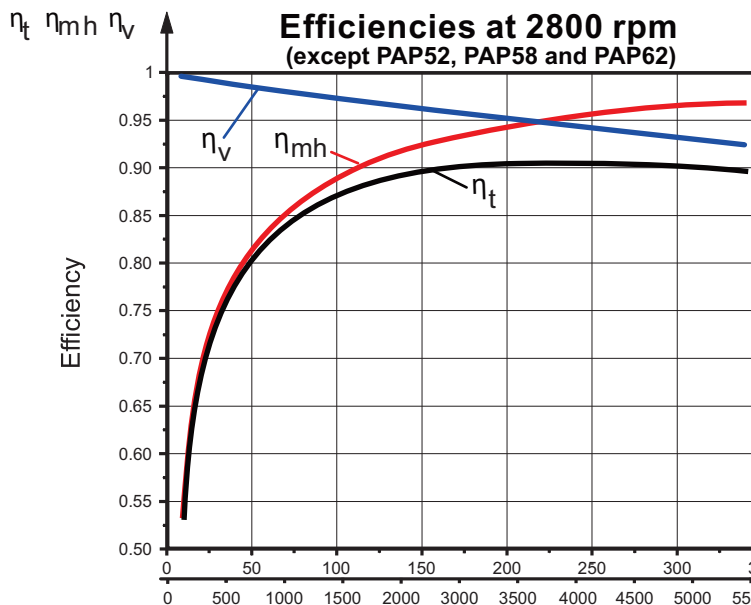
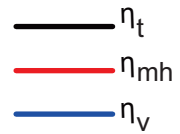

Operation conditions:

$P_{inlet} = 1 [14.5] \text{ bar [PSI]}_{abs}$

$T_{oil} = 50^\circ\text{C} [122^\circ\text{F}]$

Oil-type: HPL 32

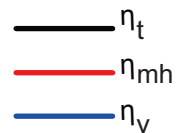

The pump size, pressure, torque, speed of rotation and flow rate required for a specific application can be calculated using the formulas on page [85](#)

Efficiencies for a particular pump may vary from the shown in the diagram depending on the operating conditions.



VALVE OPTIONS

The overall dimensions of the motor with integrated valves could vary compared to the standard motors.

Option PU
PURGE VALVE

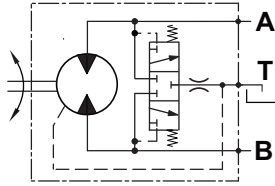

- Mainly used in open loop circuit;
- Used for cooling purpose or oil cleanliness requirements;
- Flow rate by **default** :

Motors	MAP28	MAP62	MAP100	MAPW62
default	5±2 l/min	6±2 l/min	7±2 l/min	6±2 l/min

- For other options, please see Flow Setting of ordering code, considering the following possible values:

Flow setting → flow rate

EXAMPLE

M A P B 5 0 S H 2 P U	purge valve flow rate 6±2 l/min
M A P B 5 0 S H 2 P U L 3 . 5	purge valve flow rate 3.5±1 l/min
M A P B 5 0 S H 2 P U L 5 . 5	purge valve flow rate 5.5±1 l/min

Option FLU
FLUSH VALVE

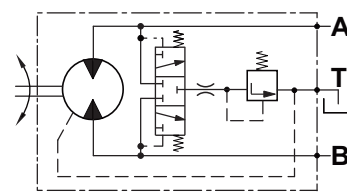

- Mainly used in close loop circuit;
- The valve is a combination between a purge valve and check valve;
- Flow rate by **default**

Motors	MAP28	MAP62	MAP100	MAPW62
default	5±2 l/min	6±2 l/min	7±2 l/min	6±2 l/min

and charge (opening) pressure 16 bar with 20 bar feed pressure for close loop circuit;

- For other options, please see Pressure Setting and Flow Setting of ordering code, considering the following possible values:

Pressure setting → pressure
Flow setting → flow rate

EXAMPLE

M A P B 5 0 S H 2 F L U	flow rate 6±2 l/min, charge pressure 16 bar
M A P B 5 0 S H 2 F L U 1 0 L 5 . 5	flow rate 5.5±1 l/min, charge pressure 10 bar
M A P B 5 0 S H 2 F L U L 3 . 5	flow rate 3.5±1 l/min, charge pressure 16 bar

Option DAR, SARA, SARB

Combined Anti-Cavitation and Relief Valve

- Anti-cavitation check valve is used for applications such as Fan drive control;
- Pressure relief valves prevent excessive pressures in the high pressure loop.

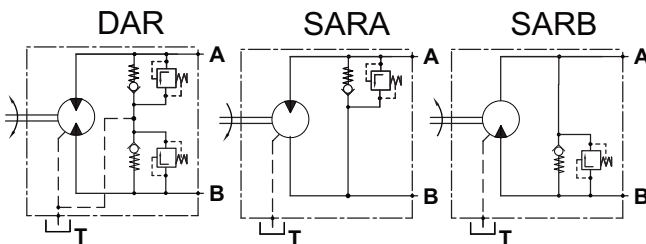

Please, consider the following possible values:

Pressure setting → pressure

EXAMPLE

M A P B 5 0 S H 2 D A R 3 5 0	Double Anti-Cavitation and Relief Valve, relief valve setting 350 bar
M A P B 5 0 S H 2 S A R A 2 5 0	Single Anti-Cavitation and Relief Valve, relief valve setting 250 bar The valve is placed on port A
M A P B 5 0 S H 2 S A R B 3 0 0	Single Anti-Cavitation and Relief Valve, relief valve setting 300 bar The valve is placed on port B

Option AR, HRA, HRB
Anti-Cavitation Valve

- Anti-cavitation check valve is used for applications such as Fan drive control.

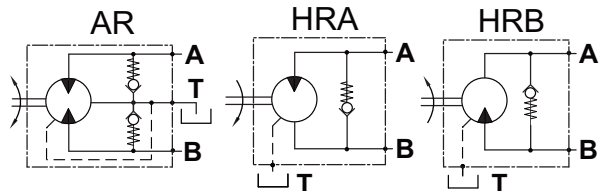

EXAMPLE

M A P B 5 0 S H 2 A R	Double Anti-Cavitation Valve
M A P B 5 0 S H 2 H R A	Single Anti-Cavitation Valve, the valve is placed on port A
M A P B 5 0 S H 2 H R B	Single Anti-Cavitation Valve, the valve is placed on port B



VALVE OPTIONS

The overall dimensions of the motor with integrated valves could vary compared to the standard motors.

Option DARP

Dual Anti-Cavitation, Relief and Purge Valve

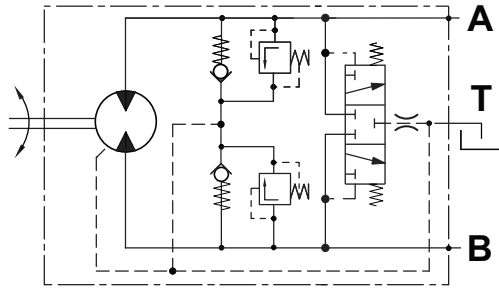

- Mainly used in open loop circuit;
- The valve is a combination between a dual anti-cavitation, relief and purge valve;
- Purge Valve is used for cooling purpose or cleanliness requirements;
- Anti-Cavitation Check Valve is used for applications such as Fan drive control;
- Pressure relief valves prevent excessive pressures in the high pressure loop;
- Please, consider the following possible values for pressure set of the relief valve:

Pressure setting → pressure

- Flow rate of purge valve by **default**

Motors	MAP28	MAP62	MAP100	MAPW62
default	5±2 l/min	6±2 l/min	7±2 l/min	6±2 l/min

The possible values are as follow:

Flow setting → flow rate

EXAMPLE

MAPB50SH2DARP350

Double Anti-Cavitation, Relief and Purge Valve, relief valve setting 350 bar, purge valve flow rate 6±2 l/min

MAPB50SH2DARP250L3.5

Double Anti-Cavitation, Relief and Purge Valve, relief valve setting is 250 bar, purge valve flow rate 3.5±1 l/min

MAPB50SH2DARP300L5.5

Double Anti-Cavitation, Relief and Purge Valve, relief valve setting 300 bar, purge valve flow rate 5.5±1 l/min

Option DARF

Dual Anti-Cavitation, Relief and Flush Valve

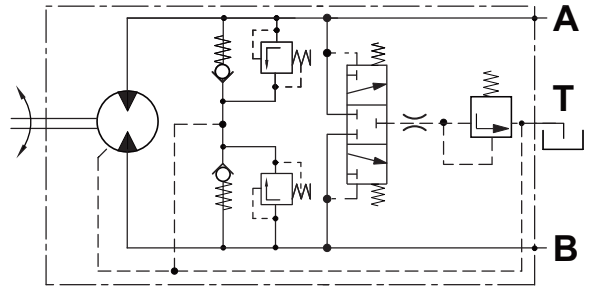

- Mainly used in close loop circuit;
- The valve is a combination between a dual anti-cavitation, relief and flush valve;
- Flush valve is used for cooling purpose or cleanliness requirements;
- Anti-Cavitation Check valve is used for applications such as Fan drive control;
- Pressure Relief Valves prevent excessive pressures in the high pressure loop;
- Please, consider the following possible values for pressure set of the relief valve:

Pressure setting → pressure

- Flow rate of flush valve by **default**

Motors	MAP28	MAP62	MAP100	MAPW62
default	5±2 l/min	6±2 l/min	7±2 l/min	6±2 l/min

and charge pressure 16 bar with 20 bar feed pressure for close loop circuit. The possible values are as follow:

Flow setting → flow rate

- Other values for charge pressure are possible. Please see Pressure Setting. Example: For charge pressure 10 bar the options are as follow:

Pressure setting

Relief valve opening pressure Flush valve opening pressure (charge pressure)

EXAMPLE

MAPB50SH2DARF350

Double Anti-Cavitation, Relief and Flush Valve, relief valve setting 350 bar flush valve charge pressure 16 bar, flush valve flow rate 6±2 l/min

MAPB50SH2DARF350-10

Double Anti-Cavitation, Relief and Flush Valve, relief valve setting 350 bar flush valve charge pressure 10 bar, flush valve flow rate is 6±2 l/min

MAPB50SH2DARF250L3.5

Double Anti-Cavitation, Relief and Flush Valve, relief valve setting 250 bar flush valve charge pressure 16 bar, flush valve flow rate is 3.5±1 l/min

MAPB50SH2DARF300-10L5.5

Double Anti-Cavitation, Relief and Flush Valve, relief valve setting 300 bar flush valve charge pressure 10 bar, flush valve flow rate 5.5±1 l/min

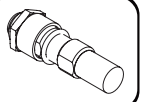

SPEED SENSORS

MOUNTING DIMENSIONS

MAP28 and PAP28

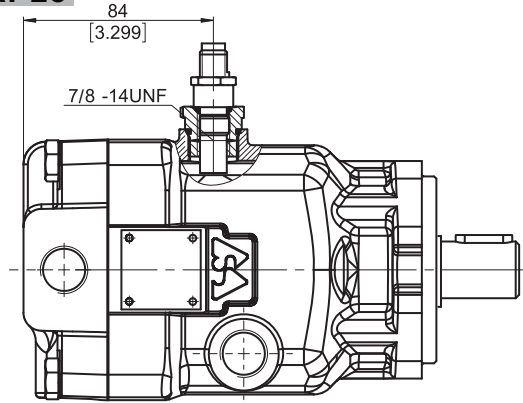
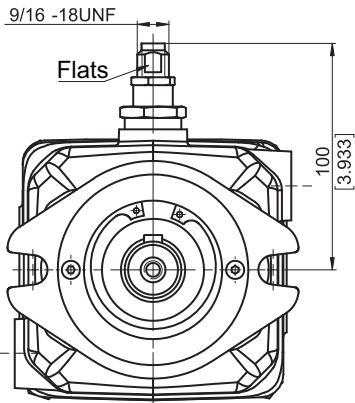

MAP62, MAPW62 and PAP62

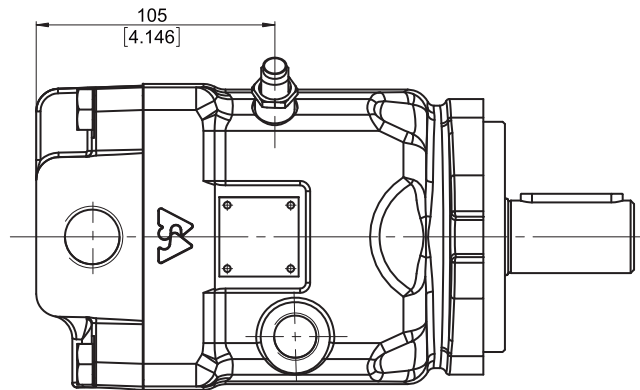
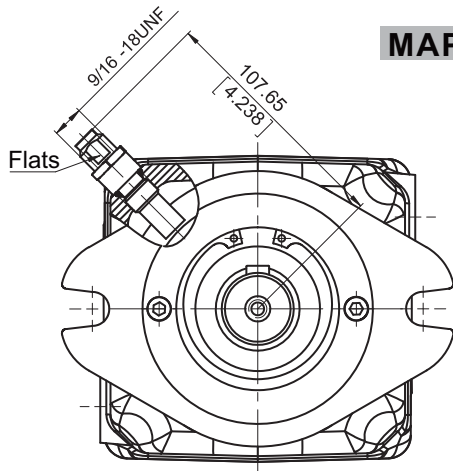

MAP100

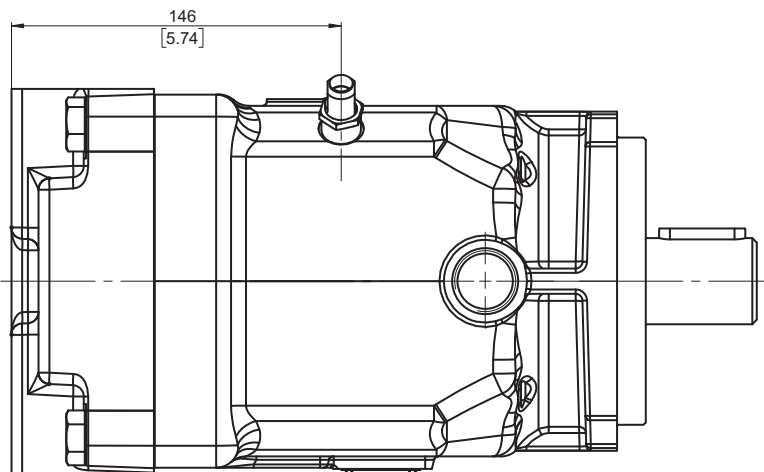
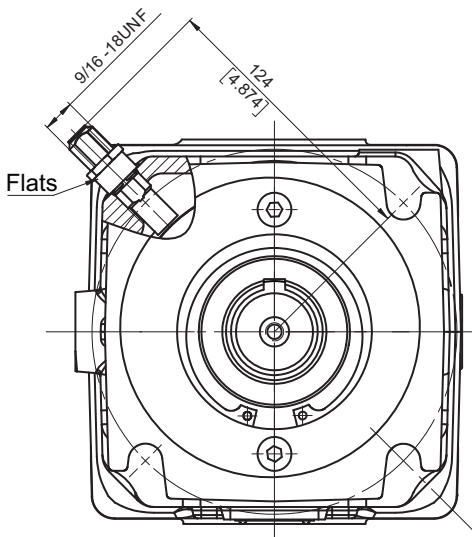

INSTALLATION



1. Remove the plug.
2. Screw in the (CW) sensor by hand until the bottom end gently touches the speed ring.
3. Unscrew (CCW) sensor 1/4 turn. Continue unscrewing until the flats are perpendicular to motor or pump shaft center line (tolerance 20° to 30° is acceptable). Do not unscrew the sensor more than 3/4 of a turn from the touching.
4. Using the 1/2 inch wrench to hold the sensor, tighten the lock nut to 10^{±5}[115] Nm [lb-in]. with an 1 1/16 inch hew wrench.

NOTE: The speed sensor is not fitted at the factory, but is supplied in plastic bag with the motor. For installation see enclosed instructions.

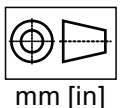

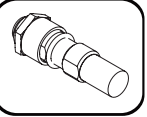

SPEED SENSORS

TECHNICAL DATA OF THE SPEED SENSOR

TECHNICAL DATA

Power supply 4.5 ... 30 VDC
 Power consumption < 15 mA without load
 Pin connector universal /PUSH-PULL/
 4P Delphi Connector DJ3042-2.5-21
 Speed, Direction
 Output measurements
 Output maximum current 100 mA
 Resident output voltage 1.5 V with 100 mA of the output
 0.5 V without load of the output
 Frequency range 0 ... 15 000 Hz
 Degree of protection IP 67
 Temperature -40 ... + 100 °C
 Humidity 0 ... 95% RH

OUTPUT PULSES

per revolution

Motor Type	MAP28	MAP62	MAPW62	MAP100
Output Pulses	42	50	50	65

Pump Type	PAP28	PAP62
Output Pulses	42	50

OUTPUT DIAGRAMS

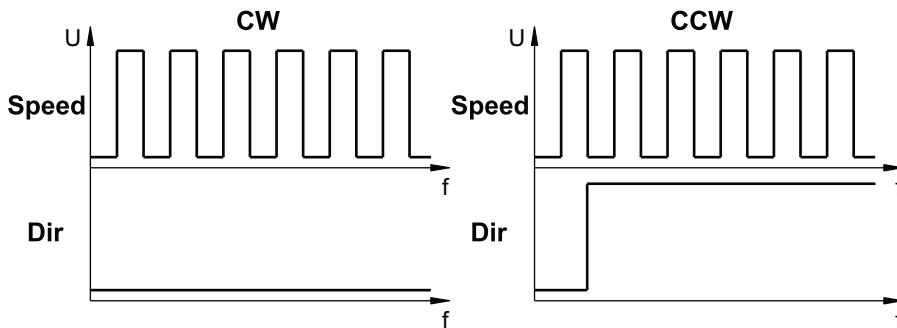

PIN CONNECTOR

4 pin Delphi Connector

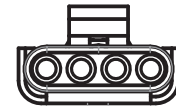

Pin	Connection	Cable Output
A	Power+	Red
B	Speed	White
C	Ground	Black
D	Direction	Green

WIRING DIAGRAMS

Sensor could be in use for both type of connections - PNP or NPN

PNP

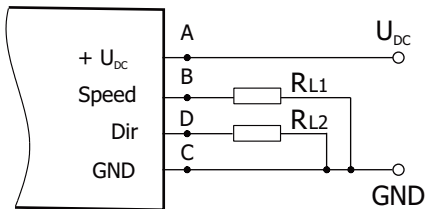

NPN

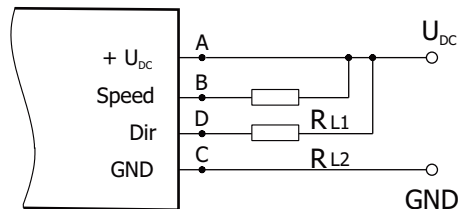

SENSOR OVERALL DIMENSIONS

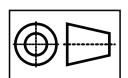
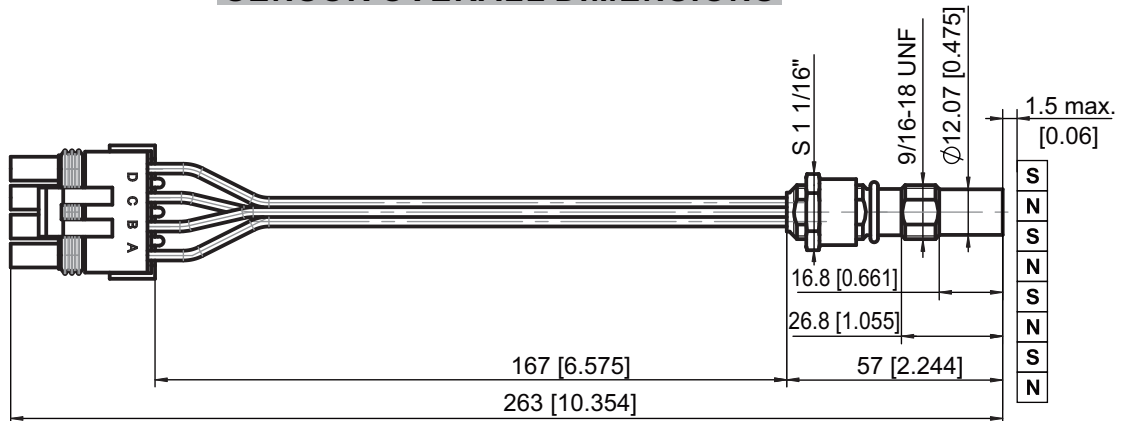

mm [in]



INSTALLATION

TYPE OF CONNECTION

Series connection
not recommended

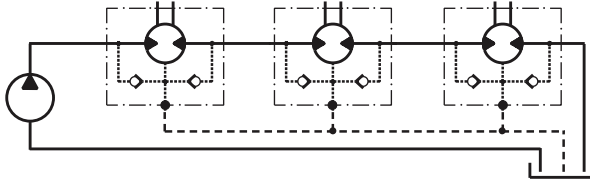

open drain line is always required

Parallel connection
recommended

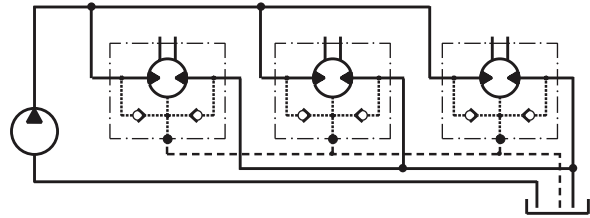

open drain line is always required

DIRECTION OF ROTATION

Standard Rotation
Viewed from shaft end
Port A Pressurized - CW
Port B Pressurized - CCW

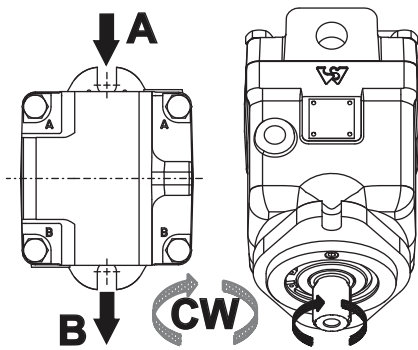

Reverse Rotation
Viewed from shaft end
Port A Pressurized - CCW
Port B Pressurized - CW

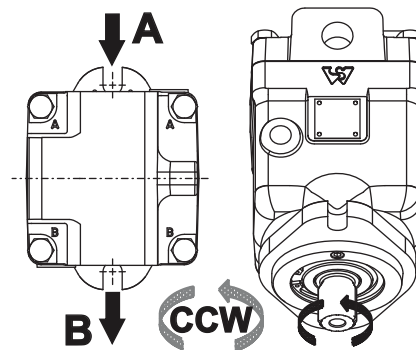

BEST POSITION FOR APPLYING RADIAL LOAD

Optimal position for applying radial load depending on the direction of rotation

Standard Rotation

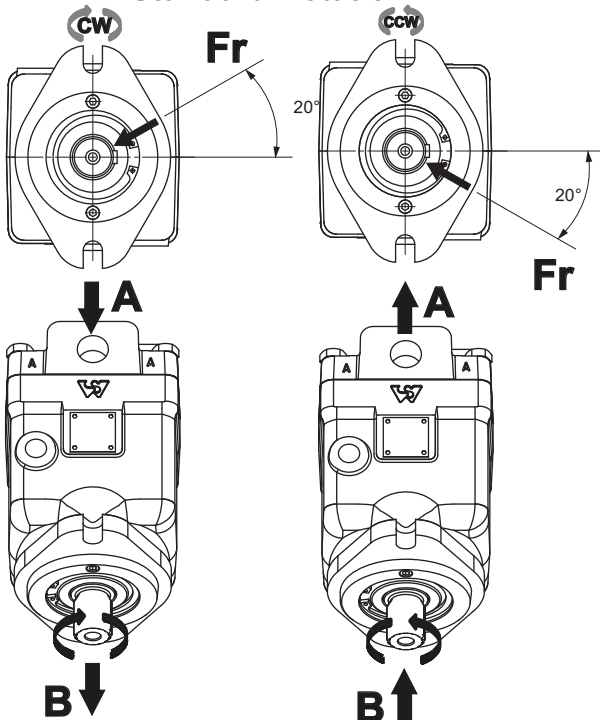

Reverse Rotation

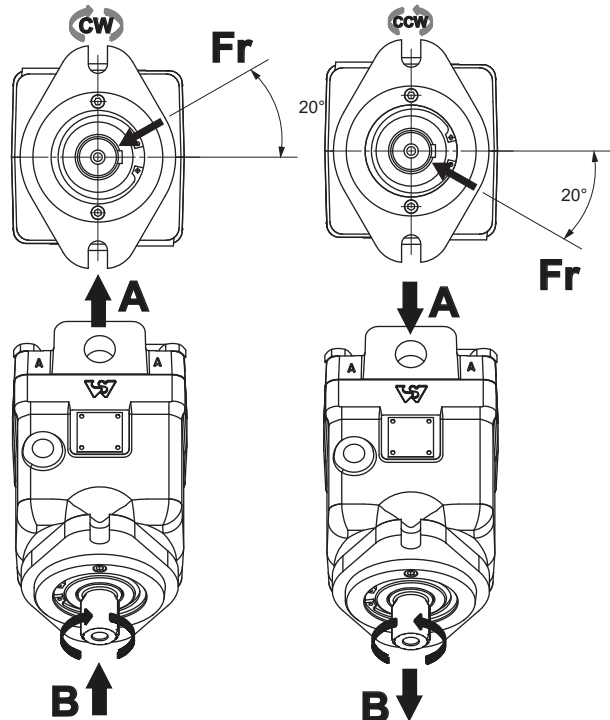



INSTALLATION

Recommended max. tightening torque X for metal plugs and orifice

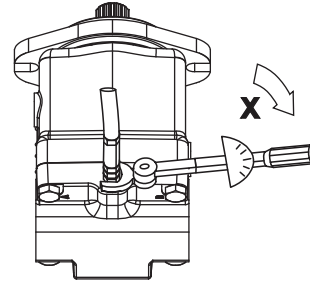
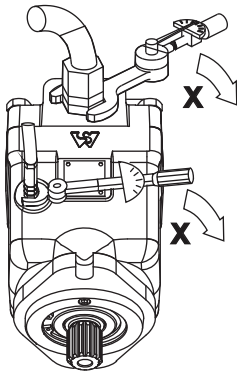

Screwed connection Anschlussart Raccord Tipo di collegamento Especie de unir Присоединительные резьбы	Max. Tightening Torque X, daNm [lb-in] Max. Anzugsmoment X, daNm [lb-in] Couple de serrage maxi X, daNm [lb-in] Momento di serraggio max. X, daNm [lb-in] Momento d'apretadura max. X, daNm [lb-in] Момент затяжки X, daNm [lb-in]			
	With copper washer Mit Kupferscheibe Avec rondelle en cuivre Con rondella di rame De arandela de cobre С медной шайбой	With aluminium washer Mit Aluminiumscheibe Avec rondelle en aluminium Con rondella di alluminio De arandela d'aluminio С алюминиевой шайбой	With cutting edge Mit Dichtkante Tranchant Con tagliente di guarnizione De borde compactar С крутым бортиком	With "O" ring Mit "O" Ring Avec joint torique Con "O"-anello De "O"-anillo С резиновым кольцом
M 8	1.6 [150]	1 [88.5]	2 [180]	
M 10	3.2 [300]	1 [88.5]	2 [180]	
M 12	3.5 [310]	3 [265]	4 [360]	
M14x1.5	4 [360]	3 [265]	4 [360]	3 [265]
M16x1.5	5 [450]	5 [450]	6 [550]	5 [450]
M18x1.5	6 [550]	5 [450]	6 [550]	5 [450]
M20x1.5	8 [710]	8 [700]	10 [885]	8 [700]
M22x1.5	10 [900]	8 [700]	10 [885]	8 [700]
M24x1.5	12 [1070]	10 [885]	10 [885]	10 [885]
M27x2	16 [1420]	13 [1150]	10 [885]	10 [885]
G 1/4	4 [360]	3 [265]	4 [360]	2 [180]
G 3/8	5 [450]	5 [450]	6 [550]	2 [180]
G 1/2	8 [710]	8 [700]	10 [885]	3 [265]
G 3/4	16 [1420]	13 [1150]	16 [1400]	5 [450]
G 1	20 [1800]	20 [1770]	25 [2200]	8 [700]
1/8 - 14(UNF)	2.5 [230]			0.7 [62]
3/8-24(16)UNF(UNC)	3 [270]			1.5 [130]
7/16-20(16)UNF	3.5 [310]			2 [180]
9/16-18 UNF	4 [360]			2 [180]
9/16-20 UNF	5 [450]			3.5 [310]
3/4 -16 UNF	6 [550]			6 [550]
7/8 -14(16)UNF	10 [900]			7 [620]
1 1/16 - 12 UN	16 [1420]			9 [800]
1 5/16 -12 UN	20 [1800]			16 [1400]
1/2 -14 NPTF				3 [265]
1/4 - 18 NPTF				3 [265]

Recommended max. tightening torque Y for screws and bolts

Motor Type	End Cover - Body		Axial Piston Group - Body		Axial Piston Group	
	Bolt	daNm [lb-in]	Screw	daNm [lb-in]	Screw	daNm [lb-in]
MAPA28	M10 - 12.9	7[620]	M4 - 12.9	0.4[40]	M5 - 12.9	0.6[60]
MAPB28	M10 - 12.9	7[620]	M5 - 12.9	0.6[60]	M5 - 12.9	0.6[60]
MAP62	M12 - 12.9	10[890]	M6 - 12.9	1.3[120]	M6 - 12.9	1.3[120]
MAPW62	M12 - 12.9	10[890]	M6 - 12.9	1.3[120]	M6 - 12.9	1.3[120]
MAP100	M14 - 12.9	13[1160]	M8 - 12.9	3.5[310]	M6 - 12.9	1.3[120]
PAPA28	M10 - 12.9	7[620]	M4 - 12.9	0.4[40]	M5 - 12.9	0.6[60]
PAP62	M12 - 12.9	10[890]	M6 - 12.9	1.3[120]	M6 - 12.9	1.3[120]

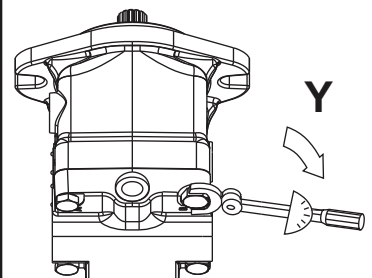
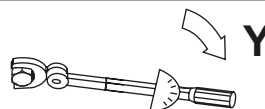



INSTALLATION

At start-up and during operation the motor(pump) housing has to be filled up with hydraulic fluid. Start-up has to be carried out at low or moderate speed and without load (for example 1000 rpm and pressure 50[725] bar [PSI]) till the motor(pump) and the hydraulic scheme are filled up with oil. Generally the start-up needs 10-15 minutes to finish. The leakage oil in the housing has to be discharged to the tank through the highest positioned drain port T. The max. pressure in the drain line is 5 [70] bar [PSI].

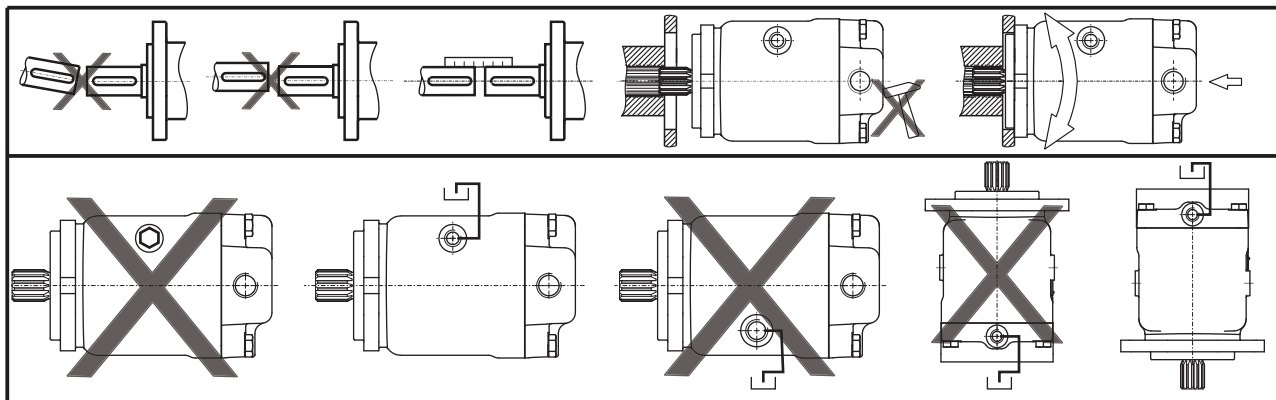

Installation below the tank level (recommended)

- Fill up the axial piston motor(pump) before the start-up through the highest positioned drain port T.
- Operate the motor(pump) at low speed till the motor system is completely filled up.
- The minimum immersion depth of the drain line in the tank is 200 mm [8 in] relative to the minimum oil level in the tank.

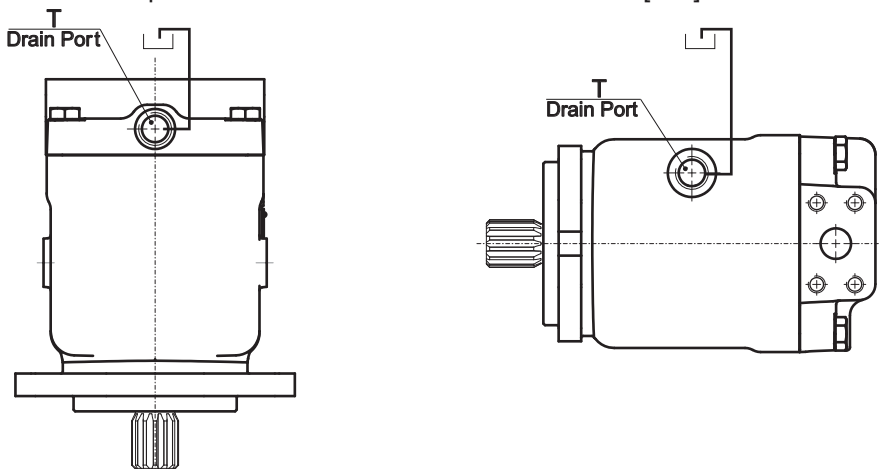

Installation on top of the tank level

- Fill up the axial piston motor(pump) before the start-up through the highest positioned drain port T.
- Operate the motor(pump) at low speed till the motor system is completely filled up.
- The minimum immersion depth of the drain line in the tank is 200 mm [8 in] relative to the minimum oil level in the tank.

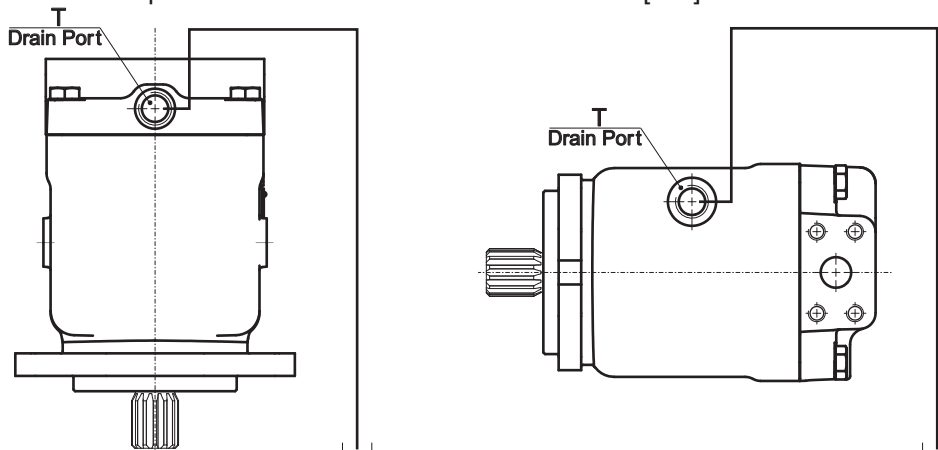



FLUID VISCOSITY LIMITS

In order to obtain optimum efficiency and service life, we recommend to select the operating viscosity (at operating temperature) within the range shown on diagram below.

Kinematic viscosity

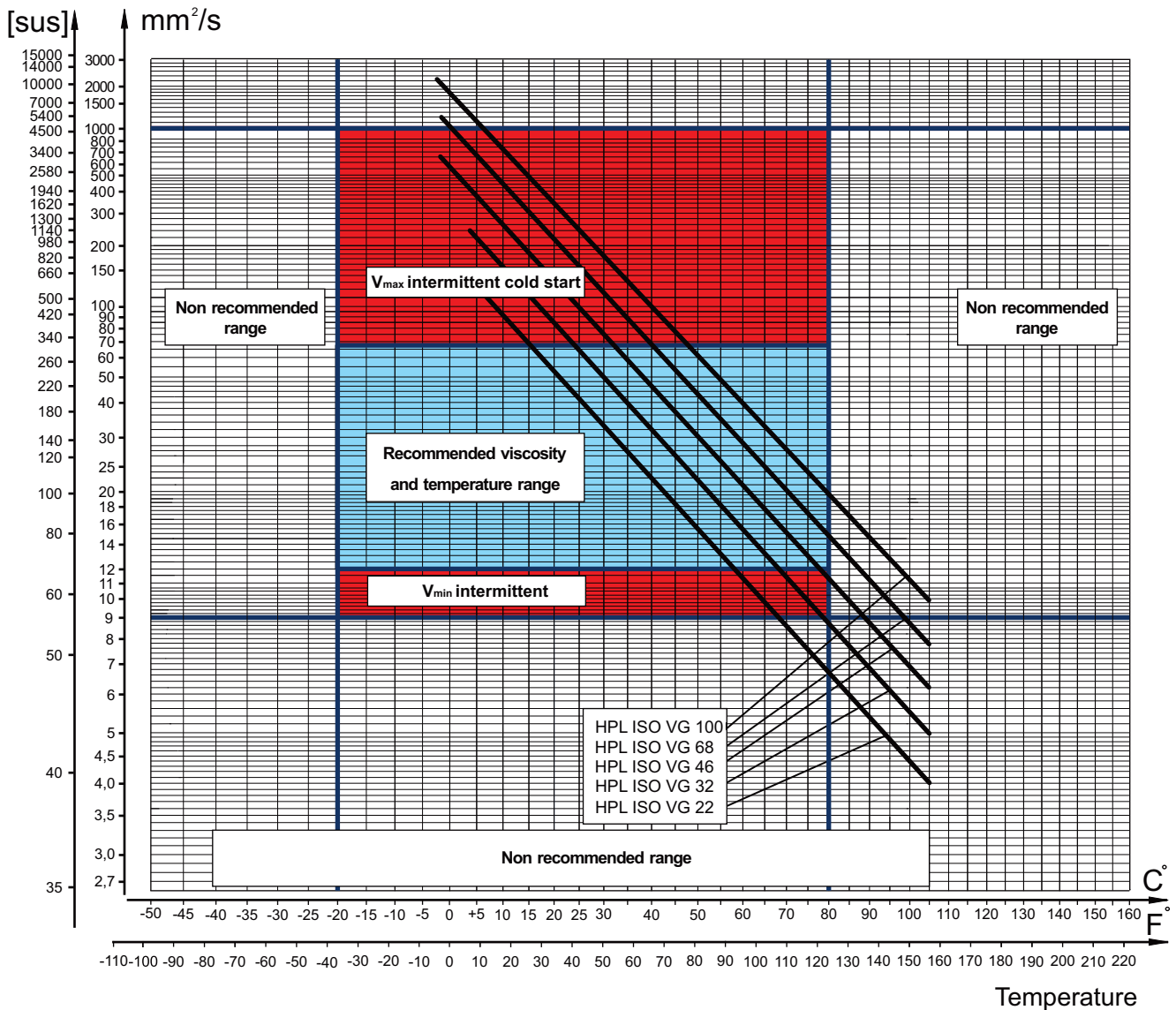

The above - shown viscosity characteristics are for reference only. Please, check the actual viscosity with the manufacturer of the fluid.



BASIC FORMULAS

The motor(pump) size, pressure and flow required for a specific application can be calculated using the formulas below.

Metric System		Inch System	
Efficiency	$\eta_t = \eta_{mh} \cdot \eta_v$ $\eta_{mh} = \frac{\eta_t}{\eta_v}$ $\eta_v = \frac{\eta_t}{\eta_{mh}}$	Efficiency	$\eta_t = \eta_{mh} \cdot \eta_v$ $\eta_{mh} = \frac{\eta_t}{\eta_v}$ $\eta_v = \frac{\eta_t}{\eta_{mh}}$
Input flow (for Motor)	$Q = \frac{Vg \cdot n}{1000 \cdot \eta_v}$ [l/min]	Input flow (for Motor)	$Q = \frac{Vg \cdot n}{231 \cdot \eta_v}$ [GPM]
Output torque (for Motor)	$M = \frac{Vg \cdot \Delta p \cdot \eta_{mh}}{62,8}$ or $M = \Delta p \cdot T_{con.}$ [Nm]	Output torque (for Motor)	$M = \frac{Vg \cdot \Delta p \cdot \eta_{mh}}{2 \cdot \pi}$ or $M = \Delta p \cdot T_{con.}$ [lb-in]
Output power (for Motor)	$P = \frac{M \cdot n}{9550} = \frac{Q \cdot \Delta p \cdot \eta_t}{600}$ [kW]	Output power (for Motor)	$P = \frac{Vg \cdot n \cdot \Delta p \cdot \eta_t}{396000}$ [hp]
Speed (for Motor)	$n = \frac{Q \cdot 1000 \cdot \eta_v}{Vg}$ or $n = Q \cdot N_{con.}$ [min ⁻¹]	Speed (for Motor)	$n = \frac{Q \cdot 231 \cdot \eta_v}{Vg}$ or $n = Q \cdot N_{con.}$ [min ⁻¹]
Output flow (for pump)	$Q = \frac{Vg \cdot n \cdot \eta_v}{1000}$ [l/min]	Output flow (for pump)	$Q = \frac{Vg \cdot n \cdot \eta_v}{231}$ [GPM]
Driving torque (for pump)	$M = \frac{Vg \cdot \Delta p}{62,8 \cdot \eta_{mh}}$ [Nm]	Driving torque (for pump)	$M = \frac{Vg \cdot \Delta p}{2 \cdot \pi \cdot \eta_{mh}}$ [lb-in]
Input power (for pump)	$P = \frac{M \cdot n}{9550} = \frac{Q \cdot \Delta p}{600 \cdot \eta_t}$ [kW]	Input power (for pump)	$P = \frac{Vg \cdot n \cdot \Delta p}{396000 \cdot \eta_t}$ [hp]
Vg	Displacement per rev. [cm ³]	Vg	Displacement per rev. [in ³]
Δp	p _{HP} - p _{LP} [bar]	Δp	p _{HP} - p _{LP} [PSI]
p_{HP}	High pressure [bar]	p_{HP}	High pressure [PSI]
p_{LP}	Low pressure [bar]	p_{LP}	Low pressure [PSI]
n	Rotation speed [RPM]	n	Rotation speed [RPM]
Q	Oil flow [l/min]	Q	Oil flow [GPM]
T_{con.}	Toque constant [Nm/bar]	T_{con.}	Toque constant [lb-in/PSI]
N_{con.}	Speed constant [RPM/(l/min)]	N_{con.}	Speed constant [RPM/GPM]
η_v	Volumetric efficiency	η_v	Volumetric efficiency
η_{mh}	Mechanical-hydraulic efficiency	η_{mh}	Mechanical-hydraulic efficiency
η_t	Overall efficiency	η_t	Overall efficiency

Depending on the results of the load calculations, the most appropriate type of motor from the catalogue is selected.

Table 1

Rolling resistance coefficient In case of rubber tire rolling on different surfaces			
Surface	ρ	Surface	ρ
Concrete- faultless	0.010	Macadam- bad	0.037
Concrete- good	0.015	Snow- 5 cm	0.025
Concrete- bad	0.020	Snow- 10 cm	0.037
Asphalt- faultless	0.012	Polluted covering- smooth	0.025
Asphalt- good	0.017	Polluted covering- sandy	0.040
Asphalt- bad	0.022	Mud	0.037÷0.150
Macadam- faultless	0.015	Sand- Gravel	0.060÷0.150
Macadam- good	0.022	Sand- loose	0.160÷0.300

APPLICATION FORMULAS

1. Motor speed: n, RPM

$$n = \frac{2,65 \cdot v_{km} \cdot i}{R_m} \quad n = \frac{168 \cdot v_{mi} \cdot i}{R_n}$$

v_{km} - vehicle speed [km/h]

v_{mi} - vehicle speed [mil/h]

R_m - wheel rolling radius [m]

R_n - wheel rolling radius [in]

i - gear ratio between motor and wheels.

If no gearbox, use $i=1$.

2. Rolling resistance: RR, daN [lbs]

The resistance force resulted in wheels contact with different surfaces:

$$RR = G \cdot \rho$$

G - total weight loaded on vehicle, daN [lbs];

ρ - rolling resistance coefficient (Table 1).

3. Grade resistance: GR, daN [lbs]

$$GR = G \cdot (\sin\alpha + \rho \cdot \cos\alpha)$$

α - gradient negotiation angle (Table 2)

Table 2

Grade %	α Degrees	Grade %	α Degrees
1%	0° 35'	12%	6° 5'
2%	1° 9'	15%	8° 31'
5%	2° 51'	20%	11° 19'
6%	3° 26'	25%	14° 3'
8%	4° 35'	32%	18°
10%	5° 43'	60%	31°

Table 3

Surface	Frictional factor f
Steel on steel	0.15 ÷ 0.20
Rubber tire on polluted surface	0.5 ÷ 0.7
Rubber tire on asphalt	0.8 ÷ 1.0
Rubber tire on concrete	0.8 ÷ 1.0
Rubber tire on grass	0.4

4. Acceleration force: FA, daN [lbs]

Force FA necessary for acceleration from 0 to maximum speed v and time t can be calculated with a formula:

$$FA = \frac{v_{km} \cdot G}{3,6 \cdot t \cdot 10} \text{ [daN]} \quad FA = \frac{v_{mi} \cdot G}{2,2 \cdot t} \text{ [lbs]}$$

FA - acceleration force, daN [lbs]

t - time, [s]

5. Tractive effort: DP, daN [lbs]

Tractive effort DP is the additional force of trailer. This value will be established as follows:

-acc. to constructor's assessment;

-as calculating forces in items 2, 3 and 4 of trailer. The calculated sum corresponds to the tractive effort requested.

6. Total tractive effort: TE, daN [lbs]

Total tractive effort TE is total effort necessary for vehicle motion; that the sum of forces calculated in items from 2 to 5 and increased with 10 % because of air resistance.

$$TE = 1,1 \cdot (RR + GR + FA + DP)$$

RR - force required to overcome the rolling resistance;

GR - force required to slope upwards;

FA - force required to accelerate (acceleration force);

DP - additional tractive effort (trailer).

7. Motor Torque moment: M, daNm [in-lb]

Necessary torque moment for every hydraulic motor:

$$M = \frac{TE \cdot R_m [R_n]}{N \cdot i \cdot \eta_M}$$

N - motor numbers;

η_M - mechanical gear efficiency (if it is available).

8. Cohesion between tire and road covering: M_w , daNm [in-lb]

$$M_w = \frac{G_w \cdot f \cdot R_m [R_n]}{i \cdot \eta_M}$$

To avoid wheel slipping, the following condition should be observed $M_w > M$

f - frictional factor;

G_w - total weight over the wheels, daN [lbs].

9. Radial motor loading: P_{rad} , daN [lbs]

When the motor is used for motion with a ring or gear mounted directly on the motor shaft, the total radial load of the motor shaft P_{rad} is the sum of the motion force and the weight force acting on the ring .

G_w - Weight held by wheel;

P_{rad} - Total radial loading of motor shaft;

M/R - Motion force.

$$P_{rad} = \sqrt{G_w^2 + \left(\frac{M}{R}\right)^2}$$

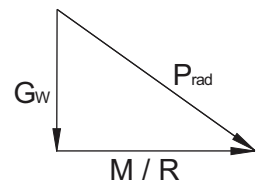

Depending on the results of the load calculations, the most appropriate type of motor from the catalogue is selected.

WARRANTY

M+S Hydraulic warrants, that its products, supplied directly to original equipment manufacturer, authorized distributor or other customer, will be free of defects in material or workmanship at the time of shipment from M+S Hydraulic and will conform to the products technical documentation (drawings and specifications) under sale agreement with Buyer.

This warranty will apply only to defects appearing within applicable Warranty period, mentioned below. If Buyer notifies M+S Hydraulic within the Warranty period about any such defects, M+S, at its sole option will replace or repair the defective products or their parts found by M+S Hydraulic to be defective in material or workmanship.

THE FOREGOING LIMITED WARRANTY IS AVAILABLE ONLY IF "M+S HYDRAULIC" IS PROMPTLY NOTIFIED IN WRITTEN OF THE ALLEGED DEFECT AND DOES NOT COVER FAILURE TO FUNCTION CAUSED BY DAMAGE TO THE PRODUCT, IMPROPER INSTALLATION, UNREASONABLE USE OR ABUSE OF THE PRODUCT, FAILURE TO PROVIDE OR USE OF IMPROPER MAINTENANCE OR USUAL, DEGRADATION OF THE PRODUCT DUE TO PHYSICAL ENVIRONMENTS OF AN USUAL NATURE. THE FOREGOING REMEDIES ARE THE SOLE AND EXCLUSIVE REMEDIES AVAILABLE TO CUSTOMER. To facilitate the inspection, M+S Hydraulic may require return of the product/part, which Buyer claims to be defective.

M+S Hydraulic shall not be liable for labor costs or any other expenses incurred during the disassembling or reinstalling of the product/part.

In case the claimed products are returned to M+S Hydraulic in bad condition: dirty, disassembled, with damaged or missing parts during transportation, the warranty will be considered as not applicable and the products will not be liable to repair.

Warranty periods

New products: The Warranty period is limited to 24 consecutive months (2 years) from the date of production of the product.

Repaired products: If the product is repaired in M+S Hydraulic during its warranty period, the warranty period of the repaired item shall continue for the balance of original Warranty period or for a period equal to 50% of the original new product Warranty period, whichever is later.

Spare parts: The Warranty period for Spare parts is 12 consecutive months (1 year) from the dispatch date of such parts from M+S Hydraulic.

LIMITATION OF LIABILITY M+S Hydraulic's liability for claim of any kind, for loss or damage arising out of, connected with or resulting from an order, or from the performance or branch thereof, or from the design, manufacture, sale delivery, operation or use of any of its products shall be limited to, at M+S 's sole option, replacement, repair of any defective product or the issuance of a credit to Customer against any future purchases. Cash refunds will not be made under any circumstances and Customer will not be entitled to recover any damages of any kind against M+S Hydraulic, including but not limited to incidental or consequential damages, whether direct or indirect, known or unknown, foreseen or unforeseen.

HES HYDRAULIC ELEMENTS AND SYSTEMS OVERVIEW



Hydraulic Elements and Systems PLC is a public stock company located in the town of Yambol, South-East Bulgaria. The factory has a long history and traditions in the design and manufacture of hydraulic cylinders. The product range includes Piston cylinders, Telescopic cylinders, Plunger cylinders and Rack cylinders.

M+S HYDRAULIC OVERVIEW

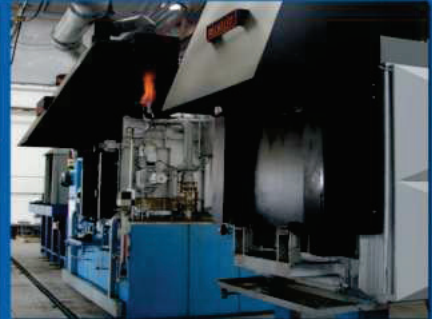

M+S Hydraulic is a leading manufacturer of Hydraulic Motors, Hydrostatic Steering Units and accessories, Hydraulic brakes Motor-brakes and Valve Blocks in Europe and all over the world.

The main advantage of our company is that we offer hydraulic solutions to the specific needs of the customers meeting their technical requirements thanks to the various product's options. M+S Hydraulic commodities are guaranteed with after-sales services, technical support and warranty period of 24 months.

M+S Hydraulic has an enlarging world-wide distributors' network. The company has Agency contracts and Consignment agreements with more than 35 companies in the world. We have the know-how to develop solutions for productivity and efficiency on every continent.

DEVOTED TO THE QUALITY

