

SECTION A-A

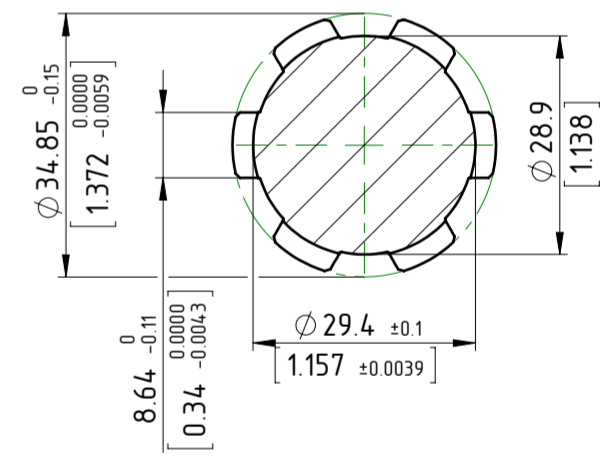

Hydraulic scheme

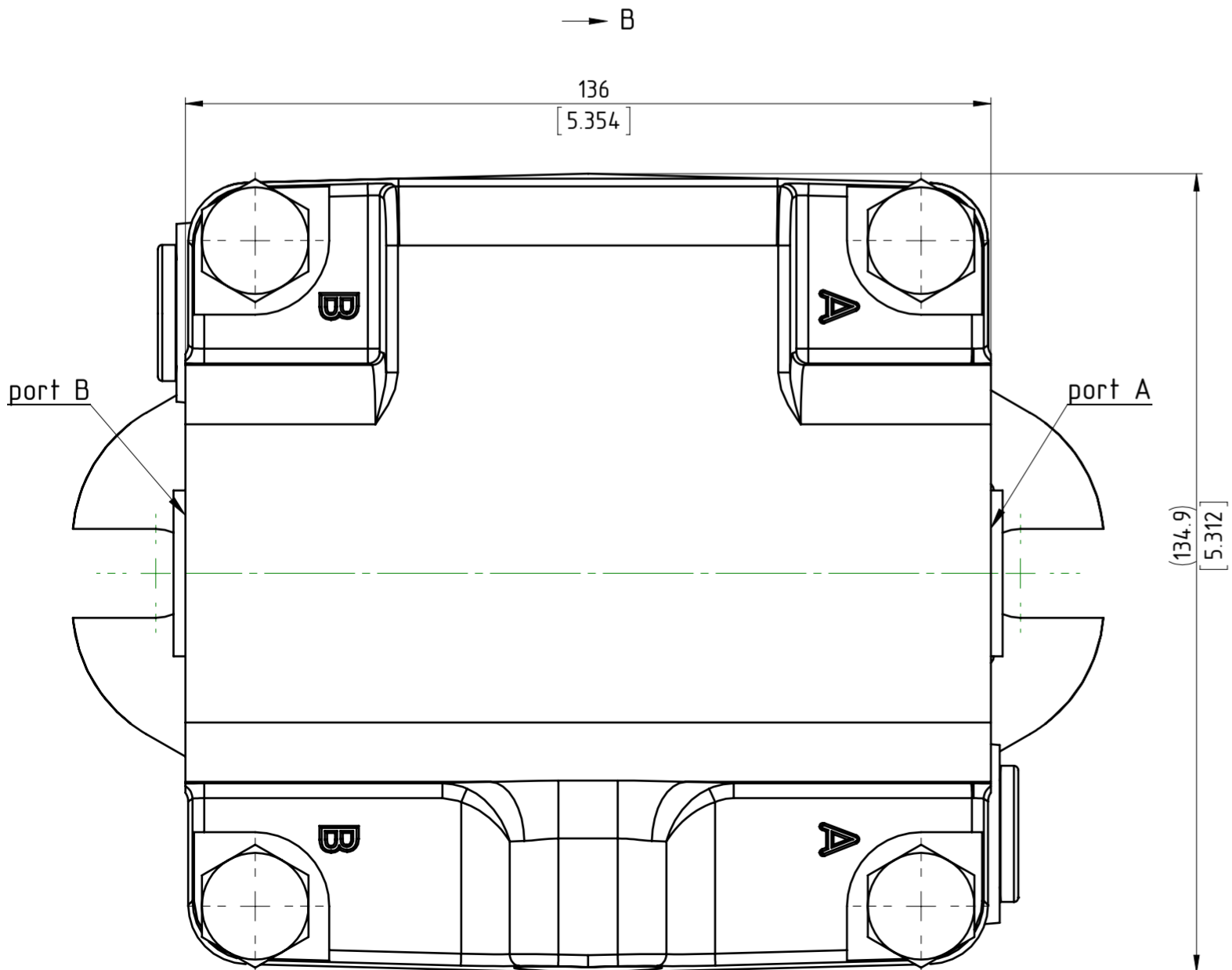
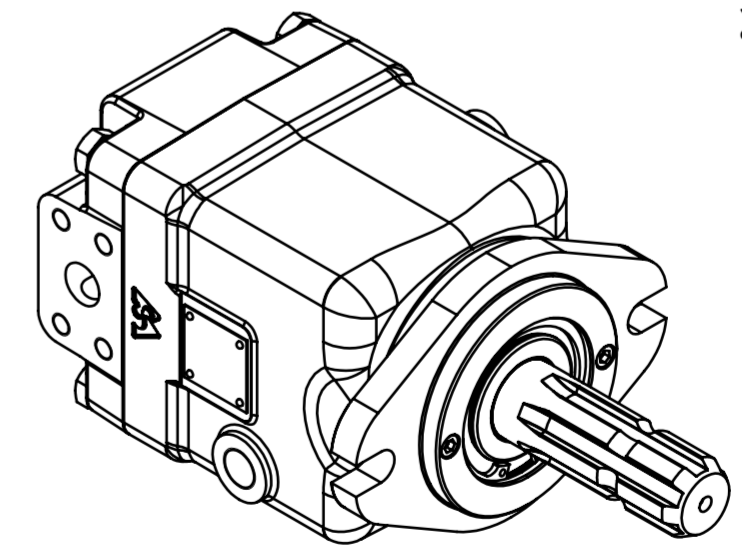
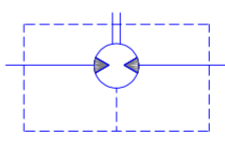

				Scale	Weight	material	
				1:1	18.21		
				Info			
				Sheet	1/1	PAPB40RSD axial piston heavy duty motor identification number id type II 1113000xx identification number id type I	
				Stage	NTR		
				Value			
Rev.	Nº of doc.	Signature	Data	3D file MAP46 01U 2D file offer MAPB50SL			
Design	Y. Hrstov			18/08/2016 / user: hrstov conf: MAPB50SL D:\yavor\MAP46\offer\offer MAPB50SL			
Check				11/08/2016 / user: hrstov conf: MAPB50SL D:\yavor\MAP46\offer\offer MAPB50SL			
Tech.				11/08/2016 / user: hrstov conf: MAPB50SL D:\yavor\MAP46\offer\offer MAPB50SL			
Conf.				11/08/2016 / user: hrstov conf: MAPB50SL D:\yavor\MAP46\offer\offer MAPB50SL			