

Manual operated directional control valve

Technical specification



Specification		02	03	04	06
Working pressure (MPa)	Port P, A, B	31.5			
	Port T	10			
Max. Flow (L/min)		60	100	300	450
Working fluid		Mineral oil; phosphate-ester			
Fluid temp. (°C)		-20~70			
Viscosity (mm ² /s)		2.8~380			
Weight (kg)		About 1.4	About 3.3	About 8	About 17
Cleanliness	The maximum allowable cleanliness of the oil should be according to 9th degree of Standard NAS1638. It is suggested that the minimum filter rating should be $\beta_{10} \geq 75$.				

Manual operated directional control valve is a directional control valve, by operating the handle, the spool moves in the axial direction to achieve oil loop switching.

Manual operated directional control valve and electrical operated directional control valve are played the same role in the hydraulic system. Easy operation, reliable work, and without the need for electricity.

Model description

Manual operated directional control valve		Remarks	
<p>Specification</p> <p>02 NS 6</p> <p>03 NS 10</p> <p>04 NS 16</p> <p>06 NS 25</p>	<p>Serial number</p>	<p>Seal material</p> <p>Omit NBR Seals</p> <p>V FPM Seals</p>	<p>Omit without damping</p> <p>08 Φ0.8 Damping</p> <p>10 Φ1.0 Damping</p> <p>12 Φ1.2 Damping</p>
<p>Function code</p> <p>Details as following symbol table</p>	<p>Omit Spring return</p> <p>OF With detent</p>	<p>FS - * - * / * * * 50 *</p>	

Manual operated directional control valve

Code symbol

Spring return

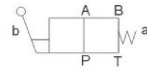
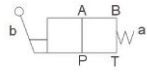

With detent

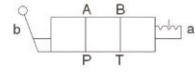
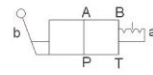
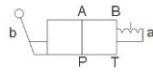

D.9.2

3C2		2B2B		2B2BL		2B2	
3C3		2B3B		2B3BL		2B3	
3C4		2B4B		2B4BL		2B8	
3C5		2B5B		2B5BL			
3C6		2B6B		2B6BL			
3C7		2B7B		2B7BL			
3C9		2B9B		2B9BL		2B2L	
3C10		2B10B		2B10BL		2B3L	
3C11		2B11B		2B11BL		2B8L	
3C12		2B12B		2B12BL			
3C25		2B25B		2B25BL			
3C29		2B29B		2B29BL			

Manual operated directional control valve

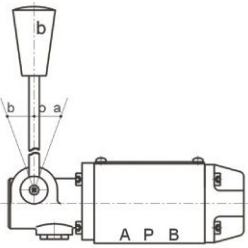
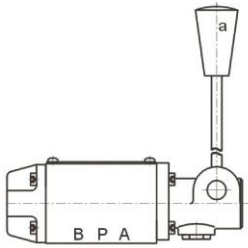

The relationship between the location of the handle and the direction of the oil flow

1. The name of the handle as shown in the picture
2. When the handle is on position b P→B A→T
3. When the handle is on position a P→A B→T
4. Oil flow in the opposite direction with the above-mentioned movement for 02/03:3C5,3C6.
Oil flow in the opposite direction with the above-mentioned movement for 04/06:3C6.
5. The location of the handle is different according to the function. It may be at A or B. Details outline for 03/04/06.

D.9.3

02 Specification Performance curve (Measured at $v=41\text{mm}^2/\text{s}$ and $t=50^\circ\text{C}$)

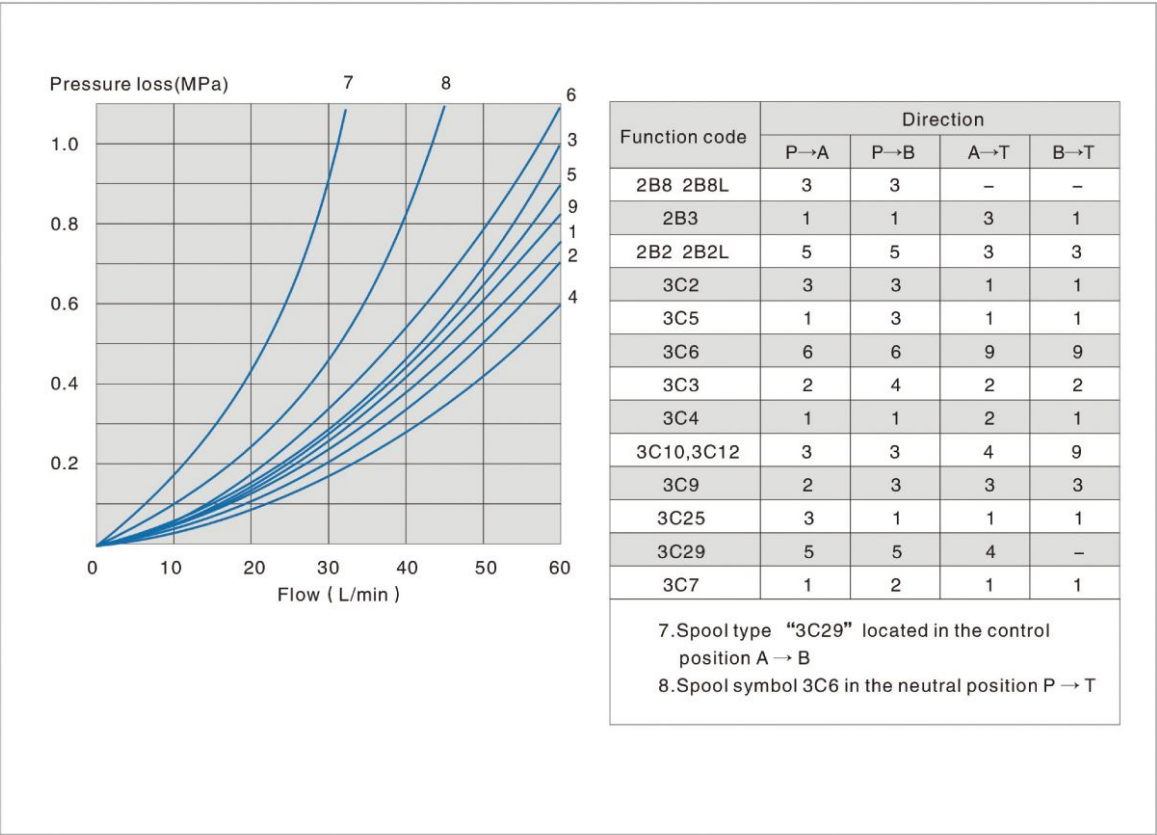

Manual operated directional control valve

02 Specification Working limits (The working limits for directional valve have determined by using solenoids at their operating temperature, 10% under voltage and with no pre-loading of the tank.)

As the plug, the switch function of the valve is determined by the filter. In order to reach the largest flow as shown, we suggest to use full-flow filter 20 μ m. Every force on the valve can also affect the flow. With regard to the four-way valve, the normal flow data as shown is get from the regular use of two directions of the flow (e.g. P to A, and simultaneous return flow from B to T). See tables. If only one flow direction is needed, for example: When a four port valve which is closed up port A or port B, used as a three-way valve, the Maximum flow may be very small in the serious condition.

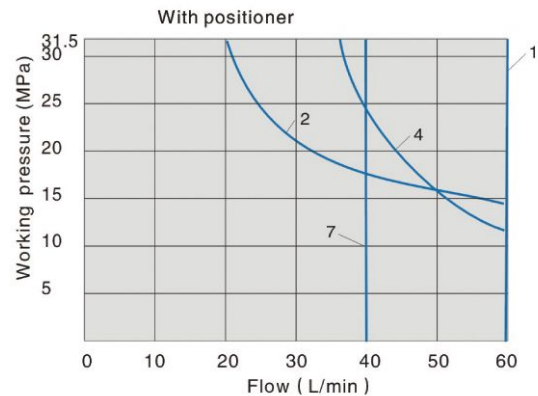
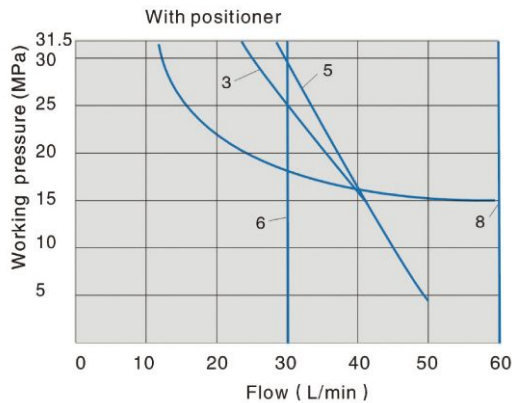
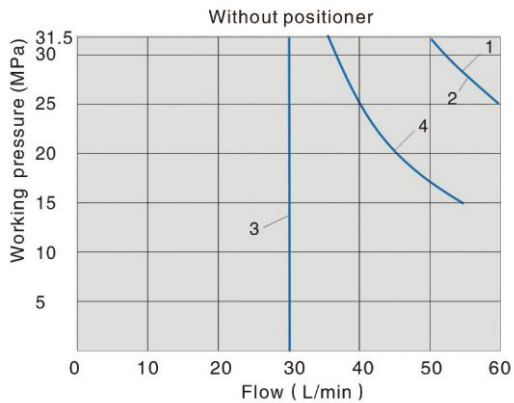

4. Spool symbol "3C6" in the median position P to T
7. Spool symbol "3C29" in the control position A to B

Performance curve		Function code	Performance curve		Function code
With positioner	1	3C2 3C3 2B3 2B2 3C9 3C10 3C6 3C4 3C12 3C29 2B2L	With positioner	1	3C9 3C3 2B3 2B2 2B2L
	2	2B8 2B8L		2	3C2 3C4 3C12 3C10
	3	3C7		3	2B8 2B8L
	4	3C5 3C25		4	3C6
				5	3C5
				6	3C7
				7	3C25
				8	3C29

Manual operated directional control valve



03 Specification Performance curve (Measured at $v=41\text{mm}^2/\text{s}$ and $t=50^\circ\text{C}$)

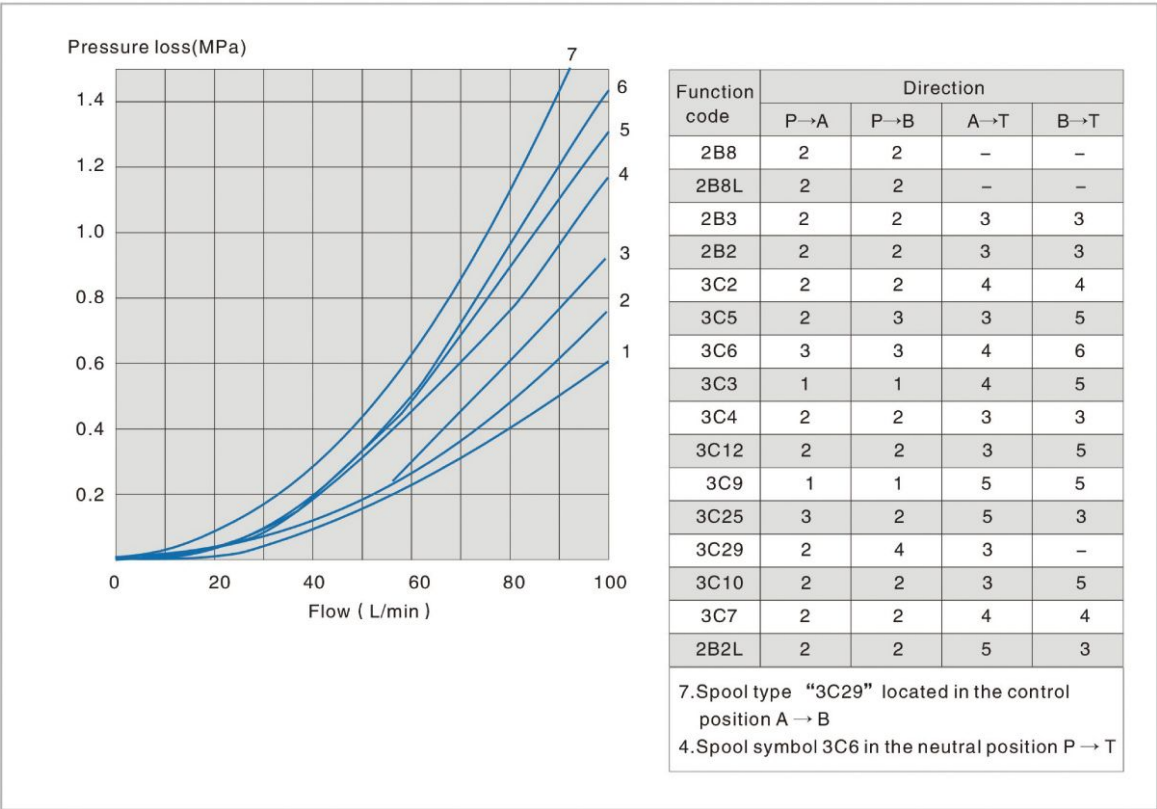

D.9.5

03 Specification Working limits (The working limits for directional valves have determined by using solenoids at their operating temperature, 10% under voltage and with no pre-loading of the tank.)

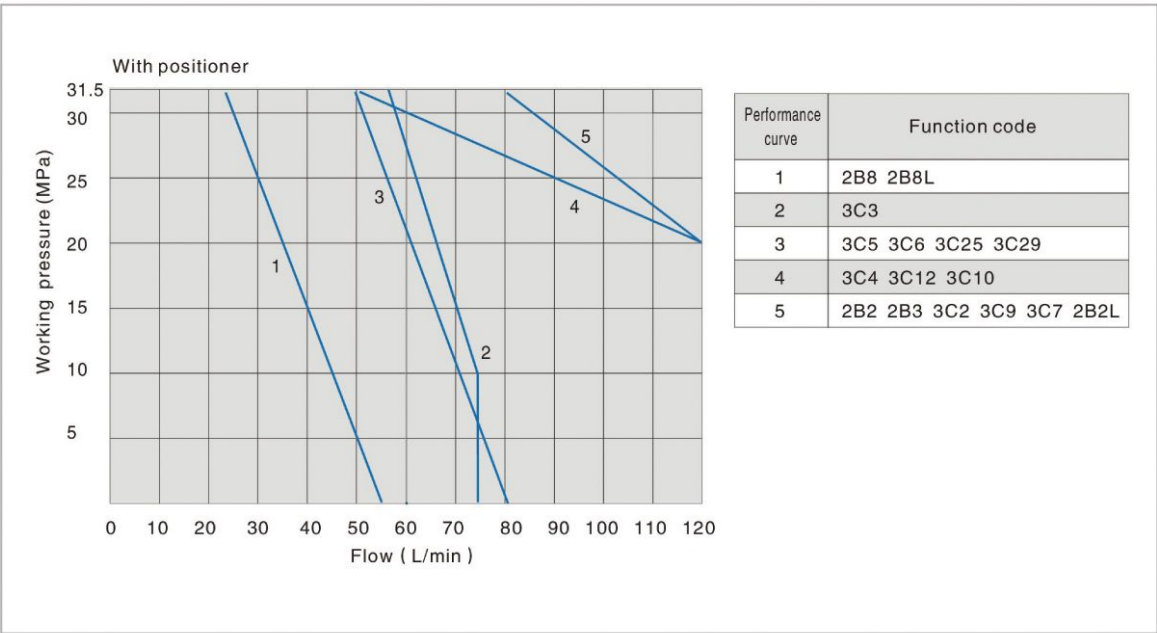

Manual operated directional control valve

04 Specification Performance curve (Measured at $\nu=41\text{mm}^2/\text{s}$ and $t=50^\circ\text{C}$)

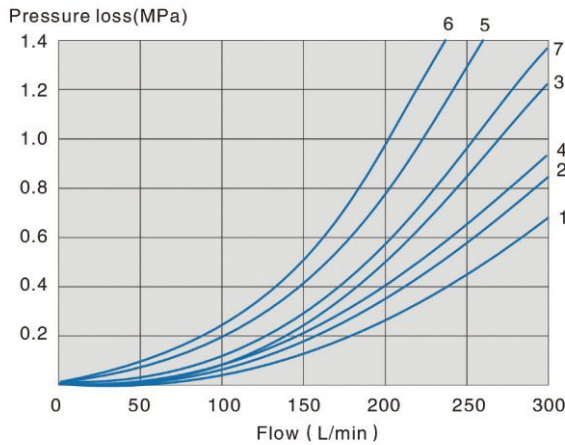

Function code	Direction			
	P→A	P→B	A→T	B→T
3C2 2B2 2B2L	1	1	1	3
3C5	2	2	3	3
3C6	5	1	3	7
3C3 2B3	2	2	3	3
3C7	2	2	3	3
3C4 3C12	1	1	3	3
3C29	2	2	4	-
3C10	2	2	4	-
3C	1	1	4	7

4. Spool symbol 3C6 in the neutral position P → T

04 Specification Working limits (The working limits for directional valves have determined by using solenoids at their operating temperature, 10% under voltage and with no pre-loading of the tank.)

two-way valve With positioner					
Function code	Working pressure (MPa)				
	7	14	21	28	35
	Flow (L/min)				
2B3	300	300	300	260	220
2B2	300	300	210	190	160

two-way valve With positioner					
Function code	Working pressure (MPa)				
	7	14	21	28	35
	Flow (L/min)				
2B2 2B3	300	300	300	260	220

three-way valve With positioner					
Function code	Working pressure (MPa)				
	7	14	21	28	35
	Flow (L/min)				
3C2 3C3 3C4 3C12 3C9 3C29 3C10	300	300	300	300	300
3C5 3C25	300	300	210	190	170
3C6	300	300	220	210	180
3C7	300	260	200	180	170

three-way valve With positioner					
Function code	Working pressure (MPa)				
	7	14	21	28	35
	Flow (L/min)				
3C2 3C3 3C4 3C12 3C9 3C29 3C10	300	300	300	300	300
3C5 3C25	300	300	280	230	230
3C6	300	300	230	230	230
3C7	300	300	250	230	230

Manual operated directional control valve



06 Specification Performance curve (Measured at $v=41\text{mm}^2/\text{s}$ and $t=50^\circ\text{C}$)

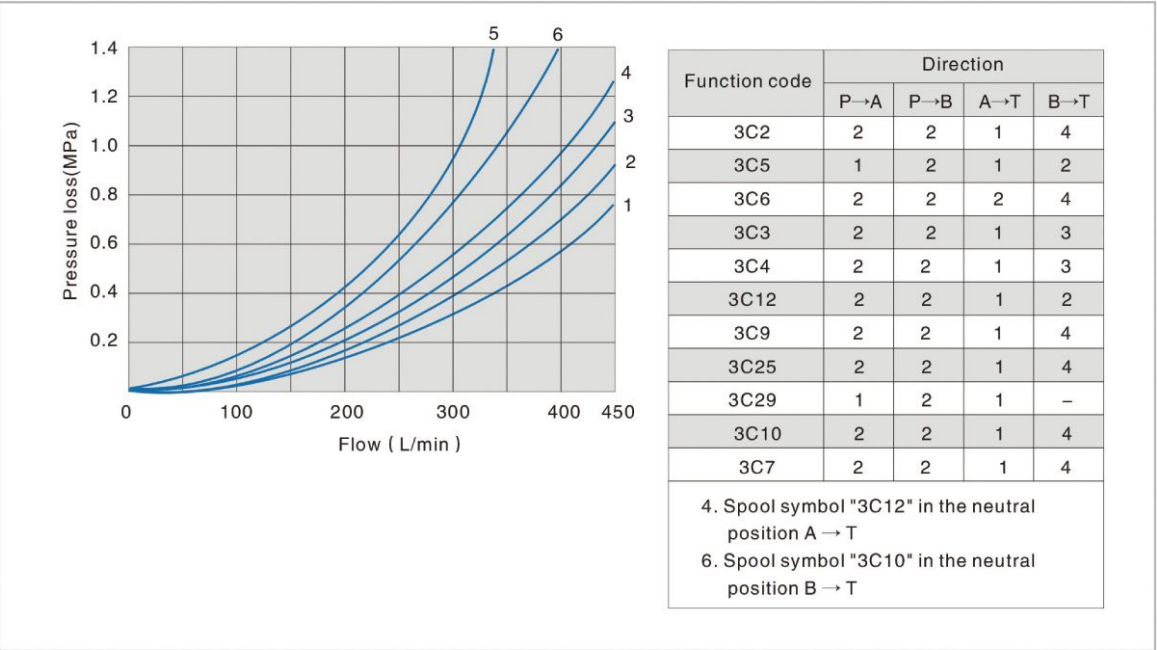

D.9.7

06 Specification Working limits (The working limits for directional valve have determined using solenoids at their operating temperature, 10% under voltage and with no pre-loading of the tank.)

two-way valve With positioner					
Function code	Working pressure (MPa)				
	7	14	21	28	35
	Flow (L/min)				
2B3	450	300	250	200	180
2B2	350	300	275	250	200

two-way valve With positioner					
Function code	Working pressure (MPa)				
	7	14	21	28	35
	Flow (L/min)				
2B3 2B2	450	450	450	450	450

three-way valve With positioner					
Function code	Working pressure (MPa)				
	7	14	21	28	35
	Flow (L/min)				
3C2 3C3 3C4 3C12 3C9 3C29 3C10	450	450	450	450	450
3C5	450	250	200	135	110
3C6	450	330	290	230	180
3C3	450	450	400	400	350
3C25	450	310	240	215	150
3C7	450	310	280	270	200

three-way valve With positioner					
Function code	Working pressure (MPa)				
	7	14	21	28	35
	Flow (L/min)				
3C2 3C5 3C6 3C3 3C4 3C10 3C9 3C25 3C29 3C12	450	450	450	450	450
3C7	450	450	400	350	300

Manual operated directional control valve

02 External dimensions

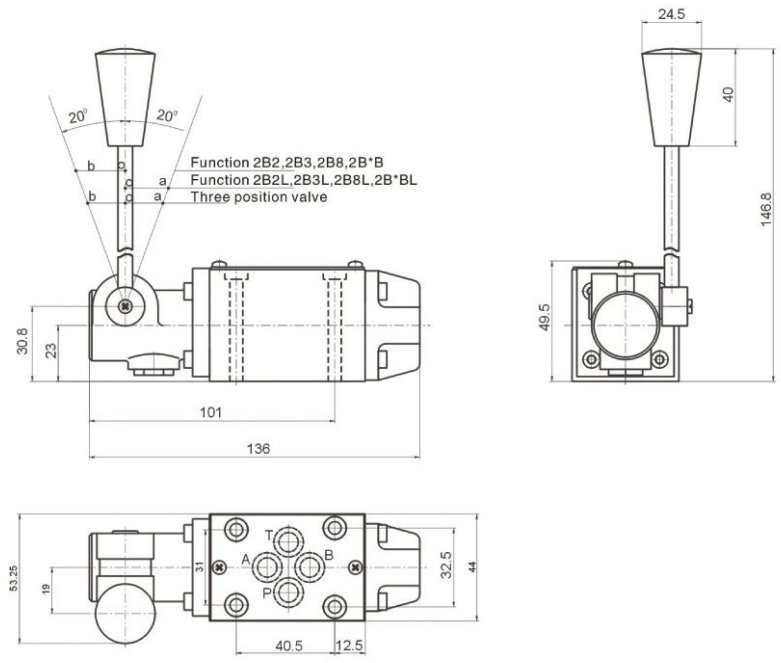

D.9.8

02 Size of subplate oil port

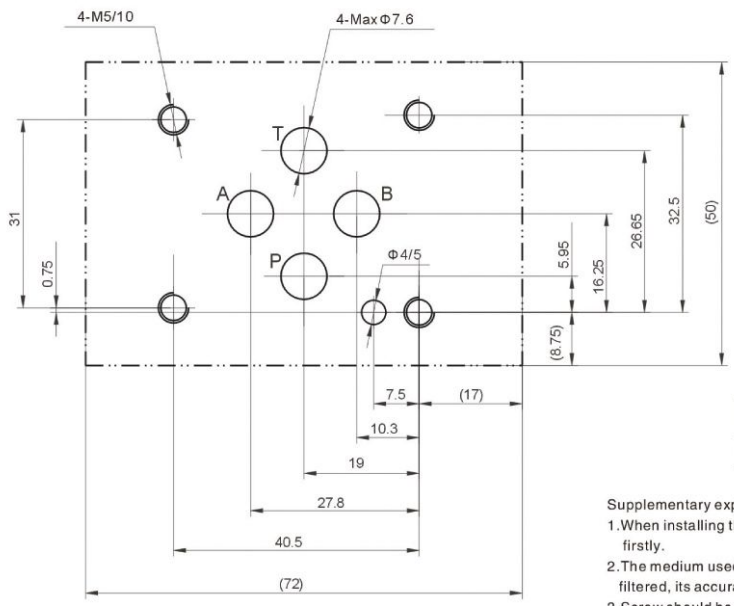

Mounting screw	Amount	Tighten torque
M5x50-10.9	4	9Nm

- Supplementary explanation
- When installing the product, considering horizontal position firstly.
 - The medium used in the hydraulic system must be filtered, its accuracy is at least $20 \mu m$.
 - Screw should be according to the parameters in catalogue.
 - The surface, connecting with the valve, should be Ra0.8 roughness, and 0.01/100mm flatness.

D.9.8

Manual operated directional control valve



03 Spring type External dimensions

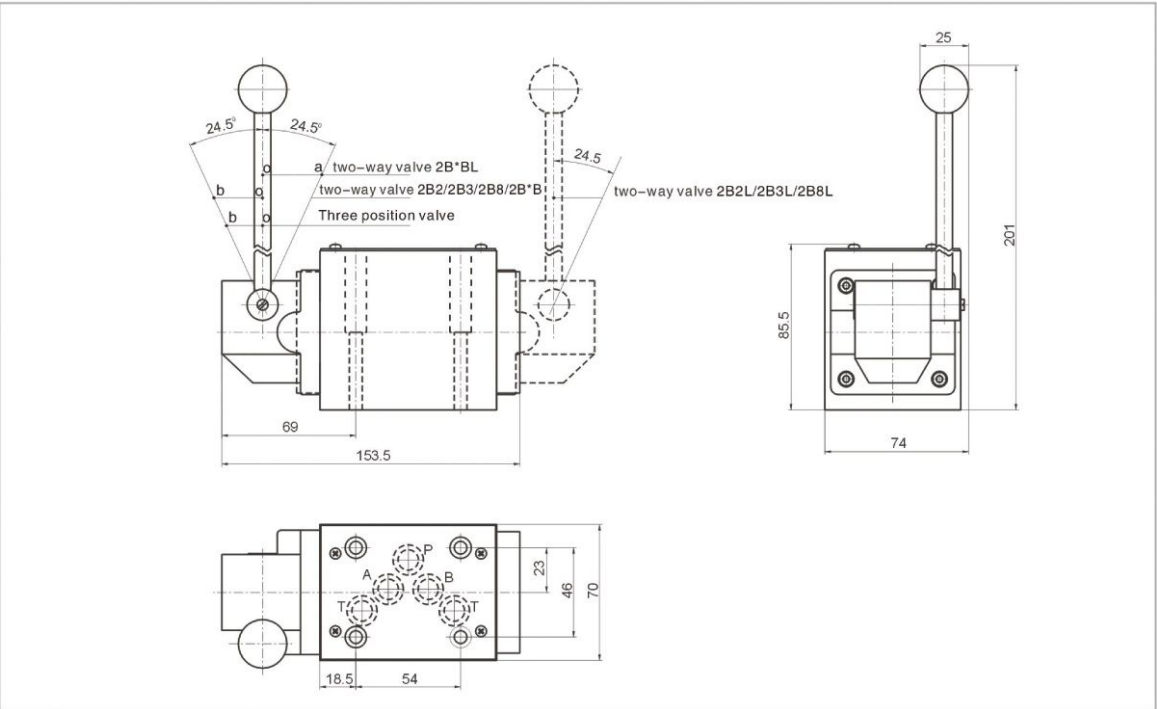

D.9.9

03 Spring type Size of subplate oil port

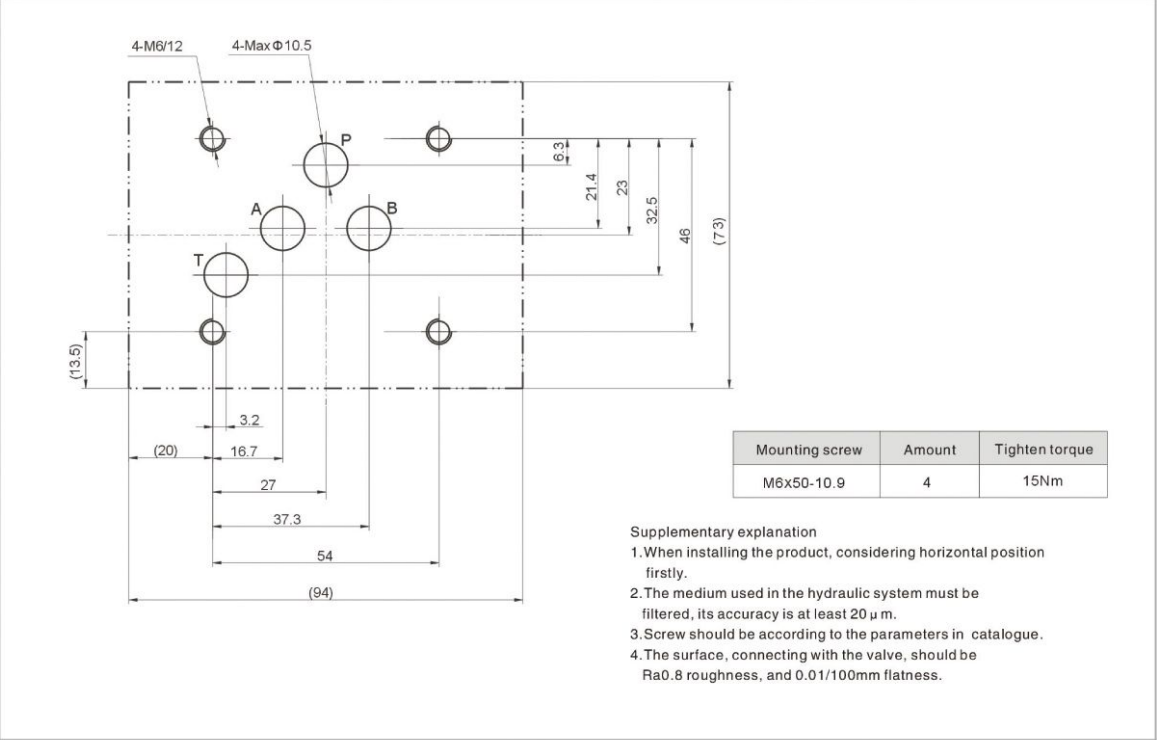

Manual operated directional control valve

03 With detent type External dimensions

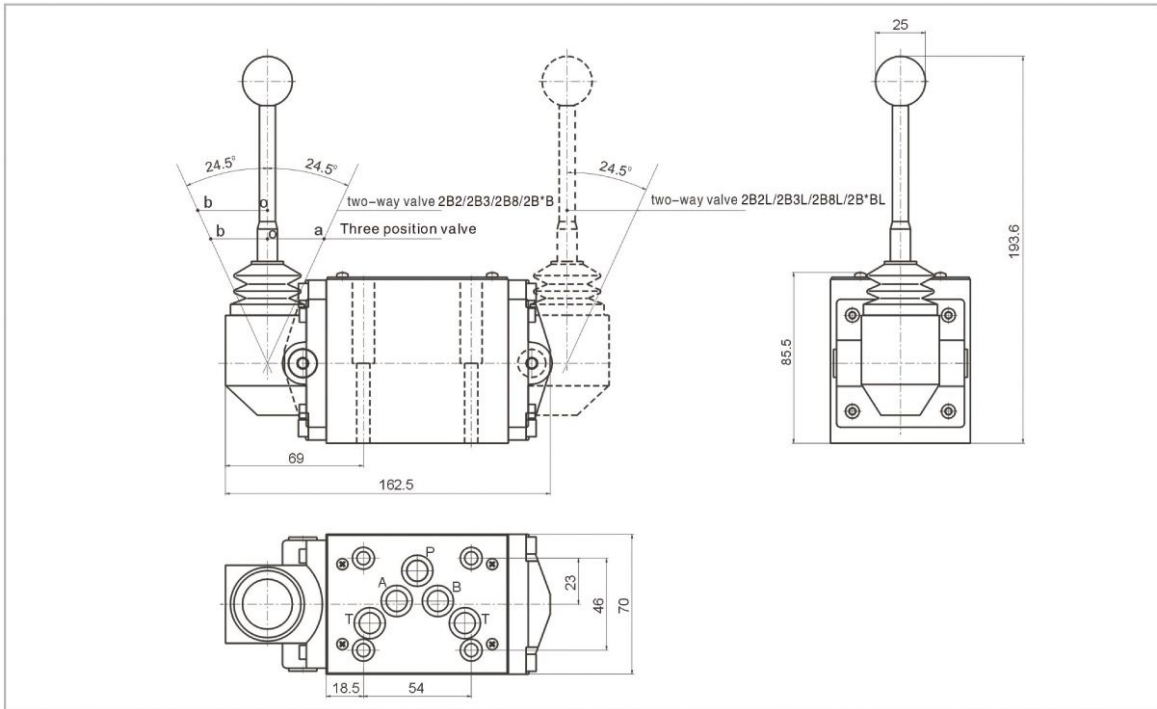

D.9.10

03 With detent type Size of subplate oil port

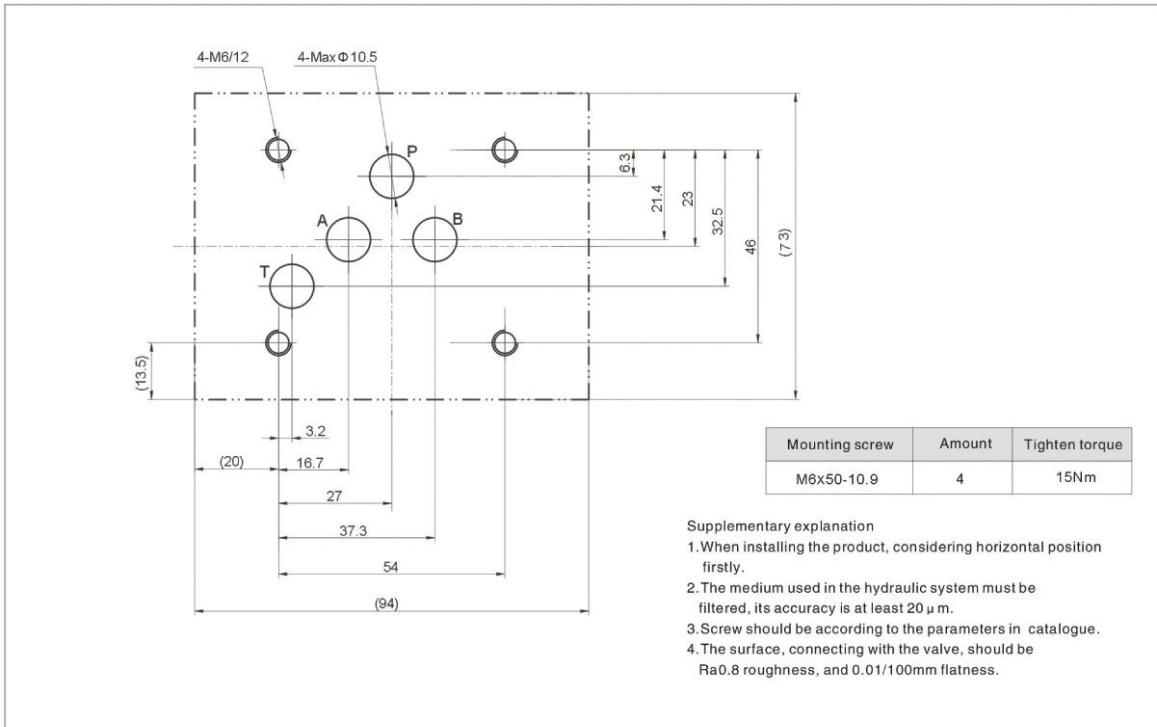

D.9.10

Manual operated directional control valve



04 External dimensions

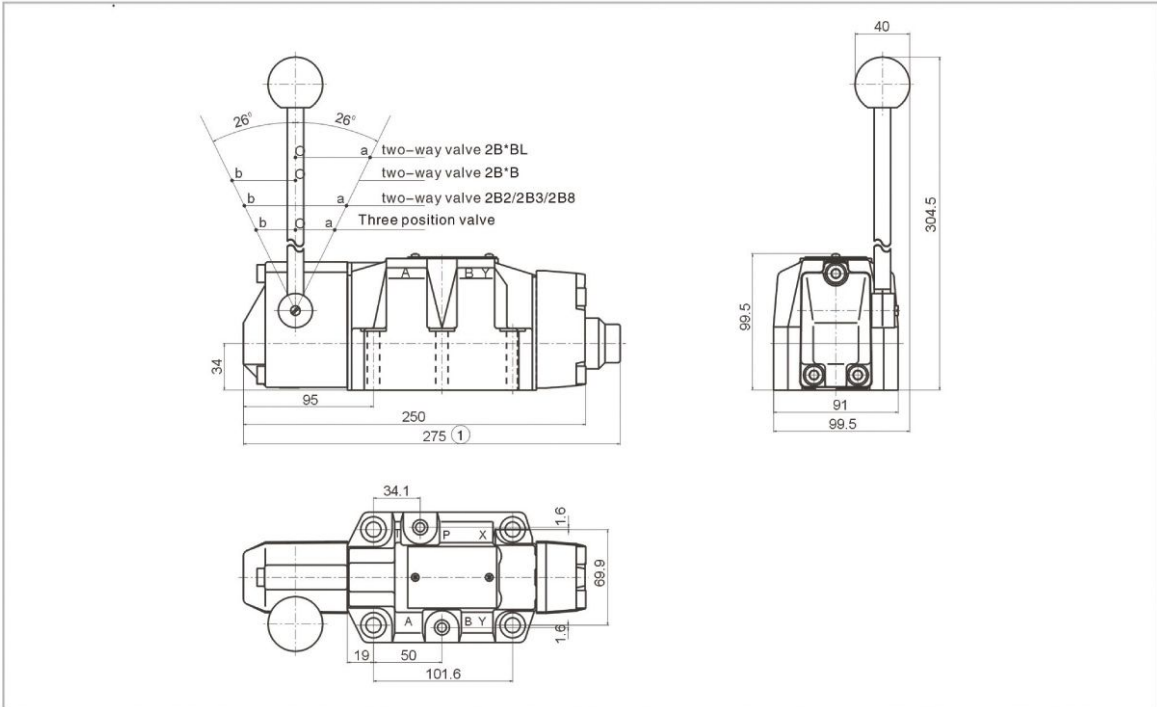

D.9.11

04 Size of subplate oil port

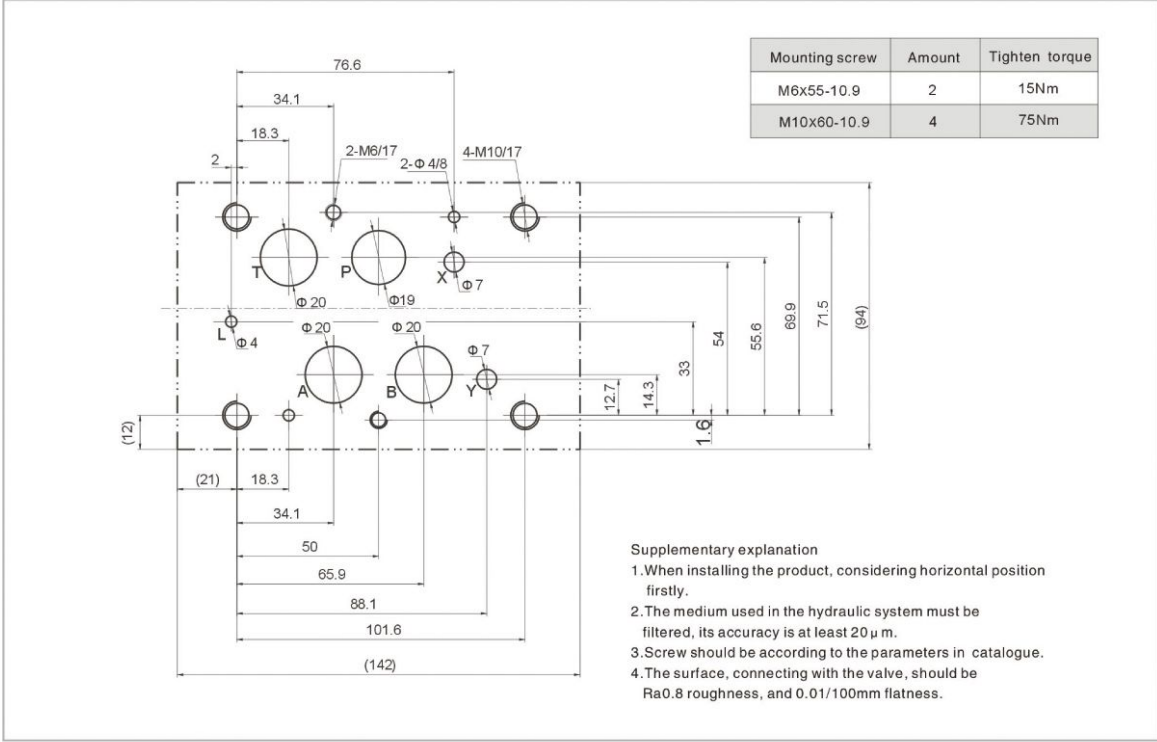

Manual operated directional control valve

06 External dimensions

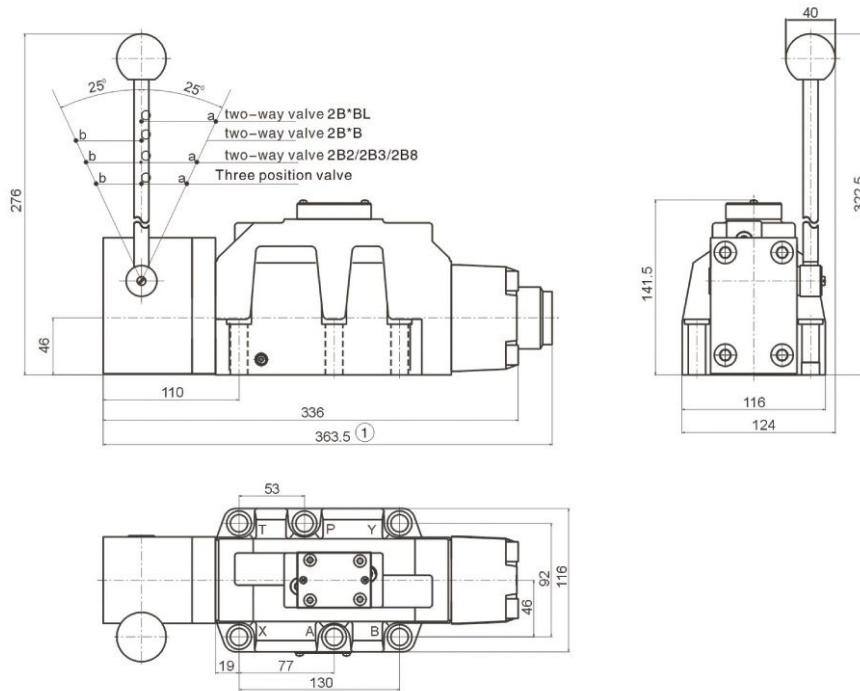

06 Size of subplate oil port

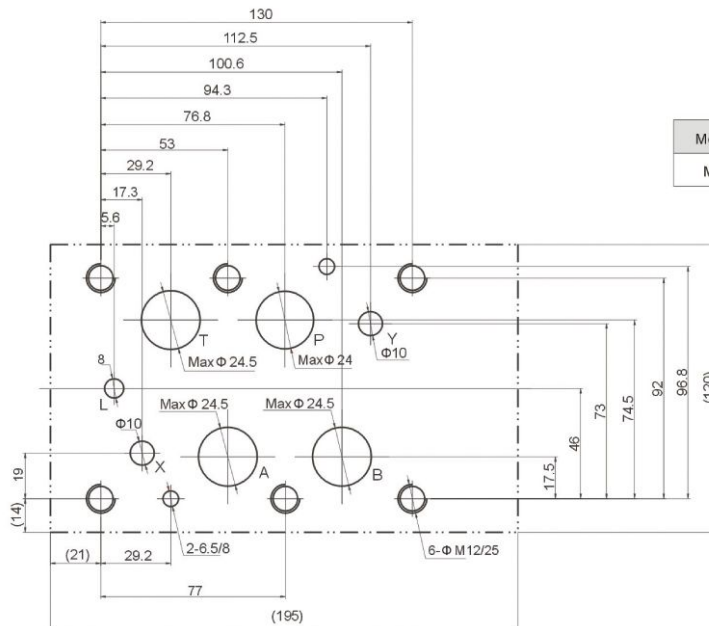

Mounting screw	Amount	Tighten torque
M12x60-10.9	6	130Nm

Supplementary explanation

1. When installing the product, considering horizontal position firstly.
2. The medium used in the hydraulic system must be filtered, its accuracy is at least $20\ \mu\text{m}$.
3. Screw should be according to the parameters in catalogue.
4. The surface, connecting with the valve, should be Ra0.8 roughness, and 0.01/100mm flatness.