



PLANETENMOTOR EPM-K

ORBITAL MOTOR EPM-K

ANWENDUNG

- o Förderbänder
- o Metallbearbeitungsmaschinen
- o Fördertechnik für Roboter
- o Landmaschinen
- o Nahrungsmittelindustrie
- o Textilmaschinen
- o u.a.

APPLICATION

- o Conveyors
- o Metal working machines
- o Feeding mechanism of robots and maipulators
- o Agricultural machines
- o Food industries
- o Textile machines
- o etc.

BAUWEISE UND AUSFÜHRUNGEN

- o Modell: Längsschieberventil, Planetensatz
- o Ovalflansch oder Quadratflansch
- o Anschlüsse: Seitlich, metrisches oder BSPP Gewinde
- o Wellen: Zylindrisch, konisch oder verzahnt
- o Konisches Kegelrollenlager
- o Sonderausführungen

CONSTRUCTION AND OPTIONS

- o Model: Spool valve, gerotor
- o Ovalflange or squareflange
- o Ports: Side ports, metric or BSPP threaded
- o Shafts: Straight, tapered or splined
- o Antifriction conical bearing
- o Other special features

ÜBERSICHT OVERVIEW

Max. Schluckvolumen	Max. Displacement	cm ³ /U	ccm/rev	[in ³ /rev]	396,0 [24.16]
Max. Drehzahl	Max. Speed	U/min	rpm		1010
Max. Drehmoment	Max. Torque	daNm		[in/lb]	55,6 [4921]
Max. Leistungsabgabe	Max. Output	kW		[HP]	8,6 [11.5]
Max. Druckgefälle	Max. Pressure drop	bar		[PSI]	140 [2030]
Max. Ölstrom	Max. Oil flow	l/min	lpm	[GPM]	50 [13.2]
Min. Drehzahl	Min. Speed	U/min	rpm		10
Hydrauliköl	Pressure fluid				HLP (DIN 51524) oder or HM (ISO 6743/4)
Öltemperatur	Temperature range	° C		[° F]	-40 ÷ 140 [-40 ÷ 284]
Optimalviskosität	Optimal viscosity range	mm ² /s		[SUS]	20 ÷ 75 [98 ÷ 347]
Filtrierung	Filtration				ISO code 20/16 (min. empfohlene Filtrierung recommended filtration 25 µm)

ÖLSTROM LECKÖLLEITUNG OIL FLOW DRAIN LINE

Druckgefälle Pressure drop bar [PSI]	Viskosität Viscosity mm ² /s [SUS]	Ölstrom Oilflow l/min lpm [GPM]
100 [1450]	20 [98]	2,5 [.660]
	35 [164]	1,8 [.476]
140 [2030]	20 [98]	3,5 [.925]
	35 [164]	2,8 [.740]

DRUCKVERLUST PRESSURE LOSSES

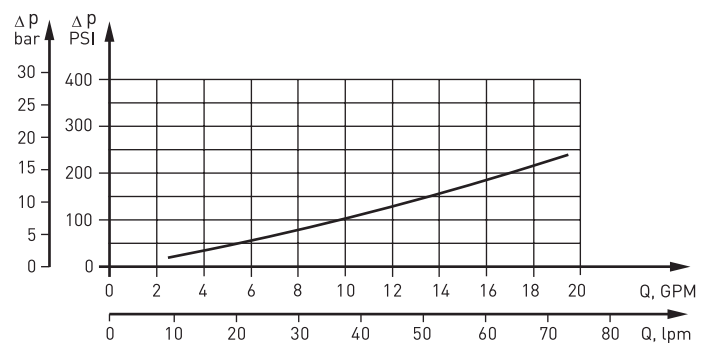

TECHNISCHE DATEN

TECHNICAL DATA

Typ Type		EPM-K 50	EPM-K 80	EPM-K 100	EPM-K 125	EPM-K 160	EPM-K 200	EPM-K 250	EPM-K 315	EPM-K 400
Schluckvolumen Displacement	cm ³ /U ccm/rev [in ³ /rev]	49,5 [3.02]	79,2 [4.83]	99,0 [6.04]	123,8 [7.55]	158,4 [9.66]	198,0 [12.10]	247,5 [15.10]	316,8 [19.30]	396,0 [24.16]
Max. Drehzahl Max. Speed U/min RPM	Dauerbetrieb Continuous	808	505	404	323	252	202	160	126	100
	Int. * Int. *	1010	630	505	403	315	252	202	157	126
Max. Drehmoment Max. Torque daNm [lb-in]	Dauerbetrieb Continuous	7,0 [619]	10,8 [956]	14,4 [1274]	17,0 [1504]	22,0 [1974]	27,5 [2434]	30,1 [2664]	31,7 [2805]	40,8 [3611]
	Int. * Int. *	9,2 [914]	14,6 [1292]	18,3 [1619]	22,9 [2026]	29,3 [2593]	36,6 [3239]	37,6 [3328]	44,0 [3894]	55,6 [4921]
	Spitze ** Peak **	13,6 [1203]	21,4 [1894]	26,1 [2310]	32,6 [2885]	41,8 [3700]	52,2 [4620]	51,5 [4558]	64,3 [5691]	80,0 [7080]
Max. Leistungsabgabe Max. Output kW [HP]	Dauerbetrieb Continuous	5,2 [7.00]	5,2 [7.00]	5,2 [7.00]	5,2 [7.00]	5,2 [7.00]	5,2 [7.00]	4,6 [6.20]	3,4 [4.60]	3,4 [4.60]
	Int. * Int. *	8,6 [11.50]	8,6 [11.50]	8,6 [11.50]	8,6 [11.50]	8,6 [11.50]	8,6 [11.50]	7,0 [9.30]	5,8 [7.80]	5,8 [7.80]
Max. Druckgefälle Max. Pressure drop bar [PSI]	Dauerbetrieb Continuous	105 [1520]	105 [1520]	105 [1520]	105 [1520]	105 [1520]	105 [1520]	90 [1305]	70 [1015]	70 [1015]
	Int. * Int. *	140 [2030]	140 [2030]	140 [2030]	140 [2030]	140 [2030]	140 [2030]	115 [1665]	105 [1520]	105 [1520]
	Spitze ** Peak **	215 [3120]	215 [3120]	215 [3120]	215 [3120]	215 [3120]	215 [3120]	170 [2470]	170 [2470]	170 [2470]
Max. Ölstrom Max. Oil flow l/min lpm [GPM]	Dauerbetrieb Continuous	40 [10.5]	40 [10.5]	40 [10.5]	40 [10.5]	40 [10.5]	40 [10.5]	40 [10.5]	40 [10.5]	40 [10.5]
	Int. * Int. *	50 [13.2]	50 [13.2]	50 [13.2]	50 [13.2]	50 [13.2]	50 [13.2]	50 [13.2]	50 [13.2]	50 [13.2]
Max. Eingangsdruck Max. Inlet pressure bar [PSI]	Dauerbetrieb Continuous	140 [2030]	140 [2030]	140 [2030]	140 [2030]	140 [2030]	140 [2030]	140 [2030]	140 [2030]	140 [2030]
	Int. * Int. *	175 [2540]	175 [2540]	175 [2540]	175 [2540]	175 [2540]	175 [2540]	175 [2540]	175 [2540]	175 [2540]
	Spitze ** Peak **	225 [3260]	225 [3260]	225 [3260]	225 [3260]	225 [3260]	225 [3260]	225 [3260]	225 [3260]	225 [3260]
Max. Rücklaufdruck mit Leckölleitung oder max. Druck in der Leckölleitung Max. Return pressure with drain line or max. pressure in drain line bar [PSI]	Dauerb. Cont. 0 - 100 U/min RPM	150 [2180]	150 [2180]	150 [2180]	150 [2180]	150 [2180]	150 [2180]	150 [2180]	150 [2180]	150 [2180]
	Dauerb. Cont. 100 - 300 U/min RPM	75 [1090]	75 [1090]	75 [1090]	75 [1090]	75 [1090]	75 [1090]	75 [1090]	75 [1090]	75 [1090]
	Dauerb. Cont. 300 - 600 U/min RPM	50 [725]	50 [725]	50 [725]	50 [725]	50 [725]	50 [725]	50 [725]	50 [725]	50 [725]
	Dauerb. Cont. > 600 U/min RPM	20 [290]	20 [290]	20 [290]	20 [290]	20 [290]	20 [290]	20 [290]	20 [290]	20 [290]
	Int.* Int.* 0 - max. U/min RPM	15 [220]	15 [220]	15 [220]	15 [220]	15 [220]	15 [220]	15 [220]	15 [220]	15 [220]
Max. Anlaufdruck mit unbelasteter Welle Min. Starting pressure with unloaded shaft	bar [PSI]	10 [145]	10 [145]	10 [145]	10 [145]	10 [145]	10 [145]	10 [145]	10 [145]	10 [145]
Min. Anlaufmoment Min. Starting torque	daNm [lb-in]	5,8 [513]	9,1 [805]	12,2 [1079]	14,5 [1283]	19,5 [1725]	24,8 [2195]	27,5 [2433]	29,0 [2567]	35,9 [3278]
Min. Drehzahl *** Min. Speed ***	U/min RPM	10	10	10	10	10	10	10	10	10
Gewicht Weight	kg [lb]	5,0 [11.1]	5,1 [11.2]	5,3 [11.7]	5,4 [11.9]	5,6 [12.3]	5,8 [12.8]	6,0 [13.2]	6,3 [13.9]	6,8 [15.0]

- * Intermittierend: Betrieb max. 10% pro Minute
- ** Spitze: max. 1% pro Minute
- *** Für Drehzahlen kleiner der min. Drehzahl sprechen Sie uns bitte an.
- Intermittierende Druckgefälle und Ölströme dürfen nicht gleichzeitig erreicht werden.
- Minimale Viskosität 13 mm²/s [70 SUS] bei 50 °C [122 °F]
- Maximale Öltemperatur während des Betriebs 82 °C [180 °F]
- Die Lebensdauer der Motoren kann erhöht werden, wenn die Antriebswelle 10-15 Minuten vor voller Belastung frei läuft.

- * Intermittent: Working max. 10% per minute
- ** Peak: max. 1% per minute
- *** For speeds lower than given, please consult us.
- Int. speed and pressure should not occur simultaneously.
- Recommended min. oil viscosity 13 mm²/s [70 SUS] at 50 °C [122 °F]
- Recommended max. system operating temperature is 82 °C [180 °F]
- To assure optimum motor life fill with fluid prior to loading and run at moderate load and speed for 10-15 minutes.

BESTELLCODE ORDER CODE

EPM-K	1	2	3	4	5	6
-------	---	---	---	---	---	---

1.	Montageflansch Mounting flange
frei omit	Ovalflansch, zwei Befestigungslöcher Oval mount two holes
Q	Quadratflansch, vier Gewindebohrungen Square mount four bolts

2.	Schluckvolumen Displacement
50	49,5 cm ³ /U ccm/rev. [3.02 in ³ /rev]
80	79,2 cm ³ /U ccm/rev. [4.83 in ³ /rev]
100	99,0 cm ³ /U ccm/rev. [6.04 in ³ /rev]
125	123,8 cm ³ /U ccm/rev. [7.55 in ³ /rev]
160	158,4 cm ³ /U ccm/rev. [9.66 in ³ /rev]
200	198,0 cm ³ /U ccm/rev. [12.10 in ³ /rev]
250	247,5 cm ³ /U ccm/rev. [15,1 in ³ /rev]
315	316,8 cm ³ /U ccm/rev. [19.30 in ³ /rev]
400	396,0 cm ³ /U ccm/rev. [24.16 in ³ /rev]

3.	Abtriebswelle (Zul. Momentabgabe darf nicht überschritten werden) Shaft (Permissible output torque should not be exceeded)
C	Zylindrisch Ø25, Passfeder 8x7x32 DIN6885 Straight Ø25, parallel key 8x7x32 DIN6885
CO	Zylindrisch Ø1", Passfeder 1/4"x1/4"x1 1/4" BS246 Straight Ø1", parallel key 1/4"x1/4"x1 1/4" BS246
SH	Verzahnt Ø25,32 BS2059 (SAE 6 B) Splined Ø25,32, BS2059 (SAE 6 B)
SA	Verzahnt Ø24,5 B25x22 DIN5482 Splined Ø24,5 B25x22 DIN5482
K	Konisch 1:10, Ø28,56, Passfeder B5x5x14 DIN6885 Tapered 1:10, Ø28,56, parallel key B5x5x14 DIN6885

4.	Anschlüsse Drain ports
frei omit	BSPP (ISO295)
M	Metrisch (ISO262) Metric (ISO 262)

5.	Sonderausführungen Special features
FR	Leichtlaufausführung Free running
R	Drehrichtung umgedreht Reverse rotation
P	Lackiert (Farbe auf Anfrage) Paint (colour on request)
PC	Korrosionsschutzfarbe (Farbe auf Anfrage) Corrosion protected paint (colour on request)
PS	Speziallackierung (Anschlussflächen blank / Farbe auf Anfrage) Paint (non painted feeding surfaces / colour on request)
PCS	Korrosionsschutzfarbe Spezial (Anschlussflächen blank / Farbe auf Anfrage) Corrosion prot. paint special (non painted feeding surfaces / colour on request)

6.	Design Serie Design series
frei omit	Betriebsspezifisch Factory specified

1. MONTAGEFLANSCH

1. MOUNTING FLANGE

Standard: Ovalflansch, 2 Befestigungslöcher
 Standard: Oval mount, 2 holes

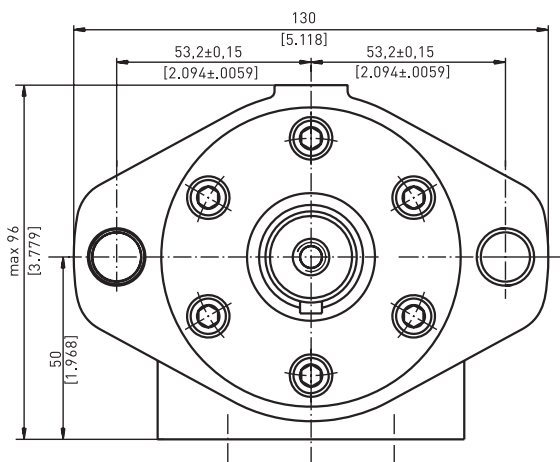

Option Q: Quadratflansch, 4 Gewindebohrungen
 Option Q: Square mount, 4 bolts

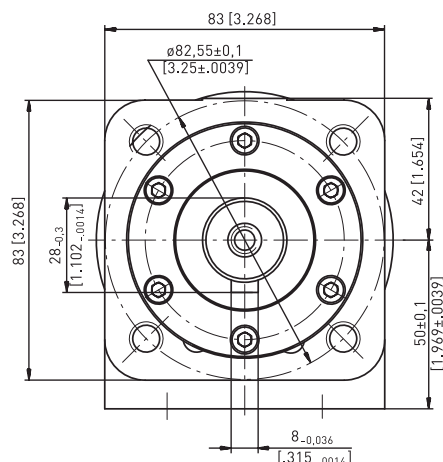

3. ABTRIEBSWELLE

3. SHAFT

Option C: Zylindrisch Ø25 mm
 Option C: Straight Ø 25 mm

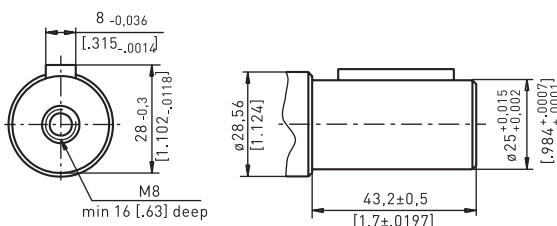

Option CO: Zylindrisch Ø1"
 Option CO: Straight Ø1"

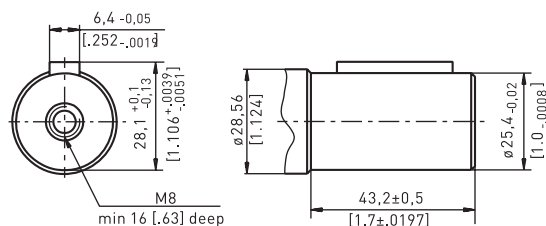

Option SH: Verzahnt SAE 6 B
 Option SH: Splined SAE 6 B

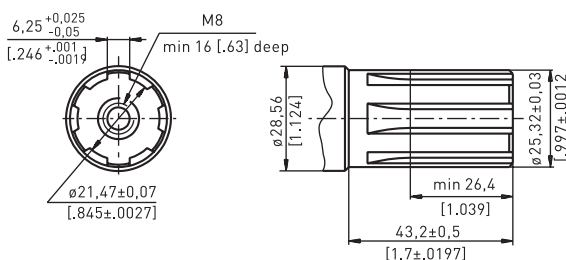

Option SA: Verzahnt B25x22h9
 Option SA: Splined B25x22h9

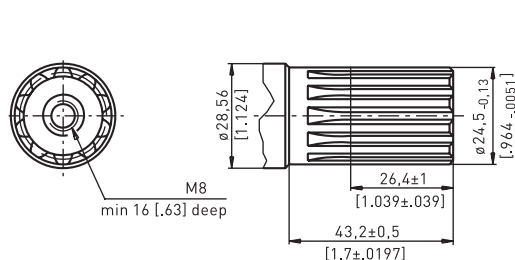

Option K: Konisch 1:10, Ø28,56 mm
 Option K: Tapered 1:10, Ø28,56 mm

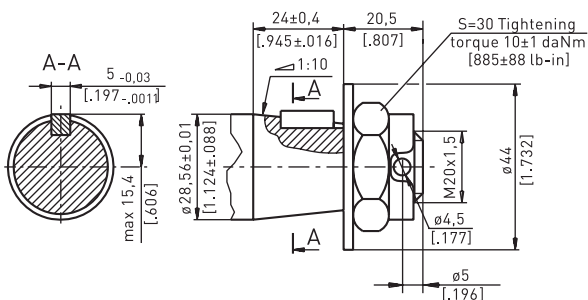

Zulässige Drehmomentabgabe
 Permissible output torque

Zulässige Drehmomentabgabe je nach Wellentyp Permissible output torque based on shaft type daNm [lb-in]				
C	CO	SH	SA	K
34 [3010]	34 [3010]	40 [3540]	40 [3540]	40 [3540]



EINBAUMAß DIMENSION

Ovalflansch
Oval mount

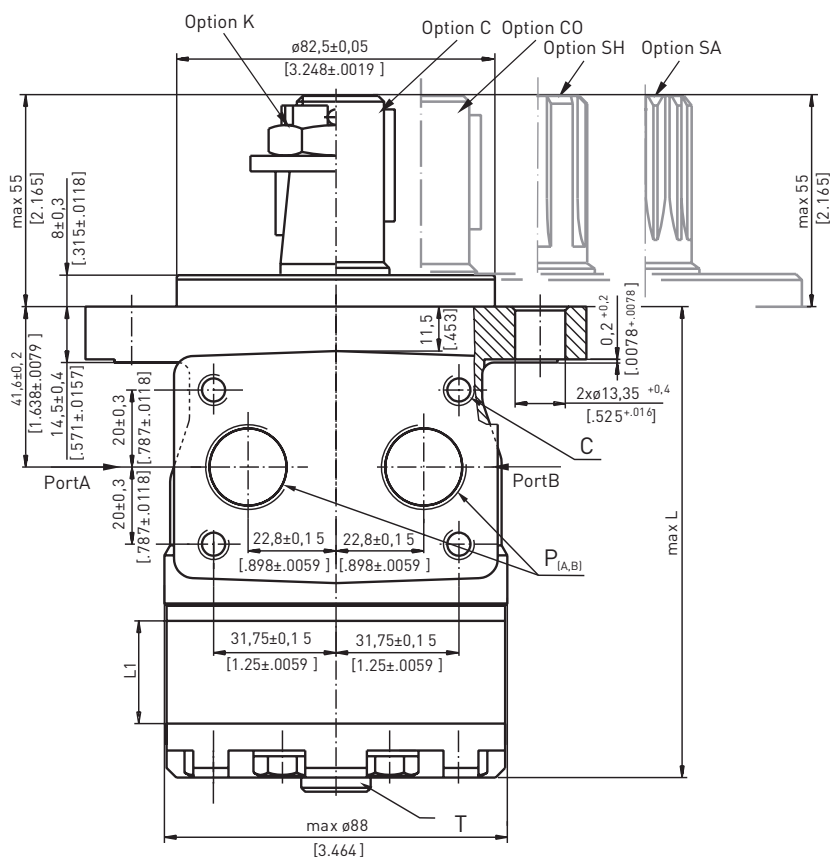

C: 4xM8 - 13mm [.51 in] tief deep
P (A,B): 2xG1/2 oder 2xM22x1,5 - 15mm [.59 in] tief deep
T: G1/4 oder M14x1,5 - 8,5 mm [.47 in] tief deep

Quadratflansch
Square mount

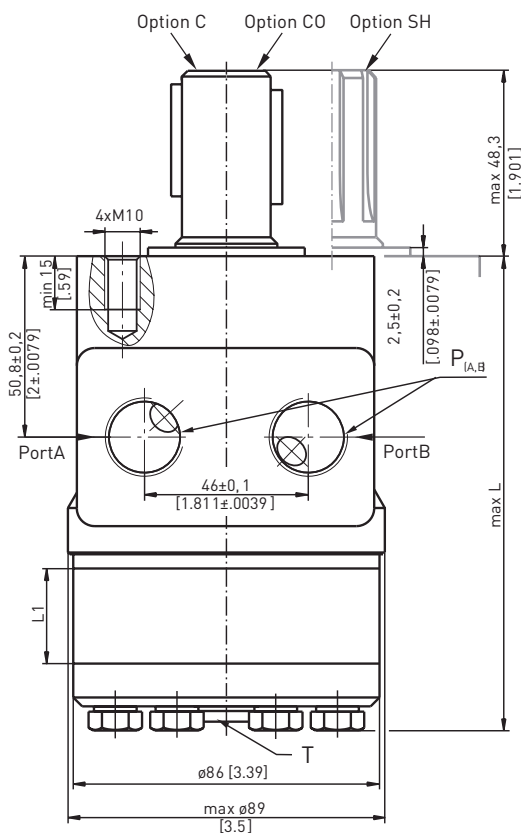

Typ	Type	L, mm [in]	Typ	Type	L, mm [in]	L ₁ , mm [in]
EPM-K	50	102,5 [4.04]	EPM-K-Q	50	113,5 [4.47]	6,67 [.26]
EPM-K	80	106,5 [4.19]	EPM-K-Q	80	117,5 [4.63]	10,67 [.42]
EPM-K	100	109,0 [4.29]	EPM-K-Q	100	120,0 [4.72]	13,33 [.52]
EPM-K	125	112,5 [4.43]	EPM-K-Q	125	123,5 [4.86]	16,67 [.66]
EPM-K	160	117,0 [4.61]	EPM-K-Q	160	128,0 [5.04]	21,33 [.84]
EPM-K	200	122,5 [4.82]	EPM-K-Q	200	133,5 [5.26]	26,67 [1.05]
EPM-K	250	129,0 [5.08]	EPM-K-Q	250	140,0 [5.51]	33,33 [1.31]
EPM-K	315	138,5 [5.45]	EPM-K-Q	315	149,5 [5.89]	42,67 [1.68]
EPM-K	400	149,0 [5.87]	EPM-K-Q	400	160,0 [6.30]	53,33 [2.10]

Standarddrehung
mit Blick auf Abtriebswelle
Druck auf Anschluss A - rechtsdrehend
Druck auf Anschluss B - linksdrehend

Reversierdrehung (5. - Option R)
mit Blick auf Abtriebswelle
Druck auf Anschluss A - linksdrehend
Druck auf Anschluss B - rechtsdrehend

Standard rotation
Viewed from shaft end
Port A pressurised- right running
Port B pressurised- left running

Reverse rotation (5. - Option R)
Viewed from shaft end
Port A pressurised- left running
Port B pressurised- right running

5. SONDERAUSFÜHRUNGEN

5. SPECIAL FEATURES

Option FR: Leichtlaufausführung Option FR: Free running

FR Motoren haben größere Abstände zwischen den rotierenden Teilen im Planetensatz. Dadurch lässt sich die Abtriebswelle mit weniger mechanischem Widerstand drehen. Der größere Abstand verbessert auch die Schmierung der Abnutzungsflächen im Planetensatz. Weitere Vorteile ist eine längere Lebensdauer bei hohen Drehzahlen (größer 300 U/min) und geringem Druckabfall. Der volumetrische Wirkungsgrad kann bei diesen Motoren etwas geringer ausfallen.

FR motors are with increased clearance at all friction parts, allowing the shaft to rotate more freely with less mechanical drag. The increased clearance also improves lubrication of the wear surfaces of gear set and friction parts. Additional advantages of FR versions are prolonging of the life of the hydraulic motors at high speeds, as well as the possibility to use them in systems with wide variation of loading. FR series motors are designed to operate with high speed (over than 300 RPM) and low pressure drop. Volumetric efficiency may be reduced slightly.

WEITERE TECHNISCHE INFORMATIONEN

FURTHER TECHNICAL INFORMATION

Angaben zu Wellenbelastungen, Wellendichtungsdrücken und Leistungsdiagramme entnehmen Sie bitte unserem Katalog EPM (ab Seite 1-2-11).

For informations about permissible shaft loads, permissible shaft seal pressure and function diagrams, please check our EPM-catalogue (incipient from page (1-2-11)).