



PLANETENMOTOR EPML

ORBITAL MOTOR EPML

ANWENDUNG

- o Förderbänder
- o Metallbearbeitungsmaschinen
- o Fördertechnik für Roboter
- o Landmaschinen
- o Nahrungsmittelindustrie
- o Textilmaschinen
- o u.a.

APPLICATION

- o Conveyors
- o Metal working machines
- o Feeding mechanism of robots and maipulators
- o Agricultural machines
- o Food industries
- o Textile machines
- o etc.

BAUWEISE UND AUSFÜHRUNGEN

- o Modell: Längsschieberventil, Planetensatz
- o Ovalflansch oder Quadratflansch
- o Anschlüsse: Seitlich, metrisches oder BSPP Gewinde
- o Wellen: Zylindrisch, konisch oder verzahnt
- o Konisches Kegelrollenlager
- o Sonderausführungen

CONSTRUCTION AND OPTIONS

- o Model: Spool valve, gerotor
- o Ovalflange or squareflange
- o Ports: Side ports, metric or BSPP threaded
- o Shafts: Straight, tapered or splined
- o Antifriction conical bearing
- o Other special features

ÜBERSICHT OVERVIEW

Max. Schluckvolumen	Max. Displacement	cm ³ /U	ccm/rev	[in ³ /rev]	396,0 [24.16]
Max. Drehzahl	Max. Speed	U/min	rpm		1515
Max. Drehmoment	Max. Torque	daNm		[in/lb]	59,0 [5222]
Max. Leistungsabgabe	Max. Output	kW		[HP]	17,5 [23.5]
Max. Druckgefälle	Max. Pressure drop	bar		[PSI]	175 [2540]
Max. Ölstrom	Max. Oil flow	l/min	lpm	[GPM]	75 [20]
Min. Drehzahl	Min. Speed	U/min	rpm		10
Hydrauliköl	Pressure fluid				HLP (DIN 51524) oder or HM (ISO 6743/4)
Öltemperatur	Temperature range	° C		[° F]	-40 ÷ 140 [-40 ÷ 284]
Optimalviskosität	Optimal viscosity range	mm ² /s		[SUS]	20 ÷ 75 [98 ÷ 347]
Filtrierung	Filtration				ISO code 20/16 (min. empfohlene Filtrierung recommended filtration 25 µm)

ÖLSTROM LECKÖLLEITUNG OIL FLOW DRAIN LINE

Druckgefälle Pressure drop bar [PSI]	Viskosität Viscosity mm ² /s [SUS]	Ölstrom Oilflow l/min lpm [GPM]
100 [1450]	20 [98]	2,5 [.660]
	35 [164]	1,8 [.476]
140 [2030]	20 [98]	3,5 [.925]
	35 [164]	2,8 [.740]

DRUCKVERLUST PRESSURE LOSSES

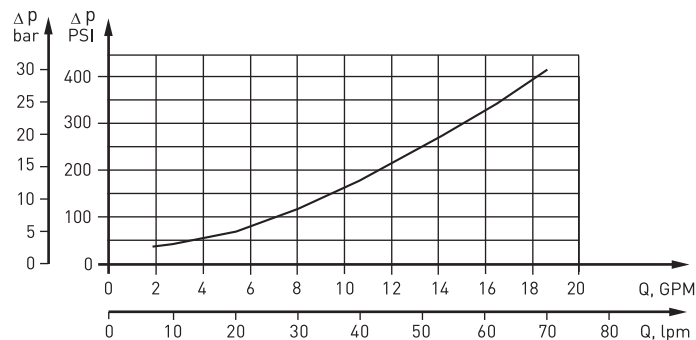

TECHNISCHE DATEN

TECHNICAL DATA

Typ Type		EPML 50	EPML 80	EPML 100	EPML 125	EPML 160	EPML 200	EPML 250	EPML 315	EPML 400
Schluckvolumen Displacement	cm ³ /U ccm/rev [in ³ /rev]	49,5 [3.02]	79,2 [4.83]	99,0 [6.04]	123,8 [7.55]	158,4 [9.66]	198,0 [12.10]	247,5 [15.10]	316,8 [19.30]	396,0 [24.16]
Max. Drehzahl Max. Speed U/min RPM	Dauerbetrieb Continuous	1210	755	605	485	378	303	242	190	150
	Int. * Int. *	1515	945	755	605	472	378	303	236	189
Max. Drehmoment Max. Torque daNm [lb-in]	Dauerbetrieb Continuous	9,4 [832]	15,1 [1336]	19,3 [1708]	23,7 [2100]	31,3 [2770]	36,6 [3240]	47,0 [4160]	48,6 [4300]	50,0 [4425]
	Int. * Int. *	11,9 [1054]	19,5 [1725]	23,7 [2097]	29,8 [2637]	37,8 [3345]	45,6 [4035]	58,3 [5160]	56,0 [4956]	59,0 [5222]
	Spitze ** Peak **	14,0 [1240]	22,0 [1947]	27,0 [2390]	36,5 [3230]	42,0 [3717]	53,0 [4700]	67,0 [5930]	85,0 [7523]	85,4 [7560]
Max. Leistungsabgabe Max. Output kW [HP]	Dauerbetrieb Continuous	9,9 [13.30]	9,9 [13.30]	9,9 [13.30]	9,9 [13.30]	11,7 [15.70]	10,3 [13.80]	9,8 [13.10]	7,6 [10.20]	6,6 [8.90]
	Int. * Int. *	12,5 [16.80]	12,5 [16.80]	12,5 [16.80]	12,5 [16.80]	12,5 [16.80]	12,5 [16.80]	12,5 [16.80]	10,5 [14.00]	8,5 [11.40]
Max. Druckgefälle Max. Pressure drop bar [PSI]	Dauerbetrieb Continuous	140 [2030]	140 [2030]	140 [2030]	140 [2030]	140 [2030]	140 [2030]	140 [2030]	120 [1300]	95 [1015]
	Int. * Int. *	175 [2540]	175 [2540]	175 [2540]	175 [2540]	175 [2540]	175 [2540]	175 [2540]	140 [2030]	115 [1665]
	Spitze ** Peak **	225 [3260]	225 [3260]	225 [3260]	225 [3260]	225 [3260]	225 [3260]	225 [3260]	225 [3260]	180 [2610]
Max. Ölstrom Max. Oil flow l/min lpm [GPM]	Dauerbetrieb Continuous	60 [16.0]	60 [16.0]	60 [16.0]	60 [16.0]	60 [16.0]	60 [16.0]	60 [16.0]	60 [16.0]	60 [16.0]
	Int. * Int. *	75 [20.0]	75 [20.0]	75 [20.0]	75 [20.0]	75 [20.0]	75 [20.0]	75 [20.0]	75 [20.0]	75 [20.0]
Max. Eingangsdruck Max. Inlet pressure bar [PSI]	Dauerbetrieb Continuous	175 [2540]	175 [2540]	175 [2540]	175 [2540]	175 [2540]	175 [2540]	175 [2540]	175 [2540]	175 [2540]
	Int. * Int. *	200 [2900]	200 [2900]	200 [2900]	200 [2900]	200 [2900]	200 [2900]	200 [2900]	200 [2900]	200 [2900]
	Spitze ** Peak **	225 [3260]	225 [3260]	225 [3260]	225 [3260]	225 [3260]	225 [3260]	225 [3260]	225 [3260]	225 [3260]
Max. Rücklaufdruck ohne Leckölleitung oder max. Druck in der Leckölleitung Max. Return pressure without drain line or max. pressure in drain line bar [PSI]	Dauerb. Cont. 0 - 100 U/min RPM	100 [1450]	100 [1450]	100 [1450]	100 [1450]	100 [1450]	100 [1450]	100 [1450]	100 [1450]	100 [1450]
	Dauerb. Cont. 100 - 300 U/min RPM	50 [725]	50 [725]	50 [725]	50 [725]	50 [725]	50 [725]	50 [725]	50 [725]	50 [725]
	Dauerb. Cont. 300 - 600 U/min RPM	25 [365]	25 [365]	25 [365]	25 [365]	25 [365]	25 [365]	25 [365]	25 [365]	25 [365]
	Dauerb. Cont. > 600 U/min RPM	15 [220]	15 [220]	15 [220]	15 [220]	15 [220]	15 [220]	15 [220]	15 [220]	15 [220]
	Int.* Int.* 0 - max. U/min RPM	100 [1450]	100 [1450]	100 [1450]	100 [1450]	100 [1450]	100 [1450]	100 [1450]	100 [1450]	100 [1450]
Max. Rücklaufdruck mit Leckölleitung Max. Return pressure with drain line bar [PSI]	Dauerbetrieb Continuous	175 [2540]	175 [2540]	175 [2540]	175 [2540]	175 [2540]	175 [2540]	175 [2540]	175 [2540]	175 [2540]
	Int. * Int. *	200 [2900]	200 [2900]	200 [2900]	200 [2900]	200 [2900]	200 [2900]	200 [2900]	200 [2900]	200 [2900]
	Spitze ** Peak **	225 [3260]	225 [3260]	225 [3260]	225 [3260]	225 [3260]	225 [3260]	225 [3260]	225 [3260]	225 [3260]
Max. Anlaufdruck mit unbelasteter Welle Max. Starting pressure with unloaded shaft	bar [PSI]	10 [145]	10 [145]	10 [145]	9 [131]	8 [116]	7 [100]	6 [87]	5 [73]	5 [73]
Min. Anlaufmoment Min. Starting torque	daNm [lb-in]	7,7 [681]	13 [1150]	16,8 [1487]	21,0 [1860]	28,0 [2478]	32,2 [2850]	41,4 [3665]	43,0 [3805]	44,0 [3900]
Min. Drehzahl *** Min. Speed ***	U/min RPM	10	10	10	10	10	10	10	10	10
Gewicht Weight	kg [lb]	6,8 [15.0]	7,0 [15.4]	7,1 [15.7]	7,2 [15.9]	7,4 [16.3]	7,6 [16.8]	7,8 [17.2]	8,2 [18.0]	8,6 [18.9]

- * Intermittierend; Betrieb max. 10% pro Minute
- ** Spitze: max. 1% pro Minute
- *** Für Drehzahlen kleiner der min. Drehzahl sprechen Sie uns bitte an.
- Intermittierende Druckgefälle und Ölströme dürfen nicht gleichzeitig erreicht werden.
- Minimale Viskosität 13 mm²/s [70 SUS] bei 50 °C [122 °F]
- Maximale Öltemperatur während des Betriebs 82 °C [180 °F]
- Die Lebensdauer der Motoren kann erhöht werden, wenn die Antriebswelle 10-15 Minuten vor voller Belastung frei läuft.

- * Intermittent: Working max. 10% per minute
- ** Peak: max. 1% per minute
- *** For speeds lower than given, please consult us.
- Int. speed and pressure should not occur simultaneously.
- Recommended min. oil viscosity 13 mm²/s [70 SUS] at 50 °C [122 °F]
- Recommended max. system operating temperature is 82 °C [180 °F]
- To assure optimum motor life fill with fluid prior to loading and run at moderate load and speed for 10-15 minutes.

BESTELLCODE ORDER CODE

EPML	1	2	3	4	5	6	7
------	---	---	---	---	---	---	---

1.	Montageflansch Mounting flange
frei omit	Quadratflansch, vier Befestigungslöcher Square mount four holes
F	Ovalflansch, vier Befestigungslöcher Oval mount four holes

2.	Schluckvolumen Displacement
50	49,5 cm ³ /U ccm/rev. [3.02 in ³ /rev]
80	79,2 cm ³ /U ccm/rev. [4.83 in ³ /rev]
100	99,0 cm ³ /U ccm/rev. [6.04 in ³ /rev]
125	123,8 cm ³ /U ccm/rev. [7.55 in ³ /rev]
160	158,4 cm ³ /U ccm/rev. [9.66 in ³ /rev]
200	198,0 cm ³ /U ccm/rev. [12.10 in ³ /rev]
250	247,5 cm ³ /U ccm/rev. [15,10 in ³ /rev]
315	316,8 cm ³ /U ccm/rev. [19.30 in ³ /rev]
400	396,0 cm ³ /U ccm/rev. [24.16 in ³ /rev]

3.	Abtriebswelle (Zul. Momentabgabe darf nicht überschritten werden) Shaft (Permissible output torque should not be exceeded)
C	Zylindrisch Ø25, Passfeder A8x7x32 DIN6885 Straight Ø25, parallel key A8x7x32 DIN6885
CO	Zylindrisch Ø1", Passfeder 1/4"x1/4"x1 1/4" BS246 Straight Ø1", parallel key 1/4"x1/4"x1 1/4" BS246
SH	Verzahnt Ø25,32 BS2059 (SAE 6 B) Splined Ø25,32, BS2059 (SAE 6 B)
SA	Verzahnt Ø24,5 B25x22 DIN5482 Splined Ø24,5 B25x22 DIN5482
CB	Zylindrisch Ø32, Passfeder A10x8x40 DIN6885 Straight Ø25, parallel key A10x8x40 DIN6885
HB	Verzahnt Ø1 1/4", 14 Zähne, ANSI B92.1-1976 Norm Splined Ø1 1/4", 14T, ANSI B92.1-1976 norm
KB	Konisch 1:10, Ø35, Passfeder B6x6x20 DIN6885 Tapered 1:10, Ø35, parallel key B6x6x20 DIN6885

4.	Version Wellendichtung Shaft seal version
frei omit	Standard Wellendichtung Standard shaft seal
U	Hochdruck Wellendichtung High pressure shaft

5.	Anschlüsse Drain ports
frei omit	BSPP (ISO295)
M	Metrisch (ISO262) Metric (ISO 262)

6.	Sonderausführungen Special features
FR	Leichtlaufausführung Free running
R	Drehrichtung umgedreht Reverse rotation
P	Lackiert (Farbe auf Anfrage) Paint (colour on request)
PC	Korrosionsschutzfarbe (Farbe auf Anfrage) Corrosion protected paint (colour on request)
PS	Speziallackierung (Anschlussflächen blank / Farbe auf Anfrage) Paint (non painted feeding surfaces / colour on request)
PCS	Korrosionsschutzfarbe Spezial (Anschlussflächen blank / Farbe auf Anfrage) Corrosion prot. paint special (non painted feeding surfaces / colour on request)

7.	Design Serie Design series
frei omit	Betriebsspezifisch Factory specified

1. MONTAGEFLANSCH

1. MOUNTING FLANGE

Standard: Quadratflansch, 4 Befestigungslöcher
 Standard: Square mount, 4 holes

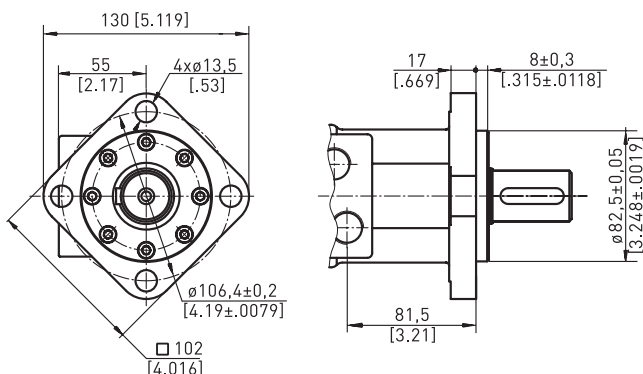

Option F: Ovaleflansch, 4 Befestigungslöcher
 Option F: Oval mount, 4 holes

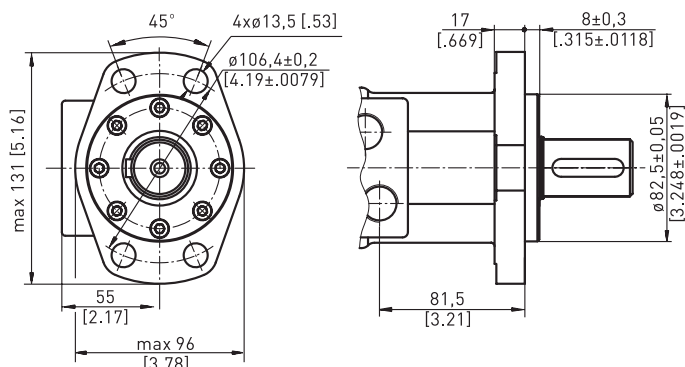

3. ABTRIEBSWELLE

3. SHAFT

Option C: Zylindrisch Ø25 mm
 Option C: Straight Ø 25 mm

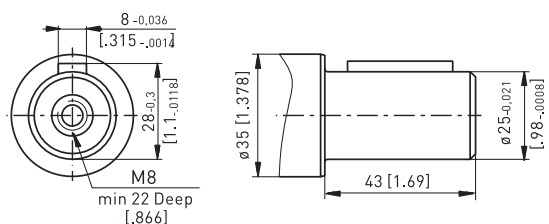

Option C0: Zylindrisch Ø1"
 Option C0: Straight Ø1"

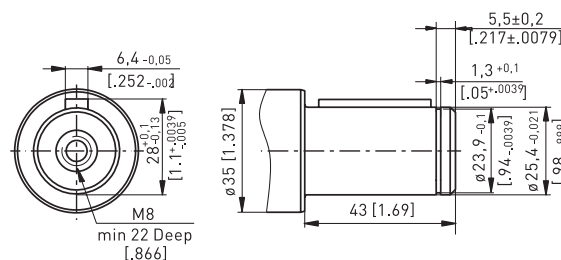

Option SH: Verzahnt SAE 6 B
 Option SH: Splined SAE 6 B

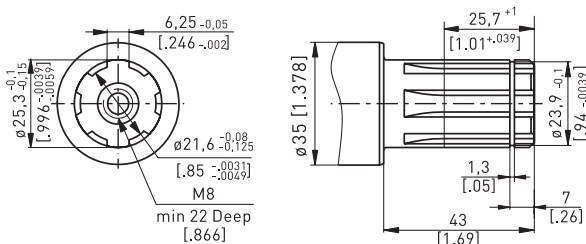

Option SA: Verzahnt B25x22h9
 Option SA: Splined B25x22h9

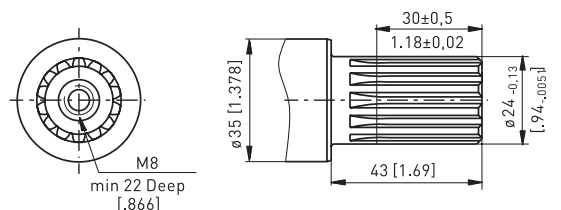

Option CB: Zylindrisch Ø32 mm
 Option CB: Straight Ø 32 mm

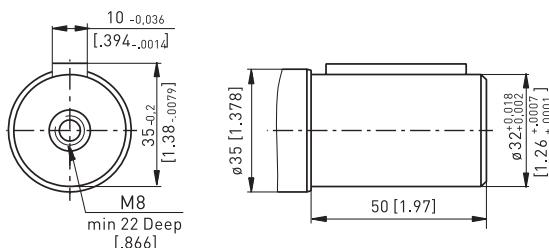

Option HB: Verzahnt Ø1¼", 14 Zähne
 Option HB: Splined Ø1¼", 14T

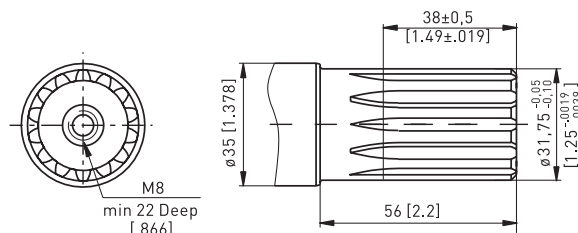

Option KB: Konisch 1:10, Ø35 mm
 Option KB: Tapered 1:10, Ø35 mm

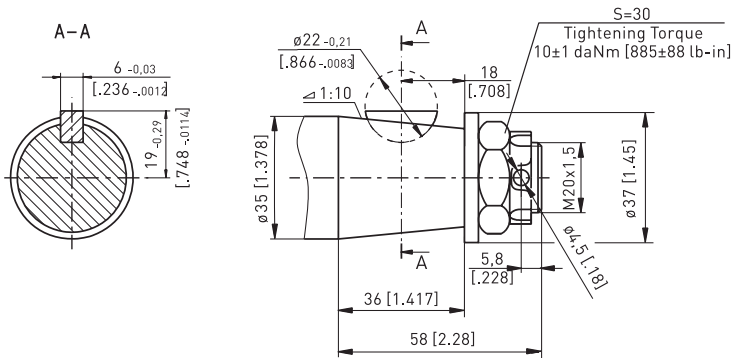

EINBAUMAß DIMENSION

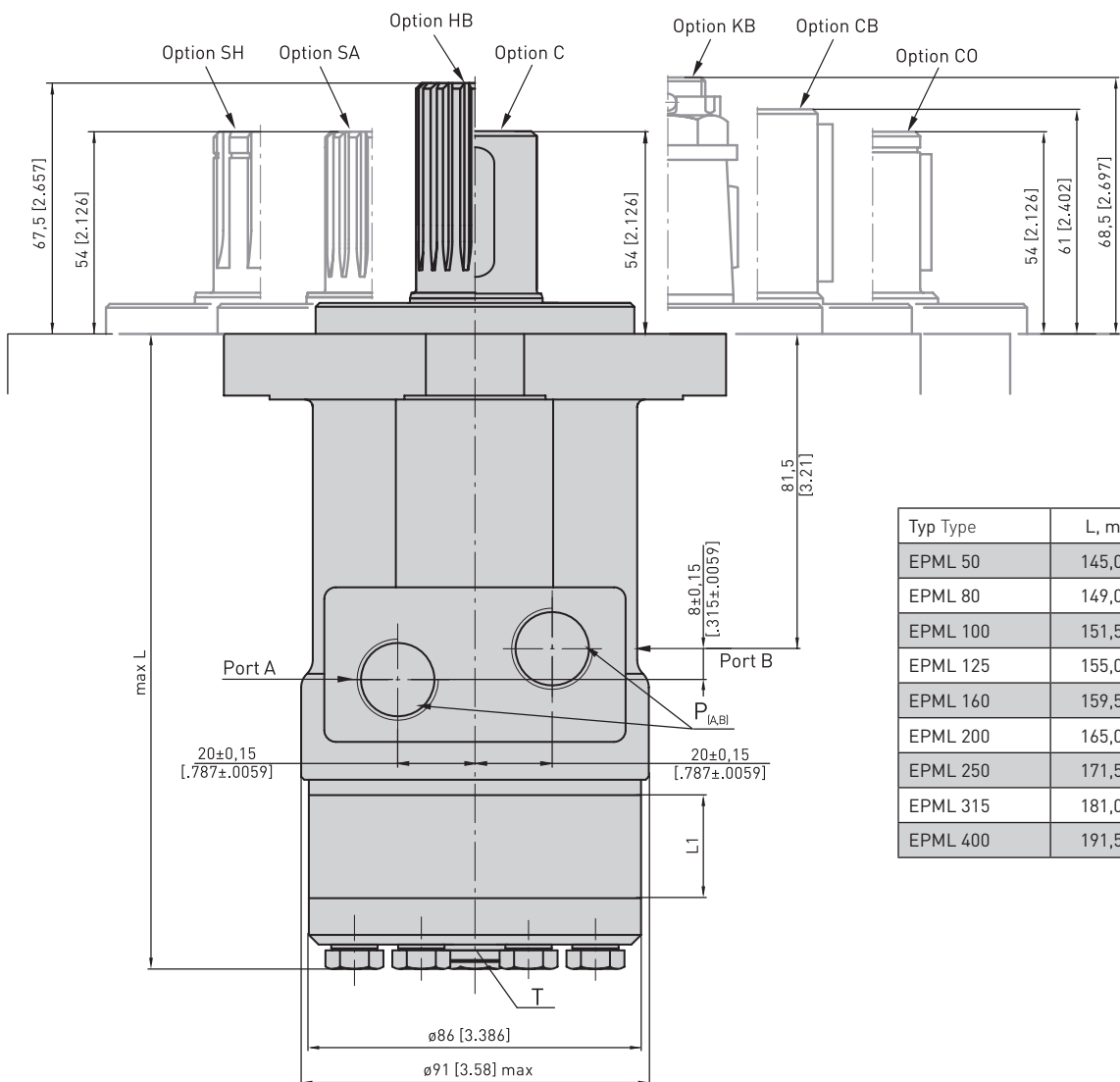

Typ	Type	L, mm [in]	L ₁ , mm [in]
EPML 50		145,0 [5.71]	6,67 [0.26]
EPML 80		149,0 [5.87]	10,67 [0.42]
EPML 100		151,5 [5.96]	13,33 [0.52]
EPML 125		155,0 [6.10]	16,67 [0.66]
EPML 160		159,5 [6.28]	21,33 [0.84]
EPML 200		165,0 [6.49]	26,67 [1.05]
EPML 250		171,5 [6.75]	33,33 [1.31]
EPML 315		181,0 [7.13]	42,67 [1.68]
EPML 400		191,5 [7.54]	53,33 [2.10]

Standarddrehung
 mit Blick auf Abtriebswelle
 Druck auf Anschluss A - rechtsdrehend
 Druck auf Anschluss B - linksdrehend

Reversierdrehung (6. - Option R)
 mit Blick auf Abtriebswelle
 Druck auf Anschluss A - linksdrehend
 Druck auf Anschluss B - rechtsdrehend

Standard rotation
 Viewed from shaft end
 Port A pressurised- right running
 Port B pressurised- left running

Reverse rotation (6. - Option R)
 Viewed from shaft end
 Port A pressurised- left running
 Port B pressurised- right running

P (A,B): 2xG1/2 oder or 2xM22x1,5 - 15mm [.59 in] tief deep
 T: G1/4 oder or M14x1,5 - 8,5 mm [.47 in] tief deep

5. SONDERAUSFÜHRUNGEN

5. SPECIAL FEATURES

Option FR: Leichtlaufausführung

Option FR: Free running

FR Motoren haben größere Abstände zwischen den rotierenden Teilen im Planetensatz. Dadurch lässt sich die Abtriebswelle mit weniger mechanischem Widerstand drehen. Der größere Abstand verbessert auch die Schmierung der Abnutzungflächen im Planetensatz. Weitere Vorteile ist eine längere Lebensdauer bei hohen Drehzahlen (größer 300 U/min) und geringem Druckabfall. Der volumetrische Wirkungsgrad kann bei diesen Motoren etwas geringer ausfallen.

FR motors are with increased clearance at all friction parts, allowing the shaft to rotate more freely with less mechanical drag. The increased clearance also improves lubrication of the wear surfaces of gear set and friction parts. Additional advantages of FR versions are prolonging of the life of the hydraulic motors at high speeds, as well as the possibility to use them in systems with wide variation of loading. FR series motors are designed to operate with high speed (over than 300 RPM) and low pressure drop. Volumetric efficiency may be reduced slightly.

WEITERE TECHNISCHE INFORMATIONEN

FURTHER TECHNICAL INFORMATION

Angaben zu Wellendichtungsdrücken und Leistungsdiagramme entnehmen Sie bitte unserem Katalog EPM (ab Seite 1-2-11).

For informations about permissible shaft seal pressure and function diagrams, please check our EPM-catalogue (incipient from page (1-2-11)).

Zulässige Wellenbelastung EPML

Permissible shaft load EPML

Die Kurven gelten für eine B10-Lebensdauer der Lager von 2000 Stunden
The curves apply to a B10 bearing life of 2000 hours

