



PLANETENMOTOR EPRM-K

ORBITAL MOTOR EPRM-K

ANWENDUNG

- o Förderbänder
- o Metallbearbeitungsmaschinen
- o Fördertechnik für Roboter
- o Landmaschinen
- o Nahrungsmittelindustrie
- o Textilmaschinen
- o u.a.

APPLICATION

- o Conveyors
- o Metal working machines
- o Feeding mechanism of robots and maipulators
- o Agricultural machines
- o Food industries
- o Textile machines
- o etc.

BAUWEISE UND AUSFÜHRUNGEN

- o Modell: Längsschieberventil, Planetensatz
- o Ovalflansch oder Quadratflansch
- o Anschlüsse: Seitlich, metrisches oder BSPP Gewinde
- o Wellen: Zylindrisch, konisch oder verzahnt
- o Konisches Kegelrollenlager
- o Sonderausführungen

CONSTRUCTION AND OPTIONS

- o Model: Spool valve, gerotor
- o Ovalflange or squareflange
- o Ports: Side ports, metric or BSPP threaded
- o Shafts: Straight, tapered or splined
- o Antifriction conical bearing
- o Other special features

ÜBERSICHT OVERVIEW

Max. Schluckvolumen	Max. Displacement	cm ³ /U	ccm/rev	[in ³ /rev]	397,0 [24.4]
Max. Drehzahl	Max. Speed	U/min	rpm		970
Max. Drehmoment	Max. Torque	daNm		[in/lb]	50,0 [4425]
Max. Leistungsabgabe	Max. Output	kW		[HP]	12,8 [17.2]
Max. Druckgefälle	Max. Pressure drop	bar		[PSI]	175 [2540]
Max. Ölstrom	Max. Oil flow	l/min	lpm	[GPM]	75 [18.5]
Min. Drehzahl	Min. Speed	U/min	rpm		10
Hydrauliköl	Pressure fluid				HLP (DIN 51524) oder or HM (ISO 6743/4)
Öltemperatur	Temperature range	° C		[° F]	-40 ÷ 140 [-40 ÷ 284]
Optimalviskosität	Optimal viscosity range	mm ² /s		[SUS]	20 ÷ 75 [98 ÷ 347]
Filtrierung	Filtration				ISO code 20/16 (min. empfohlene Filtrierung recommended filtration 25 µm)

ÖLSTROM LECKÖLLEITUNG OIL FLOW DRAIN LINE

Druckgefälle Pressure drop bar [PSI]	Viskosität Viscosity mm ² /s [SUS]	Ölstrom Oilflow l/min lpm [GPM]
100 [1450]	20 [98]	2,5 [.660]
	35 [164]	1,8 [.476]
140 [2030]	20 [98]	3,5 [.925]
	35 [164]	2,8 [.740]

DRUCKVERLUST PRESSURE LOSSES

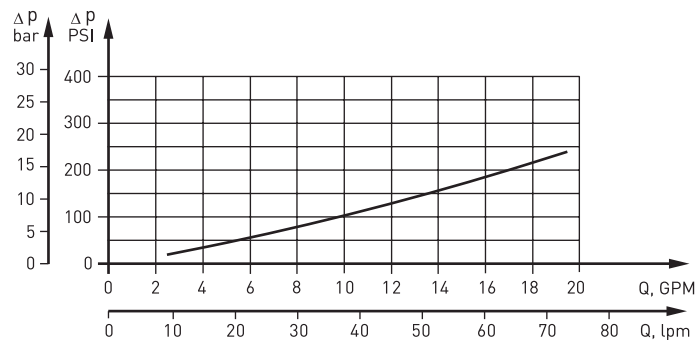

TECHNISCHE DATEN

TECHNICAL DATA

Typ Type		EPRM-K 50	EPRM-K 80	EPRM-K 100	EPRM-K 125	EPRM-K 160	EPRM-K 200	EPRM-K 250	EPRM-K 315	EPRM-K 400
Schluckvolumen Displacement	cm ³ /U ccm/rev [in ³ /rev]	51,5 [3.14]	80,3 [4.90]	99,8 [6.09]	125,5 [7.67]	159,6 [9.74]	199,8 [12.19]	250,1 [15.26]	315,7 [19.26]	397,0 [24.40]
Max. Drehzahl Max. Speed U/min RPM	Dauerbetrieb Continuous	775	750	600	475	375	300	240	190	150
	Int. * Int. *	970	940	750	600	470	375	300	240	185
Max. Drehmoment Max. Torque daNm [lb-in]	Dauerbetrieb Continuous	10,0 [850]	15,7 [1390]	19,8 [1750]	25,0 [2210]	32,0 [2830]	34,0 [3010]	40,0 [3450]	40,0 [3450]	40,0 [3450]
	Int. * Int. *	13,0 [1150]	19,5 [1725]	24,0 [2125]	30,0 [2655]	39,0 [3540]	42,0 [3717]	47,0 [4160]	50,0 [4425]	50,0 [4425]
	Spitze ** Peak **	17,0 [1505]	27,0 [2390]	32,0 [2830]	37,0 [3275]	46,0 [4070]	56,0 [4960]	64,0 [5665]	65,0 [5755]	65,0 [5755]
Max. Leistungsabgabe Max. Output kW [HP]	Dauerbetrieb Continuous	9,0 [12.1]	10,4 [13.9]	10,8 [14.4]	10,8 [14.4]	10,4 [13.9]	8,8 [11.8]	8,1 [10.9]	7,4 [9.9]	6,2 [8.3]
	Int. * Int. *	10,4 [13.9]	12,6 [16.9]	12,8 [17.2]	12,5 [16.8]	11,5 [15.40]	10,2 [13.70]	9,4 [12.60]	7,8 [10.5]	7,1 [9.5]
Max. Druckgefälle Max. Pressure drop bar [PSI]	Dauerbetrieb Continuous	140 [2030]	140 [2030]	140 [2030]	140 [2030]	140 [2030]	125 [1810]	110 [1600]	90 [1300]	75 [1090]
	Int. * Int. *	175 [2540]	175 [2540]	175 [2540]	175 [2540]	175 [2540]	155 [2250]	140 [2030]	125 [1810]	90 [1300]
	Spitze ** Peak **	225 [3260]	225 [3260]	225 [3260]	225 [3260]	225 [3260]	225 [3260]	200 [2900]	150 [2175]	120 [1740]
Max. Ölstrom Max. Oil flow l/min lpm [GPM]	Dauerbetrieb Continuous	40 [10.5]	60 [15.9]	60 [15.9]	60 [15.9]	60 [15.9]	60 [15.9]	60 [15.9]	60 [15.9]	60 [15.9]
	Int. * Int. *	50 [13.2]	75 [18.5]	75 [18.5]	75 [18.5]	75 [18.5]	75 [18.5]	75 [18.5]	75 [18.5]	75 [18.5]
Max. Eingangsdruck Max. Inlet pressure bar [PSI]	Dauerbetrieb Continuous	175 [2540]	175 [2540]	175 [2540]	175 [2540]	175 [2540]	175 [2540]	175 [2540]	175 [2540]	175 [2540]
	Int. * Int. *	200 [2900]	200 [2900]	200 [2900]	200 [2900]	200 [2900]	200 [2900]	200 [2900]	200 [2900]	200 [2900]
	Spitze ** Peak **	225 [3260]	225 [3260]	225 [3260]	225 [3260]	225 [3260]	225 [3260]	225 [3260]	225 [3260]	225 [3260]
Max. Rücklaufdruck mit Leckkölleitung oder max. Druck in der Leckkölleitung Max. Return pressure with drain line or max. pressure in drain line bar [PSI]	Dauerb. Cont. 0 - 100 U/min RPM	150 [2180]	150 [2180]	150 [2180]	150 [2180]	150 [2180]	150 [2180]	150 [2180]	150 [2180]	150 [2180]
	Dauerb. Cont. 100 - 300 U/min RPM	75 [1090]	75 [1090]	75 [1090]	75 [1090]	75 [1090]	75 [1090]	75 [1090]	75 [1090]	75 [1090]
	Dauerb. Cont. 300 - 600 U/min RPM	50 [725]	50 [725]	50 [725]	50 [725]	50 [725]	50 [725]	50 [725]	50 [725]	50 [725]
	Dauerb. Cont. > 600 U/min RPM	20 [290]	20 [290]	20 [290]	20 [290]	20 [290]	20 [290]	20 [290]	20 [290]	20 [290]
	Int.* Int.* 0 - max. U/min RPM	15 [220]	15 [220]	15 [220]	15 [220]	15 [220]	15 [220]	15 [220]	15 [220]	15 [220]
Max. Anlaufdruck mit unbelasteter Welle Min. Starting pressure with unloaded shaft	bar [PSI]	10 [145]	10 [145]	10 [145]	10 [145]	10 [145]	10 [145]	10 [145]	10 [145]	10 [145]
Min. Anlaufmoment Min. Starting torque	daNm b-in)	8,0 [710]	12,0 [1060]	16,0 [1420]	20,0 [1770]	25,0 [2215]	29,0 [2570]	28,0 [2480]	32,0 [2832]	35,0 [3100]
Min. Drehzahl *** Min. Speed ***	U/min RPM	10	10	10	10	10	10	10	10	10
Gewicht Weight	kg [lb]	6,2 [13.7]	6,3 [13.9]	6,6 [14.6]	6,7 [14.8]	6,9 [15.2]	7,4 [16.3]	7,8 [17.2]	8,5 [18.7]	9,3 [20.5]

- * Intermittierend: Betrieb max. 10% pro Minute
- ** Spitze: max. 1% pro Minute
- *** Für Drehzahlen kleiner der min. Drehzahl sprechen Sie uns bitte an.
- Intermittierende Druckgefälle und Ölströme dürfen nicht gleichzeitig erreicht werden.
- Minimale Viskosität 13 mm²/s [70 SUS] bei 50 °C [122 °F]
- Maximale Öltemperatur während des Betriebs 82 °C [180 °F]
- Die Lebensdauer der Motoren kann erhöht werden, wenn die Antriebswelle 10-15 Minuten vor voller Belastung frei läuft.

- * Intermittent: Working max. 10% per minute
- ** Peak: max. 1% per minute
- *** For speeds lower than given, please consult us.
- Int. speed and pressure should not occur simultaneously.
- Recommended min. oil viscosity 13 mm²/s [70 SUS] at 50 °C [122 °F]
- Recommended max. system operating temperature is 82 °C [180 °F]
- To assure optimum motor life fill with fluid prior to loading and run at moderate load and speed for 10-15 minutes.

BESTELLCODE ORDER CODE

EPRM-K	1	2	3	4	5	6
--------	---	---	---	---	---	---

1.	Montageflansch Mounting flange
frei omit	Ovalflansch, zwei Befestigungslöcher Oval mount two holes
Q	Quadratflansch, vier Gewindebohrungen Square mount four bolts

2.	Schluckvolumen Displacement
50	51,5 cm ³ /U ccm/rev. [3.14 in ³ /rev]
80	80,3 cm ³ /U ccm/rev. [4.90 in ³ /rev]
100	99,8 cm ³ /U ccm/rev. [6.09 in ³ /rev]
125	125,7 cm ³ /U ccm/rev. [7.67 in ³ /rev]
160	159,6 cm ³ /U ccm/rev. [9.74 in ³ /rev]
200	199,8 cm ³ /U ccm/rev. [12.19 in ³ /rev]
250	250,1 cm ³ /U ccm/rev. [15,26 in ³ /rev]
315	315,7 cm ³ /U ccm/rev. [19.26 in ³ /rev]
400	397,0 cm ³ /U ccm/rev. [24.40 in ³ /rev]

3.	Abtriebswelle (Zul. Momentabgabe darf nicht überschritten werden) Shaft (Permissible output torque should not be exceeded)
C	Zylindrisch Ø25, Passfeder 8x7x32 DIN6885 Straight Ø25, parallel key 8x7x32 DIN6885
CO	Zylindrisch Ø1", Passfeder 1/4"x1/4"x1 1/4" BS246 Straight Ø1", parallel key 1/4"x1/4"x1 1/4" BS246
SH	Verzahnt Ø25,32 BS2059 (SAE 6 B) Splined Ø25,32, BS2059 (SAE 6 B)
SA	Verzahnt Ø24,5 B25x22 DIN5482 Splined Ø24,5 B25x22 DIN5482
K	Konisch 1:10, Ø28,56, Passfeder B5x5x14 DIN6885 Tapered 1:10, Ø28,56, parallel key B5x5x14 DIN6885

4.	Anschlüsse Drain ports
frei omit	BSPP (ISO295)
M	Metrisch (ISO262) Metric (ISO 262)

5.	Sonderausführungen Special features
LL	Geringeres Lecköl Low Leakage
FR	Leichtlaufausführung Free running
R	Drehrichtung umgedreht Reverse rotation
P	Lackiert (Farbe auf Anfrage) Paint (colour on request)
PC	Korrosionsschutzfarbe (Farbe auf Anfrage) Corrosion protected paint (colour on request)
PS	Speziallackierung (Anschlussflächen blank / Farbe auf Anfrage) Paint (non painted feeding surfaces / colour on request)
PCS	Korrosionsschutzfarbe Spezial (Anschlussflächen blank / Farbe auf Anfrage) Corrosion prot. paint special (non painted feeding surfaces / colour on request)

6.	Design Serie Design series
frei omit	Betriebspezifisch Factory specified

1. MONTAGEFLANSCH

1. MOUNTING FLANGE

Standard: Ovalflansch, 2 Befestigungslöcher
 Standard: Oval mount, 2 holes

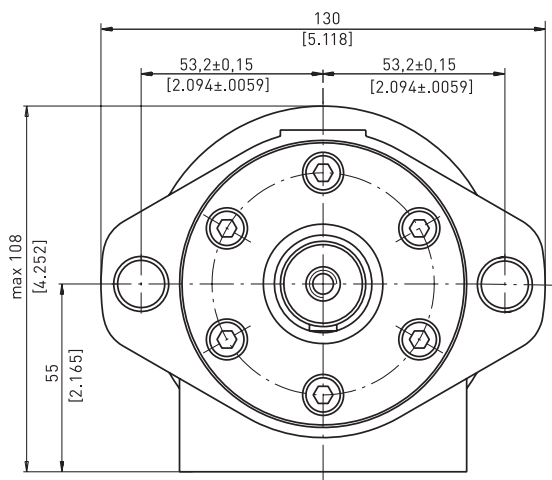

Option Q: Quadratflansch, 4 Gewindebohrungen
 Option Q: Square mount, 4 bolts

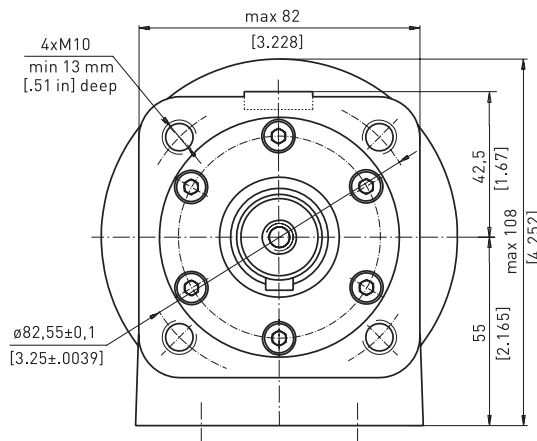

3. ABTRIEBSWELLE

3. SHAFT

Option C: Zylindrisch Ø25 mm
 Option C: Straight Ø 25 mm

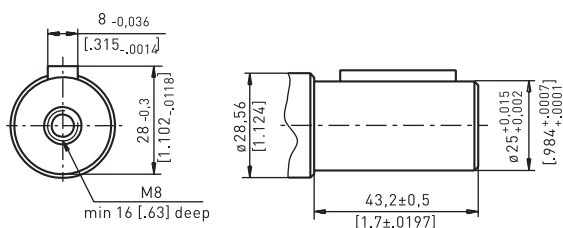

Option CO: Zylindrisch Ø1"
 Option CO: Straight Ø1"

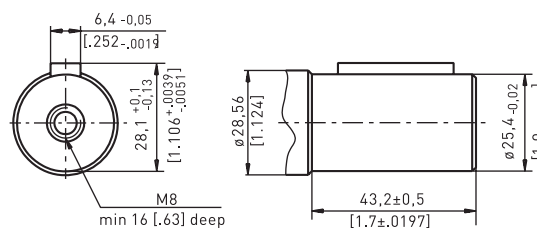

Option SH: Verzahnt SAE 6 B
 Option SH: Splined SAE 6 B

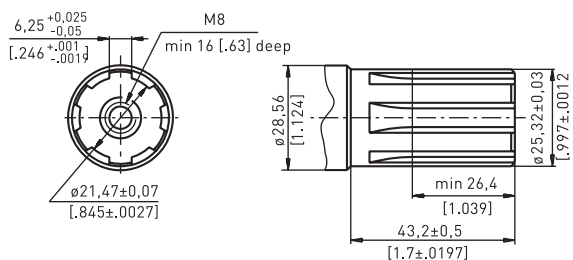

Option SA: Verzahnt B25x22h9
 Option SA: Splined B25x22h9

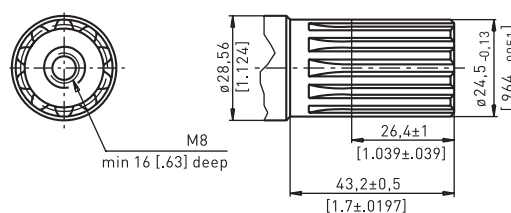

Option K: Konisch 1:10, Ø28,56 mm
 Option K: Tapered 1:10, Ø28,56 mm

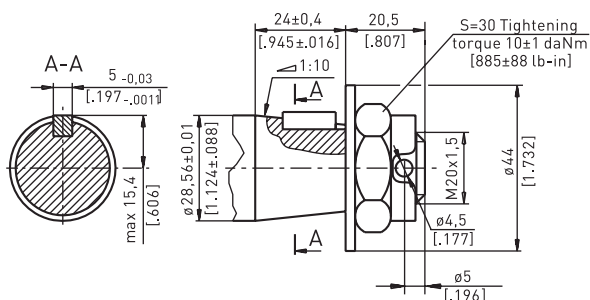

Zulässige Drehmomentabgabe
 Permissible output torque

Zulässige Drehmomentabgabe je nach Wellentyp Permissible output torque based on shaft type daNm [lb-in]				
C	CO	SH	SA	K
34 [3010]	34 [3010]	40 [3540]	40 [3540]	40 [3540]



EINBAUMAß DIMENSION

Ovalflansch Oval mount

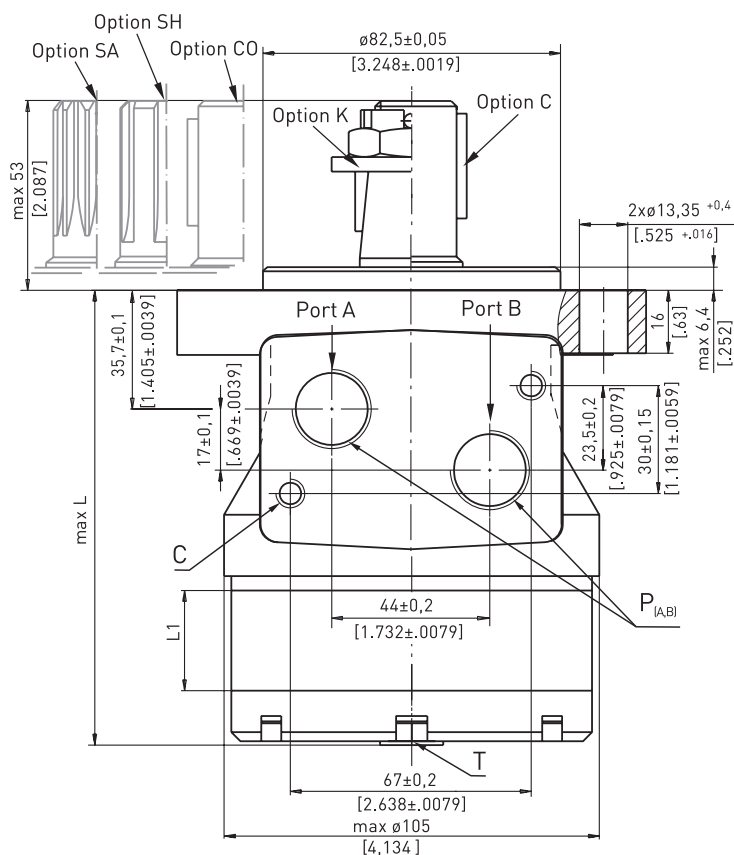

Quadratflansch Square mount

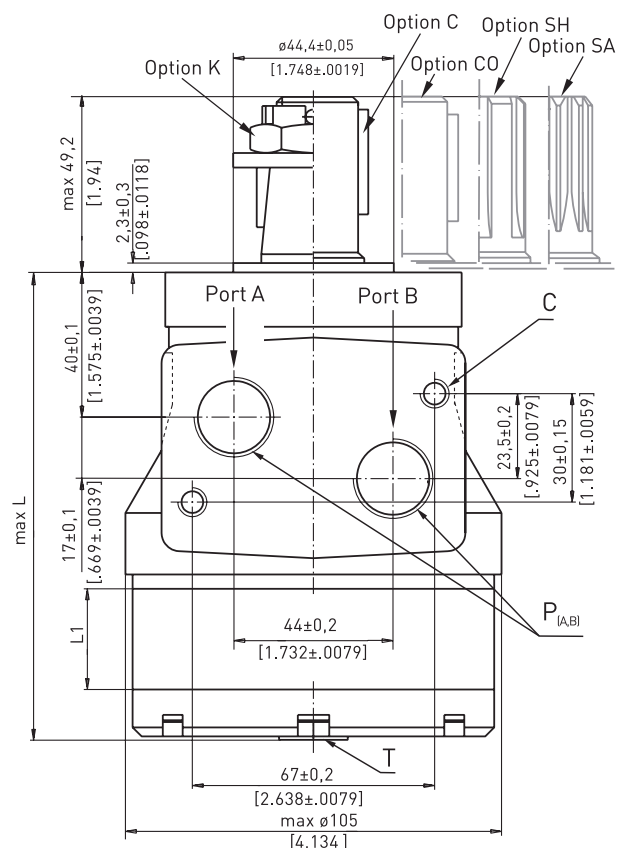

C: 4xM8 - 13mm [.51 in] tief deep
P (A,B): 2xG1/2 oder 2xM22x1,5 - 15mm [.59 in] tief deep
T: G1/4 oder M14x1,5 - 8,5 mm [.47 in] tief deep

Typ Type	L, mm [in]	Typ Type	L, mm [in]	L ₁ , mm [in]
EPRM-K 50	109,5 [4.31]	EPRM-K-Q 50	113,8 [4.48]	9,0 [.35]
EPRM-K 80	114,5 [4.51]	EPRM-K-Q 80	118,8 [4.68]	14,0 [.55]
EPRM-K 100	118,0 [4.65]	EPRM-K-Q 100	122,3 [4.82]	17,4 [.69]
EPRM-K 125	122,5 [4.82]	EPRM-K-Q 125	126,8 [4.99]	21,8 [.86]
EPRM-K 160	128,5 [5.06]	EPRM-K-Q 160	132,8 [5.23]	27,8 [1.09]
EPRM-K 200	135,5 [5.33]	EPRM-K-Q 200	139,8 [5.50]	34,8 [1.37]
EPRM-K 250	144,0 [5.67]	EPRM-K-Q 250	148,3 [5.84]	43,5 [1.71]
EPRM-K 315	155,5 [6.12]	EPRM-K-Q 315	159,8 [6.29]	54,8 [2.16]
EPRM-K 400	170,0 [6.69]	EPRM-K-Q 400	174,3 [6.86]	69,4 [2.73]

Standarddrehung
mit Blick auf Abtriebswelle
Druck auf Anschluss A - rechtsdrehend
Druck auf Anschluss B - linksdrehend

Reversierdrehung (5. - Option R)
mit Blick auf Abtriebswelle
Druck auf Anschluss A - linksdrehend
Druck auf Anschluss B - rechtsdrehend

Standard rotation
Viewed from shaft end
Port A pressurised- right running
Port B pressurised- left running

Reverse rotation (5. - Option R)
Viewed from shaft end
Port A pressurised- left running
Port B pressurised- right running

5. SONDERAUSFÜHRUNGEN

5. SPECIAL FEATURES

Option LL: Geringeres Lecköl Option LL: Low leakage

Die Hydraulikmotoren der LL Reihe sind für den Einsatz im ganzen Anwendungsbereich (Druckabfall und Drehzahl) entworfen. Sie haben jedoch erheblich geringere Verluste in den Verdrängungsräumen. Diese Motoren sind geeignet für hydraulische Systeme bei denen die Motoren in Reihe geschaltet sind und geringe Leckölverluste gefordert sind.

LL series hydraulic motors are designed to operate at the whole standard range of working conditions (pressure drop and frequency of rotation), but with considerable decreased volumetric losses in the drain ports. These motors are suitable for hydraulic system with series-connected motors with demands for low leakage.

Option FR: Leichtlaufausführung Option FR: Free running

FR Motoren haben größere Abstände zwischen den rotierenden Teilen im Planetensatz. Dadurch lässt sich die Abtriebswelle mit weniger mechanischem Widerstand drehen. Der größere Abstand verbessert auch die Schmierung der Abnutzungsflächen im Planetensatz. Weitere Vorteile ist eine längere Lebensdauer bei hohen Drehzahlen (größer 300 U/min) und geringem Druckabfall. Der volumetrische Wirkungsgrad kann bei diesen Motoren etwas geringer ausfallen.

FR motors are with increased clearance at all friction parts, allowing the shaft to rotate more freely with less mechanical drag. The increased clearance also improves lubrication of the wear surfaces of gear set and friction parts. Additional advantages of FR versions are prolonging of the life of the hydraulic motors at high speeds, as well as the possibility to use them in systems with wide variation of loading. FR series motors are designed to operate with high speed (over than 300 RPM) and low pressure drop. Volumetric efficiency may be reduced slightly.

WEITERE TECHNISCHE INFORMATIONEN

FURTHER TECHNICAL INFORMATION

Angaben zu Wellenbelastungen, Wellendichtungsdrücken und Leistungsdiagramme entnehmen Sie bitte unserem Katalog EPRM (ab Seite 1-5-11).

For informations about permissible shaft loads, permissible shaft seal pressure and function diagrams, please check our EPRM-catalogue (incipient from page (1-5-11)).