

# PLANETENMOTOR XMR

## ORBITAL MOTOR XMR

### ANWENDUNG

- o Förderbänder
- o Metallbearbeitungsmaschinen
- o Fördertechnik für Roboter
- o Landmaschinen
- o Nahrungsmittelindustrie
- o Rasenmäher
- o u.a.

### APPLICATION

- o Conveyors
- o Metal working machines
- o Feeding mechanism of robots and maipulators
- o Agricultural machines
- o Food industries
- o Grass cutting machines
- o etc.

### BAUWEISE UND AUSFÜHRUNGEN

- o Modell: Längsschieberventil, Planetenrollersatz
- o Ovalflansch
- o Anschlüsse: Seitlich, BSPP Gewinde
- o Wellen: Zylindrisch oder verzahnt

### CONSTRUCTION AND OPTIONS

- o Model: Spool valve, roll-gerotor
- o Mounting: Oval flange
- o Ports: Side ports, BSPP threaded ports
- o Shafts: Straight or splined

## ÜBERSICHT OVERVIEW

Max. Schluckvolumen	Max. Displacement	cm <sup>3</sup> /U	ccm/rev	[in <sup>3</sup> /rev]	397,0 [24.22]
Max. Drehzahl	Max. Speed	U/min	rpm		970
Max. Drehmoment	Max. Torque	daNm		[in/lb]	42,5 [3761]
Max. Leistungsabgabe	Max. Output	kW		[HP]	14,2 [19.04]
Max. Druckgefälle	Max. Pressure drop	bar		[PSI]	165 [2393]
Max. Ölstrom	Max. Oil flow	l/min	lpm	[GPM]	75 [19.8]
Min. Drehzahl	Min. Speed	U/min	rpm		10
Hydrauliköl	Pressure fluid				HLP (DIN 51524) oder or HM (ISO 6743/4)
Öltemperatur	Temperature range	° C		[° F]	-40 ÷ 140 [-40 ÷ 284]
Optimalviskosität	Optimal viscosity range	mm <sup>2</sup> /s		[SUS]	20 ÷ 75 [98 ÷ 347]
Filtrierung	Filtration				ISO code 20/16 (min. empfohlene Filtrierung recommended filtration 25 µm)

## ÖLSTROM LECKÖLLEITUNG OIL FLOW DRAIN LINE

Druckgefälle Pressure drop bar [PSI]	Viskosität Viscosity mm <sup>2</sup> /s [SUS]	Ölstrom Oilflow l/min lpm [GPM]
100 [1450]	20 [98]	2,5 [.660]
	35 [164]	1,8 [.476]
140 [2030]	20 [98]	3,5 [.925]
	35 [164]	2,8 [.740]

## DRUCKVERLUST PRESSURE LOSSES

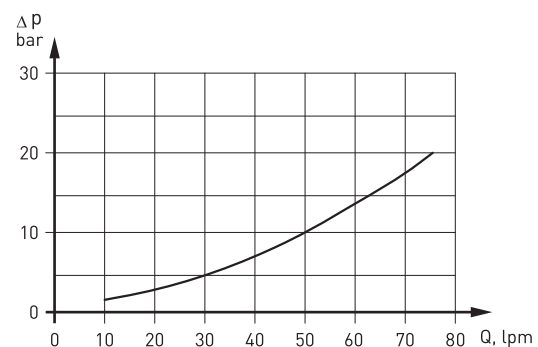

# TECHNISCHE DATEN

## TECHNICAL DATA

Typ Type		XMR 50	XMR 80	XMR 100	XMR 125	XMR 160	XMR 200	XMR 250	XMR 315	XMR 400
Schluckvolumen Displacement	cm <sup>3</sup> /U ccm/rev [in <sup>3</sup> /rev]	51,5 [3.14]	80,3 [4.90]	99,8 [6.09]	125,7 [7.67]	159,6 [9.74]	198,0 [12.10]	250,1 [15.26]	315,7 [19.30]	397,0 [24.22]
Max. Drehzahl Max. Speed U/min RPM	Dauerbetrieb Continuous working	776	747	601	477	376	300	240	190	151
	Intermittierend* Intermittent*	970	934	752	597	470	375	300	238	189
Max. Drehmoment Max. Torque daNm [lb-in]	Dauerbetrieb Continuous working	10,0 [885]	15,8 [1398]	19,6 [1734]	24,7 [2186]	31,3 [2770]	30,8 [2726]	31,5 [2787]	33,2 [2938]	33,4 [2956]
	Intermittierend* Intermittent*	11,4 [1008]	17,7 [1566]	22,0 [1947]	27,7 [2451]	35,2 [3115]	34,7 [3071]	41,8 [3699]	40,1 [3549]	42,5 [3761]
	Spitze** Peak**	12,3 [1088]	19,0 [1681]	23,5 [2079]	30,0 [2655]	37,5 [3319]	35,8 [3168]	42,0 [3717]	48,8 [4319]	47,4 [4195]
Max. Leistungsabgabe Max. Output kW [HP]	Dauerbetrieb Continuous working	7,0 [9.3]	10,5 [14.0]	10,8 [14.4]	11,0 [14.7]	10,2 [13.6]	7,5 [10.0]	7,1 [9.5]	5,9 [7.9]	4,2 [5.6]
	Intermittierend* Intermittent*	9,0 [12.0]	14,2 [19.0]	12,5 [16.7]	12,2 [16.3]	12,2 [16.3]	9,0 [12.0]	10,0 [13.4]	8,2 [10.9]	6,0 [8.0]
Max. Druckgefälle Max. Pressure drop bar [PSI]	Dauerbetrieb Continuous working	140 [2030]	140 [2030]	140 [2030]	140 [2030]	140 [2030]	105 [1523]	90 [1305]	75 [1088]	60 [870]
	Intermittierend* Intermittent*	165 [2393]	165 [2393]	165 [2393]	165 [2393]	165 [2393]	130 [1885]	125 [1812]	95 [1378]	80 [1160]
	Spitze** Peak**	185 [2683]	185 [2683]	185 [2683]	185 [2683]	185 [2683]	150 [2175]	140 [2030]	130 [1885]	100 [1450]
Max. Ölstrom Max. Oil flow l/min lpm [GPM]	Dauerbetrieb Continuous working	40 [10.5]	60 [15.9]	60 [15.9]	60 [15.9]	60 [15.9]	60 [15.9]	60 [15.9]	60 [15.9]	60 [15.9]
	Intermittierend* Intermittent*	50 [13.2]	75 [19.8]	75 [19.8]	75 [19.8]	75 [19.8]	75 [19.8]	75 [19.8]	75 [19.8]	75 [19.8]
Max. Eingangsdruck Max. Inlet pressure bar [PSI]	Dauerbetrieb Continuous working	165 [2393]	165 [2393]	165 [2393]	165 [2393]	165 [2393]	165 [2393]	165 [2393]	165 [2393]	165 [2393]
	Intermittierend* Intermittent*	185 [2683]	185 [2683]	185 [2683]	185 [2683]	185 [2683]	185 [2683]	185 [2683]	185 [2683]	185 [2683]
	Spitze** Peak**	200 [2900]	200 [2900]	200 [2900]	200 [2900]	200 [2900]	200 [2900]	200 [2900]	200 [2900]	200 [2900]
Max. Rücklaufdruck mit Leckölleitung Max. Return pressure with drain line bar [PSI]	Dauerbetrieb Continuous working	165 [2393]	165 [2393]	165 [2393]	165 [2393]	165 [2393]	165 [2393]	165 [2393]	165 [2393]	165 [2393]
	Intermittierend* Intermittent*	185 [2683]	185 [2683]	185 [2683]	185 [2683]	185 [2683]	185 [2683]	185 [2683]	185 [2683]	185 [2683]
	Spitze** Peak**	200 [2900]	185 [2683]	185 [2683]	185 [2683]	185 [2683]	185 [2683]	185 [2683]	185 [2683]	185 [2683]
Max. Anlaufdruck mit unbelasteter Welle Max. starting pressure with unloaded shaft	bar [PSI]	10 [145]	10 [145]	10 [145]	10 [145]	10 [145]	7 [101]	7 [101]	7 [101]	6 [87]
Min. Anlaufmoment bei max. Druckgefälle Min. starting torque at max. pressure drop	daNm [lb-in]	8,1 [716]	12,6 [1115]	15,6 [1380]	19,7 [1741]	25,0 [1717]	24,6 [2177]	25,2 [2230]	26,5 [2345]	26,7 [2363]
Min. Drehzahl*** Speed***	U/min RPM	10	10	10	10	10	10	10	10	10

- \* Intermittierend: Betrieb max. 10% pro Minute
- \*\* Spitze: max. 1% pro Minute
- \*\*\* Für Drehzahlen kleiner der min. Drehzahl sprechen Sie uns bitte an.
- Intermittierende Druckgefälle und Ölströme dürfen nicht gleichzeitig erreicht werden.
- Minimale Viskosität 13 mm<sup>2</sup>/s [70 SUS] bei 50 °C [122 °F]
- Maximale Öltemperatur während des Betriebs 82 °C [180 °F]
- Die Lebensdauer der Motoren kann erhöht werden, wenn die Antriebswelle 10-15 Minuten vor voller Belastung frei läuft.

- \* Intermittent: Working max. 10% per minute
- \*\* Peak: max. 1% per minute
- \*\*\* For speeds lower than given, please consult us.
- Int. speed and pressure should not occur simultaneously.
- Recommended min. oil viscosity 13 mm<sup>2</sup>/s [70 SUS] at 50 °C [122 °F]
- Recommended max. system operating temperature is 82 °C [180 °F]
- To assure optimum motor life fill with fluid prior to loading and run at moderate load and speed for 10-15 minutes.

# BESTELLCODE ORDER CODE

XMR	1	2	3	4
-----	---	---	---	---

1.	Schluckvolumen Displacement
50	49,5 cm <sup>3</sup> /U ccm/rev. [3.02 in <sup>3</sup> /rev]
80	79,2 cm <sup>3</sup> /U ccm/rev. [4.83 in <sup>3</sup> /rev]
100	99,0 cm <sup>3</sup> /U ccm/rev. [6.04 in <sup>3</sup> /rev]
125	123,8 cm <sup>3</sup> /U ccm/rev. [7.55 in <sup>3</sup> /rev]
160	158,4 cm <sup>3</sup> /U ccm/rev. [9.66 in <sup>3</sup> /rev]
200	198,0 cm <sup>3</sup> /U ccm/rev. [12.10 in <sup>3</sup> /rev]
250	247,5 cm <sup>3</sup> /U ccm/rev. [15.10 in <sup>3</sup> /rev]
315	316,8 cm <sup>3</sup> /U ccm/rev. [19.30 in <sup>3</sup> /rev]
400	396,0 cm <sup>3</sup> /U ccm/rev. [24.16 in <sup>3</sup> /rev]

2.	Abtriebswelle (Zul. Momentabgabe darf nicht überschritten werden) Shaft (Permissible output torque should not be exceeded)
C	Zylindrisch Ø25, Passfeder 8x7x32 DIN6885 Straight Ø25, parallel key 8x7x32 DIN6885
CO	Zylindrisch Ø1", Passfeder 1/4"x1/4"x1 1/4" BS246 Straight Ø1", parallel key 1/4"x1/4"x1 1/4" BS246
SH	Verzahnt Ø25,32 BS2059 (SAE 6 B) Splined Ø25,32, BS2059 (SAE 6 B)

3.	Sonderausführungen Special features
P	Lackiert (Farbe auf Anfrage) Paint (colour on request)
PC	Korrosionsschutzfarbe (Farbe auf Anfrage) Corrosion protected paint (colour on request)
PS	Speziallackierung (Anschlussflächen blank / Farbe auf Anfrage) Paint (non painted feeding surfaces / colour on request)
PCS	Korrosionsschutzfarbe Spezial (Anschlussflächen blank / Farbe auf Anfrage) Corrosion prot. paint special (non painted feeding surfaces / on request)

4.	Design Serie Design series
frei omit	Betriebsspezifisch Factory specified

## 2. ABTRIEBSWELLE 2. SHAFT

Option C: Zylindrisch Ø25 mm  
Option C: Straight Ø 25 mm

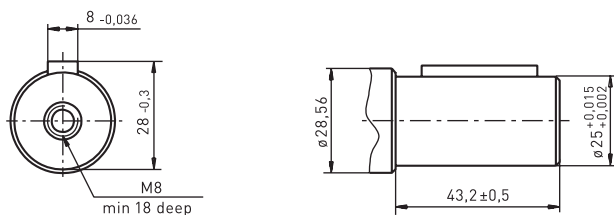

Option CO: Zylindrisch Ø1"  
Option CO: Straight Ø1"

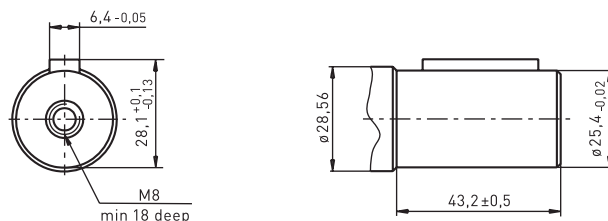

Option SH: Verzahnt SAE 6 B  
Option SH: Splined SAE 6 B

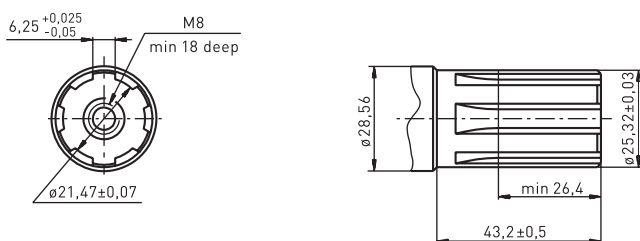

Zulässige Drehmomentabgabe  
Permissible output torque

Zulässige Drehmomentabgabe je nach Wellentyp Permissible output torque based on shaft type daNm [lb-in]		
C	CO	SH
34 [3010]	34 [3010]	40 [3540]

# EINBAUMAß DIMENSION

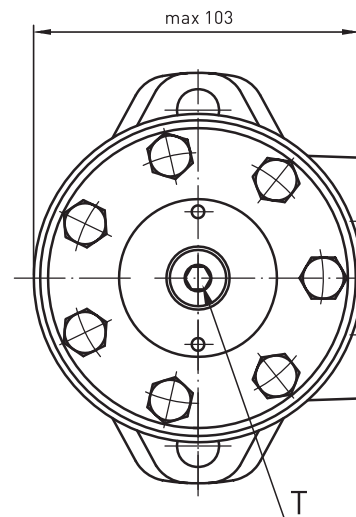
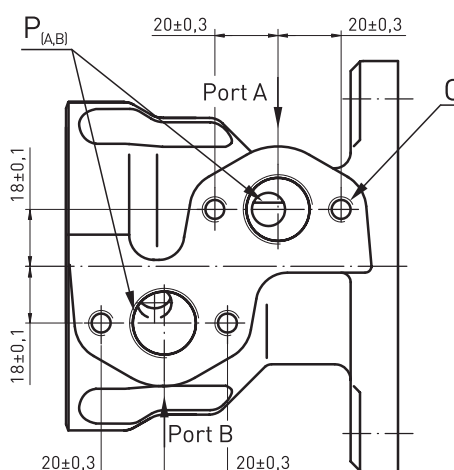
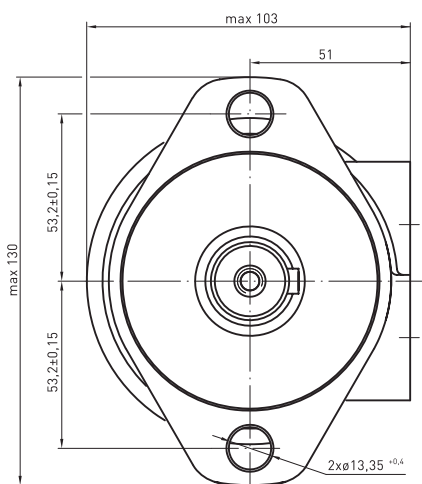
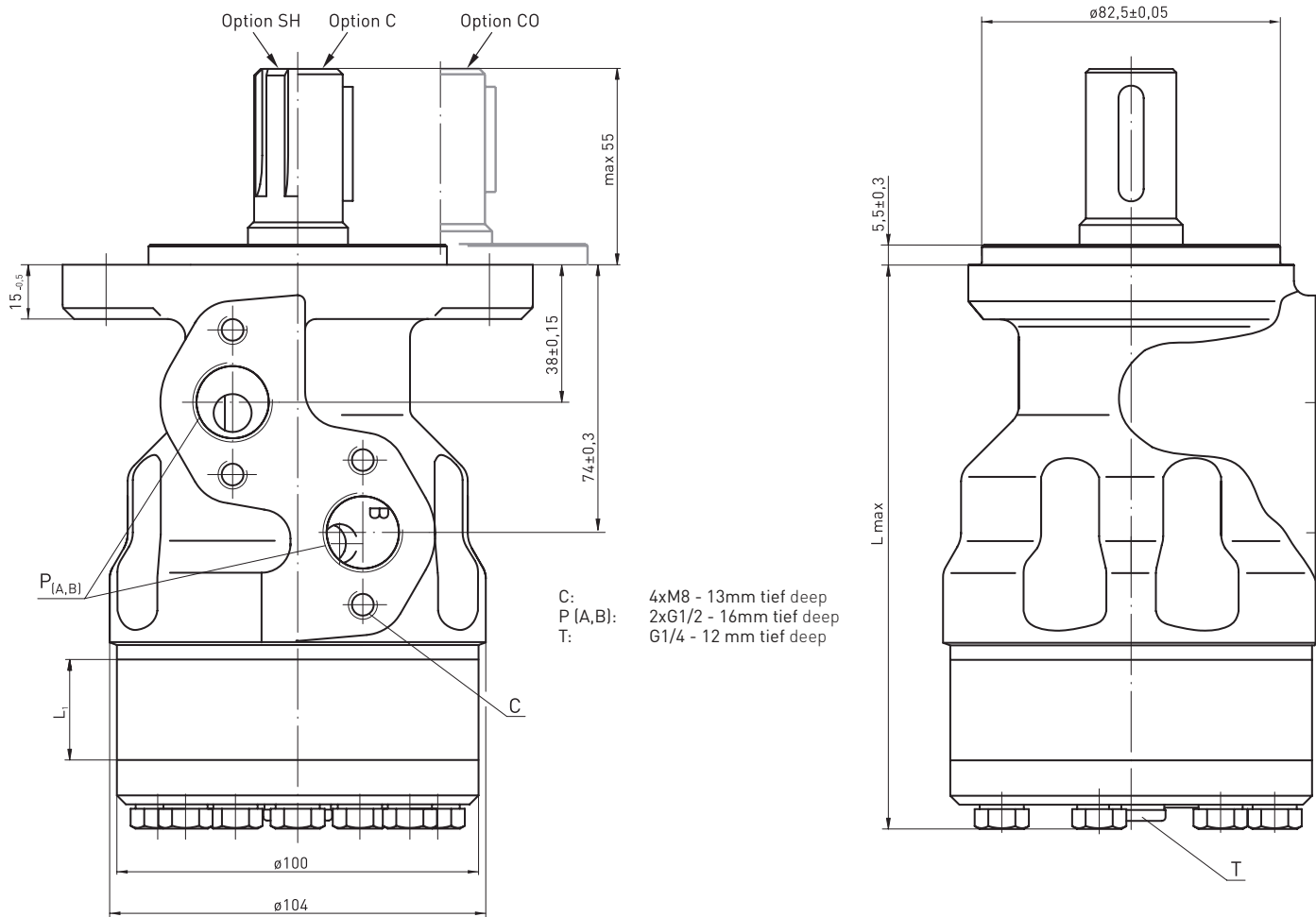

Typ Type	L <sub>max</sub> , mm	L <sub>1</sub> , mm
XMR 50	138,0	9,0
XMR 80	143,0	14,0
XMR 100	146,0	17,4
XMR 125	150,5	21,8
XMR 160	156,5	27,8
XMR 200	163,5	34,8
XMR 250	172,0	43,5
XMR 315	183,0	54,8
XMR 400	198,0	69,4

Standarddrehung  
mit Blick auf Abtriebswelle  
Druck auf Anschluss A - rechtsdrehend  
Druck auf Anschluss B - linksdrehend

Reversierdrehung  
mit Blick auf Abtriebswelle  
Druck auf Anschluss A - linksdrehend  
Druck auf Anschluss B - rechtsdrehend

Standard rotation  
Viewed from shaft end  
Port A pressurised- right running  
Port B pressurised- left running

Reverse rotation  
Viewed from shaft end  
Port A pressurised- left running  
Port B pressurised- right running

## WEITERE TECHNISCHE INFORMATIONEN FURTHER TECHNICAL INFORMATION

### Zulässige Wellenbelastung XPM Permissible shaft load XPM

Die zulässige radiale Wellenbelastung  $P_{rad}$  hängt ab von den Drehzahlen (n) und Abstand (L) zwischen dem Angriffspunkt der Last und dem Befestigungsflansch.

The permissible radial shaft load  $P_{rad}$  depends on the speed (n) and the distance (L) from the point of load to the mounting flange and shaft version.

$$\text{Radial Shaft Load } P_{rad} = \frac{800}{\text{RPM}} \times \frac{15000}{95 + L}, \text{ daN}$$

RPM > 200  
L < 55 mm

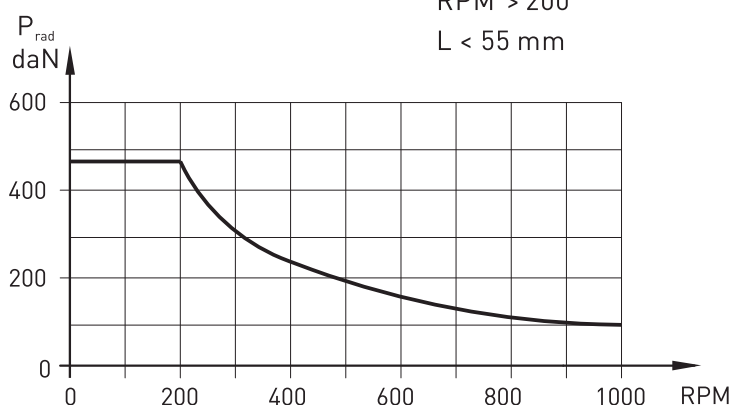

$P_{a\max} = 150 \text{ daN}$

$P_{a\max} = 200 \text{ daN}$

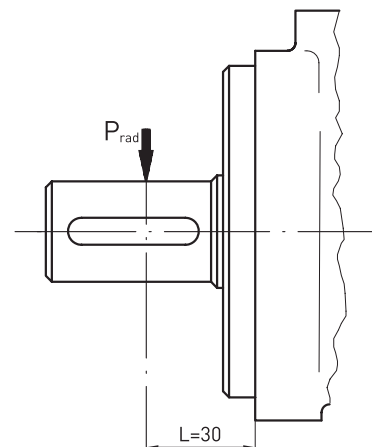

### Max. Druck auf die Wellendichtung Max. permissible shaft seal pressure

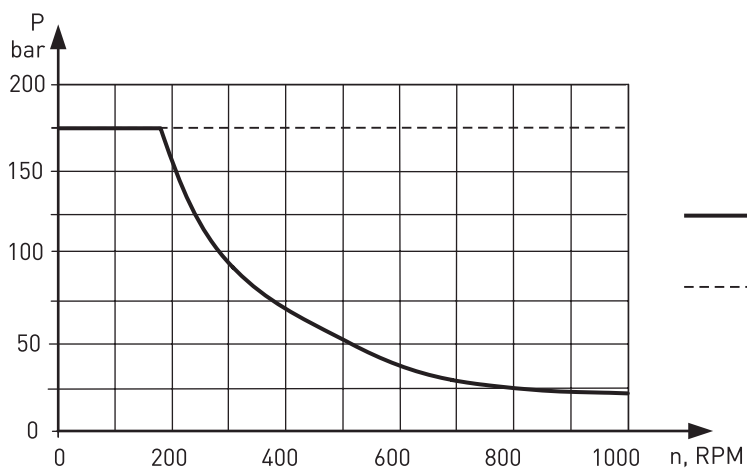

— Dauerbetrieb  
Continuous Operation

- - - - - Intermittierender Betrieb  
Intermittent Operation